

E-TENDER FOR

Name of Work: Operation of Trash Rack Cleaning Machine (TRCM) installed in the intake channel of Pumping station Pise for the period of Six months

Bid Document No. :-

Website: www.mahatenders.gov.in

Office of: Executive Engineer (Mech. & Elect.) Pise
At Pise, Post Amne
Tal.Bhiwandi
Dist. Thane 421 302
Contact No. 9967872450

“INDEX”

SECTION	DESCRIPTION	PG-NO.
1	E-TENDER NOTICE	4-8
2	ELIGIBILITY CRITERIA	9-11
3	DISCLAIMER	12-14
4	INTRODUCTION	15-17
5	E-TENDER ONLINE SUBMISSION PROCESS	18-21
6	INSTRUCTIONS TO APPLICANTS	22-40
7	SCOPE OF WORK & SELECTION OF MATERIAL	41-42
8	BILL OF QUANTITIES	43-44
9	GENERAL CONDITIONS OF CONTRACT	45-84
10	SPECIFICATIONS	85-91
11	FRAUD AND CORRUPT PRACTICES	92-95
12	PRE-BID MEETING	96-97
13	LIST OF APPROVED BANKS	98-100
14	APPENDIX	101-116

SECTION - 1
E-TENDER NOTICE

BRIHANMUMBAI MUNICIPAL CORPORATION

E-TENDER NOTICE

Name of Work: Operation of Trash Rack Cleaning Machine (TRCM)
installed in the intake channel of Pumping station Pise for
the period of Six months

The BRIHANMUMBAI MUNICIPAL CORPORATION (BMC) invites e-tender on "Item rate" basis in Packet 'A','B' and 'C' system for the aforementioned work from the tenderers which are reputed, multidisciplinary engineering organizations i.e. eminent firm, Proprietary/ Partnership Firms/ Private Limited Companies/ Public Limited Companies/ Companies who are vendors registered with the Brihanmumbai Municipal Corporation, (BMC) in **Class "B" as per new registration** and from the tenderers equivalent and superior classes registered in Central or State Government/Semi Govt. Organization/Central or State Public Sector Undertakings, will be allowed subject to condition that, the tenderers who are not registered with MCGM will have to apply for registering their firm within three months time period from the award of contract, otherwise their Bid Security i.e. E.M.D. (Earnest Money Deposit) will be forfeited/recovered and an amount equal to Registration Fee of respective class will be recovered as penalty.

Bidding Process will comprise of THREE stages.

The application form can be downloaded from e-procurement system of Government of Maharashtra (Mahatenders) (<http://mahatenders.gov.in>). The applicants not registered with BMC are mandated to get registered (Vendor Registration) with BMC for e-tendering process & obtain login credentials to participate in the online bidding process.(The application form can be downloaded from BMC's portal (Mahatenders) (<http://mahatenders.gov.in>) on payment of **Rs.1000+18% GST**.)

- i) To download the application form, for those applicants not having vendor registration, need to apply first for vendor registration at the office of Account Officer (FAR), 3rd floor, Municipal Headquarter. **(Note- Online vendor registration is available on BMC's portal <http://portal.mcgm.gov.in>)**
- ii) Followed by SRM login ID and password to be obtained from Central Purchase Department (CPD), Office at Byculla, Bakariadda, Mumbai
- iii) For e-Tendering registration, enrollment for digital signature certificates and user manual, please refer to respective links provided in 'Tenders' tab. Vendors can get digital signature from any one of the Certifying Authorities (CA's) licensed by controller of certifying authorities namely, Safes crypt, IDRBT, National informatics center, TCS, CUSTOMS, MTNL, GNFC and e- Mudhra CA.

Tender No.	Name and location of work	Contract period	Estimated Cost of Project
	Operation of Trash Rack Cleaning Machine (TRCM) installed in the intake channel of Pumping station Pise for the period of Six months	Six Months n (Including Monsoon)	Not Applicable being item rate tender.

While submitting duly filled tender document on mahatender, bidder needs to pay total **EMD amounting to Rs.10,100/-** online through <https://mahatenders.gov.in>. EMD is refundable in accordance to the relevant clause of bid document, except in the case of the selected Bidder who's Bid Security/EMD shall be retained. The Bidders will have to provide Earnest Money Deposit through the payment gateways while submitting the bids. The Bid shall be summarily rejected if it is not accompanied by the Earnest Money Deposit. The tender is available on e-Procurement System of Government of Maharashtra (Mahatenders) <https://mahatenders.gov.in>. as mentioned in the Header Data of the tender.

As per THREE Packet systems, the document for Packet A & B is to be uploaded by the bidder in vendors' document online in Packet A, B. Packet A, B & C shall be opened on dates as mentioned in header data. All the responsive and eligible bidders if they so wish can be present at the time of opening of bids, in the office of Executive Engineer (Mech & Elec.) Pise. The Packet C shall be opened if bids submission in Packet A & B satisfies/includes all the requirements and same are found acceptable to the Authority.

The Municipal Commissioner reserves the right to reject all or any of the e- tender(s) without assigning any reasons at any stage.

The dates and time for submission and opening the bids are as shown in the Header Data. If there are any changes in the dates the same will be displayed on e-procurement system of Government of Maharashtra (Mahatenders) (<http://mahatenders.gov.in>)

The Applicants interested for the above referred works may contact the Dy. Hydraulic Engineer (Pise-Panjrapur Complex) at the following address on any working day during office hours.

Office of: Executive Engineer (Mech. & Elect.) Pise
At Pise, Post Amne
Tal.Bhiwandi
Dist. Thane 421 302
Contact No. 9967872450.
Email :- eamnepippc.he@mcm.gov.in

The applicants may wish to visit the site under reference located **at Pise, Post: Amne, Tal: Bhiwandi, Dist:Thane** and can collect the information of the present status from the department who have invited the bids.

BMC reserves the rights to accept any of the application or reject any or all the application received for above works, without assigning any reasons thereof. The information regarding above subject matter is available on e-procurement system of Government of Maharashtra (Mahatenders) (<http://mahatenders.gov.in>).

Bidders are also advised to refer “Bidders Manual Kit” available at <https://mahatenders.gov.in/nicgep/app?page=BiddersManualKit&service=page> for further details about the e-tendering process.

For any help, in the e-Tendering process, can be availed by dialing help-desk number 022- 22046934/22837339 from 11.30 AM to 5.00 PM on all working days . Email: support-eproc@nic.in

SPECIAL NOTE : TENDERERS ARE REQUESTED TO GO THROUGH THE e- TENDER GUIDELINES ON NIC PORTAL (<https://mahatenders.gov.in>). For registration, enrolment for digital signature certificate & user manual, pleaserefer to respective links provided in e-tendering tab. The vendors can get digital signature from any one of the Certifying Authorities (CA’s) licensed by the Controller of Certifying Authorities namely Safes crypt, IDRBT, National Informatics Centre, TCS, Customs, MTNL, GNFC and e- Mudhra.

Executive Engineer (M&E) Pise

Header Data	
Tender Document No.	2024_MCGM_1110963
Name of Organization	BRIHANMUMBAI MUNICIPAL CORPORATION
Subject	Operation of Trash Rack cleaning machine installed near Pumping station Pise for the period of one year.
Tender Fee	Rs.3894/- (Rs.3300/- + 18% GST).
Bid Security Deposit/ EMD	Rs.10,100/-
Date of issue and sale of tender	11.10.2024 from 11:00 Hrs
Last date & time for sale of tender	25.10.2024 upto 16:00 Hrs
Submission of Packet A, B & Packet C(Online) &(Receipt of Bid Security deposite)	25.10.2024 upto 16:00 Hrs
Pre-Bid Meeting	Not Applicable.
Opening of Packet A	29.10.2024 after 16:01Hrs
Opening of Packet B	29.10.2024 after 16:10 Hrs
Opening of Packet C	08.11.2024 after 15:00Hrs
Address for communication	Executive Engineer (Mech. & Elect.) Pise At Pise, Post Amne Tal.Bhiwandi Dist. Thane 421 302 Contact No. 9967872450. Email :- eemnemcgpise@gmail.com
Venue for opening of bid	On line in office of Ex.Engr. (M&E)Pise.
<p>Note :As per Circular no. CA/FRG/09 dtd. 04.10.2024, all the tenderers shall have to pay the tender fee with GST through online system on Government of Maharashtra Mahatender portal.</p>	

This tender document is not transferable.

The BMC reserves the rights to accept any of the application or reject any or all the application received for above subject without assigning any reason thereof.

Executive Engineer (M&E) Pise

SECTION - 2
ELIGIBILITY CRITERIA

For Regular, Routine and Maintenance Work

1.1 Technical Capacity:

The tenderer(s) in their own name should have satisfactorily executed the work of similar nature MCGM /Semi Govt. /Govt. & Public Sector Organizations during last seven (7) years ending last day of month previous to the one in which bids are invited as a prime Contractor (or as a nominated sub-Contractor, where the subcontract had involved similar nature of work as described in the scope of works in this bid document, provided further that all other qualification criteria are satisfied)

a) Three similar completed works of similar nature each costing minimum of

Rs.3.03 Lakhs OR

b) Two similar completed works of similar nature each costing minimum of

Rs.3.53 Lakhs OR

c) One completed work of similar nature of minimum of **Rs.5.05 Lakhs**

The value of executed works shall be brought to current costing level by enhancing the actual value of work at compound rate of 10 % per Annam, calculated from the date of completion to last date of receipt of applications for tenders. Tenderer shall upload documentary evidence for eligibility along with the tender.

1.2 Financial capacity:

Achieved an average annual financial turnover as certified by 'Chartered Accountant' equal to **Rs.3.03 Lakhs in last three (3) financial years** immediately preceding the Financial Year in which bids are invited. The value of executed works shall be brought to current costing level by enhancing the actual value of work at compound rate of 10 % per annum; calculated from the date of completion to last date of receipt of applications for tenders.

Documentary evidence shall be submitted.

1.3 Similar Experience:

- For assessing the technical capacity of Regular, Routine & Maintenance works; the similar work shall mean SITC of Trash Rack cleaning Machine (TRCM)/ O & M of Trash cleaning machine or Pumping station of minimum 450MLD capacity.
- Past performance certificates, including the work order number and date, cost of the work, contract period, etc. shall be annexed by the bidder while submitting the offer.

1.4 • **Bid Capacity: (Not Applicable for this tender)**

~~• The bid capacity of the prospective bidders will be calculated as under:~~

~~• **Assessed Available Bid Capacity = (A* N* 2 - B)**~~

~~• Where,~~

~~• **A** = Maximum value of Civil Engineering works executed in any one year (year means Financial year) during **the last five years** (updated to the price level of the Financial year in which bids are received at a rate of 10% per year) taking into account the completed as well as works in progress.~~

~~• **N** = Number of years prescribed for completion of the Project/Works, **excluding monsoon period**, for which these bids are being invited. (E.g. 7 months = 7/12 year) For every intervening monsoon 0.33 shall be added to N.~~

~~• **B** = Value of existing commitments (only allotted works) on the last date of submission of bids as per bidding document and on going works to be completed during the period of completion of the Project/Works for which these bids are being invited.~~

~~• **Note:** The statement showing the value of existing commitments and on going works as well as the stipulated period of completion remaining for each of the works listed should be attached along with certificates duly signed by the Engineer in Charge, not below the rank of an Executive Engineer or equivalent.~~

~~• **Even though the bidders meet the above qualifying criteria, they are subject to be disqualified if they have:**~~

~~• made misleading or false representation in the forms, statements and attachments submitted in proof of the qualification requirements; and/or~~

~~• **Record for poor performancee such as abandoning the works, not properly completing the contract, inordinate delays in completion, litigation history, or financial failures etc.**~~

SECTION 3
DISCLAIMER

DISCLAIMER

The information contained in this e-tender document or provided to Applicant(s), whether verbally or in documentary or any other form, by or on behalf of the BRIHANMUMBAI MUNICIPAL CORPORATION (BMC), hereafter also referred as “The Authority “, or any of its employees or advisors, is provided to Applicant(s) on the terms and conditions set out in this e-tender and such other terms and conditions subject to which such information is provided.

This e-tender includes statements, which reflect various assumptions and assessments arrived at by the BRIHANMUMBAI MUNICIPAL CORPORATION (BMC) in relation to the Project. Such assumptions, assessments and statements do not purport to contain all the information that each Applicant may require. This e-tender may not be appropriate for all persons, and it is not possible for the BRIHANMUMBAI MUNICIPAL CORPORATION (BMC), its employees or advisors to consider the investment objectives, financial situation and particular needs of each party who reads or uses this e-tender. The assumptions, assessments, statements and information contained in this e-tender may not be complete, accurate, adequate or correct. Each Applicant should therefore, conduct its own investigations and analysis and should check the accuracy, adequacy, correctness, reliability and completeness of the assumptions, assessments, statements and information contained in this e-tender and obtain independent advice from appropriate sources.

Information provided in this e-tender to the Applicant(s) is on a wide range of matters, some of which may depend upon interpretation of law. The information given is not intended to be an exhaustive account of statutory requirements and should not be regarded as a complete or authoritative statement of law. The BRIHANMUMBAI MUNICIPAL CORPORATION (BMC) accepts no responsibility for the accuracy or otherwise for any interpretation or opinion on law expressed here.

The BRIHANMUMBAI MUNICIPAL CORPORATION (BMC) its employees and advisors make no representation or warranty and shall have no liability to any person, including any Applicant or Bidder, under any law, statute, rules or regulations or tort, principles of restitution or unjust enrichment or otherwise for any loss, damages, cost or expense which may arise from or be incurred or suffered on account of anything contained in this e-tender or otherwise, including the accuracy, adequacy, correctness, completeness or reliability of the e-tender and any assessment, assumption, statement or information contained therein or deemed to form part of this e-tender or arising in any way with pre-qualification of Applicants for participation in the Bidding Process. The BRIHANMUMBAI MUNICIPAL CORPORATION (BMC) also accepts no liability of any nature whether resulting from negligence or otherwise howsoever caused arising from reliance of any Applicant upon the statements contained in this e-tender.

The BRIHANMUMBAI MUNICIPAL CORPORATION (BMC) may, in its absolute discretion but without being under any obligation to do so, update, amend or supplement the information, assessment or assumptions contained in this e-tender.

The issue of this e-tender does not imply that the BRIHANMUMBAI MUNICIPAL CORPORATION (BMC) is bound to select and short-list pre-qualified Applications for Bid Stage or to appoint the selected Bidder or Concessionaire, as the case may be, for the Project and the BRIHANMUMBAI MUNICIPAL CORPORATION (BMC) reserves the right to reject all or any of the Applications or Bids without assigning any reasons whatsoever.

The Applicant shall bear all its costs associated with or relating to the preparation and submission of its Application including but not limited to preparation, copying, postage, delivery fees, expenses associated with any demonstrations or presentations which may be required by The BRIHANMUMBAI MUNICIPAL CORPORATION (BMC) or any other costs incurred in connection with or relating to its Application. All such costs and expenses will remain with the Applicant and the BRIHANMUMBAI MUNICIPAL CORPORATION (BMC) shall not be liable in any manner whatsoever for the same or for any other costs or other expenses incurred by an Applicant in preparation or submission of the Application, regardless of the conduct or outcome of the Bidding Process.

SECTION 4
INTRODUCTION

INTRODUCTION

1. Background:

The BRIHANMUMBAI MUNICIPAL CORPORATION (BMC) covers an area of 437.71 sq.kms. with a population of 1.24 Crores as per census of 2011. The metropolis accounts major portion of India's international trade and government's revenue, from being one of the foremost centers of education, science and technological research and advancement.

The Mumbai Metropolis has historic tradition of strong civic activism dedicated to the cause of a better life for all its citizens. And it's the BRIHANMUMBAI MUNICIPAL CORPORATION (BMC), hereafter called the "corporation", the primary agency responsible for urban governance in Greater Mumbai.

BMC (The Authority) is one of the largest local self-governments in the Asian Continent. In observance of historic traditions of strong civic activism, with the change in time and living conditions to match with the urbanization, BMC has mainly focused in providing almost all kinds of engineering services viz, Hydraulics, storm water drain, sewerage, water supply projects, roads, bridges, solid waste management, and environmental services. Beside this, the BMC is also providing dedicated services in various segments such as Health, Primary Education as well as the construction and maintenance of Public Markets and Slaughter Houses.

BMC is an organization having different departments, right from engineering depts. to health depts. Moreover we have other dept. like education, market, fire brigade dept., Octroi and other such departments where quite a good number of staff members are working.

Preamble:

Pise pumping station is located at the right bank of Bhatsa River". Seven Numbers of Vertical turbine pumps were installed and commissioned under each Stage i.e. Stage-I, II & III in the year 1979, 1986 & 1996 respectively. Since then these pumps are in continuous service.

Pise weir is constructed 48 Kms downstream of Bhatsa dam wherein the daily demand of water is stored and pumped by vertical Turbine Pumps to panjarapur for treatment. To restrict the entry of various types of vegetation, animal bodies etc weed screens are installed near pumping station.

In monsoon season, heavy material along with weeds & grass deeply submerged in the water gets accumulated on the weed screens. Due to this, the flow towards pump sump gets restricted and the water level drops by 2 to 3 metres in the pump sump than the water level in the weir, resulting in heavy vibrations and reduced flow. Hence these accumulated floating vegetation needs to be cleaned regularly.

Therefore, **MUHR** make Trash rack cleaning machine (TRCM) is installed at intake channel of Pise pumping station. The work of installation, testing and commissioning of the system was carried out by M/s. VIRGO SPECIALTIES in 2021 to remove floating vegetation & submerged vegetation accumulated on the weed screens at the depth of 10 meter.

The system comprises of Chasis, Base, and Boom etc. The operation of the TRCM is very important and critical as it directly affects the daily discharge and performance of the Pumping Station.

The contractor has to operate this machine and clean weed screens, remove floating vegetation nearby screen & dispose removed floating vegetation to the place suggested by BMC Engineers.

SECTION 5
E-TENDERING ONLINE SUBMISSION PROCESS

E-TENDERING ONLINE SUBMISSION PROCESS

1	Thee-Tendering process of BMC is enabled through NIC's Mahatender Portal https://mahatenders.gov.in/nicgep/app
2	All the tender notices including e-Tender notices will be published on NIC's Mahatender Portal https://mahatenders.gov.in/nicgep/app
3	All the information documents are published under the NIC's Mahatender portal.
4	All the interested vendors are required to be registered with NIC's Mahatender portal for e-Tendering process. Vendors not registered with NIC's Mahatender portal can apply online by clicking the link online registration section of NIC's Mahatender portal. "https://mahatenders.gov.in/nicgep/app?component=%24WebHomeBorder.%24WebRightMenu.%24DirectLink&page=Home&service=direct&session=T"
5	Manual offers sent by post/Fax or in person will not be accepted against e-tenders even if these are submitted on the Firm's letter head and received in time. All such manual offers shall be considered as invalid offers and shall be rejected summarily without any consideration
6	Please read the tender document carefully "Instructions and Articles of Agreement" for supply of general items. All documents that are required to be submitted as part of eligible & technical bid, need to be uploaded in the Packets provided for this purpose and commercial bid need to be filled online.
7	This document (Instructions to vendors) and the 'Articles of Agreement' document which are available in the tender document make part of all tender documents unless stated otherwise in the tender document
8	Affixing of digital signature for the bid document while submitting the bid, shall be deemed to mean acceptance of the terms and conditions contained in the tender document as well as confirmation of the bid/bids offered by the vendor which shall include acceptance of special Directions/ terms and conditions if any, incorporated
9	All the documents and data submitted by vendors online shall be digitally signed.

	The system will prompt for digital signature certificate. It is mandatory for the vendors willing to participate in tender process to procure digital signature certificate of class-2/ class-3 and Company Type.
10	Certifying authorities (CA) in India. However, for the convenience of the vendors, a team from one of the certifying authorities is made available to help them for obtaining digital Signature certificates. Interested vendors may approach help desk for details.
11	The browser settings required for digitally signing the uploaded documents are listed in the Link “Site Compatibility” available on Mahatender Portal
12	In order to participate in the tender process ,the registered vendors need to follow the steps given inthe section “Guidelines for hassle free Bid submission” and “Bidders Manual Kit-Open Source Software Link” available on Mahatender portal
a	Open the e-Tendering application by clicking the link available in on https://www.mahatenders.gov.in
b	Make the Browser Settings as per the guidance available in “Site Compatibility” section. Carry out the necessary settings and root certificates installation as mentioned in the document. Vendors to note that the computer user should have administrative rights to the computer to be able to work with e-Tendering application
c	Login to the application with your credentials and follow the instructions given in the document “User Manual for Vendors- Bidding Process” which is available in the “For Partners” section of Mahatender Portal.
d	As per Circular no. CA/FRG/10 dtd. 19.10.2023, all the tenderers shall have to pay the scrutiny fee with GST. It is to be paid at CFC center by obtaining challan from respective section before opening of packet C .
e	Pay EMD and other charges, where applicable, as per the instructions given in the Tender Notice and/or Tender Document.
f	Upload the administrative & technical bid documents. System will prompt for digital signature certificate while uploading the document.
g	Ensure that documents are uploaded properly by downloading them after uploading.
h	Submitting the commercial bid by filling in the values on the screen. All the inputs given on this screen need to be digitally signed.
i	The administrative, technical and commercial bids can be submitted only online on or before the due date and due time mentioned for submission of bids.

j	The bids can be modified till the end date and time for bid submission. However, if a new version of a document is to be uploaded, please ensure to delete the old version.
k	Ensure that bid is submitted by ensuring that the “status” of the bid in the initial bids listing screen is “Bid submitted”.
13	Vendors should ensure to submit their bids well in advance before the due date and due time. Vendors trying to submit the bid at last moment just before due date and due time and failing to do so due to system problems at their end, internet problems, User Id locking problems etc. shall note that no complaints in this regard will be entertained.
14	It is the responsibility of the vendors to maintain their computers, which are used for submitting their bids, free of viruses, all types of malware etc. by installing appropriate anti-virus software and regularly updating the same with virus free signatures etc. Vendors should scan all the documents before uploading the same.
15	The administrative, technical and commercial evaluation documents will be available for all the participating vendors after completion of the evaluation.
16	Additional information can be availed by referring to FAQs in the e-Procurement section of Mahatender portal.
17	For any help, in the e-Tendering process, can be availed by dialing help-desk number 022-24811275/76 (BMC IT Cell) from 10.30AM to 6.00PM on all working days of BMC.
	Email support- Working hours 10.00 AM to 6.00 PM (Monday to Friday) Tele Support- Working hours 10.00 AM to 6.00 PM (Monday to Friday) NOTE- Support will not be available on Public Holiday & Saturday-Sunday

SPECIAL NOTE:

In order to participate in the tender process , the registered vendors need to follow the steps given in the section “ Guidelines for hassle free Bid submission” and “Bidders Manual Kit - Open Source Software Link” available on Mahatender portal

For registration, enrolment for digital signature certificate & user manual, please refer to respective links provided in e-tendering tab. The vendors can get digital signature from anyone of the Certifying Authorities (CA’s) licensed by the Controller of Certifying Authorities namely Safes crypt, IDRBT, National Informatics Centre, TCS, Customs, MTNL, GNFC and e-Mudhra.

SECTION 6
INSTRUCTIONS TO
APPLICANTS

INSTRUCTIONS TO APPLICANTS

□ A) Scope of Application

The Authority wishes to receive Applications for Qualification in order to SELECT experienced and capable Applicants for the Bid Stage.

B) Eligibility of Applicants

The BRIHANMUMBAI MUNICIPAL CORPORATION (BMC) invites e-tender on “Item rate” basis in Packet ‘A’, ‘B’ and ‘C’ system for the aforementioned work from the tenderers which are reputed, multidisciplinary engineering organizations i.e. eminent firm, Proprietary/ Partnership Firms/ Private Limited Companies/ Public Limited Companies/ Companies who are vendors registered with the Brihanmumbai Municipal Corporation, (BMC) in **Class “B” as per new registration** and from the tenderers equivalent and superior classes registered in Central or State Government/Semi Govt. Organization/Central or State Public Sector Undertakings, will be allowed subject to condition that, the tenderers who are not registered with MCGM will have to apply for registering their firm within three months time period from the award of contract, otherwise their Bid Security i.e. E.M.D. (Earnest Money Deposit) will be forfeited/recovered and an amount equal to Registration Fee of respective class will be recovered as penalty.

To be eligible, an Applicant shall fulfill the following conditions of eligibility criteria:

1. For Regular, Routine and Maintenance Work.

1.1 Technical Capacity:

The tenderer(s) in their own name should have satisfactorily executed the work of similar nature MCGM /Semi Govt. /Govt. & Public Sector Organizations during last seven (7) years ending last day of month previous to the one in which bids are invited as a prime Contractor (or as a nominated sub-Contractor, where the subcontract had involved similar nature of work as described in the scope of works in this bid document, provided further that all other qualification criteria are satisfied)

- a) Three similar completed works of similar nature each costing minimum of

Rs.3.03 Lakhs OR

- b) Two similar completed works of similar nature each costing minimum of

Rs.3.53 Lakhs OR

- c) One completed work of similar nature of minimum of **Rs.5.05 Lakhs**

The value of executed works shall be brought to current costing level by enhancing the actual value of work at compound rate of 10 % per Annam, calculated from the date of completion to last date of receipt of applications for tenders.

Tenderer shall upload documentary evidence for eligibility along with the tender.

1.2 Financial capacity:

Achieved an average annual financial turnover as certified by 'Chartered Accountant' equal to **Rs.3.03 Lakhs in last three (3) financial years** immediately preceding the Financial Year in which bids are invited. The value of executed works shall be brought to current costing level by enhancing the actual value of work at compound rate of 10 % per annum; calculated from the date of completion to last date of receipt of applications for tenders.

Documentary evidence shall be submitted.

1.3 Similar Experience:

- For assessing the technical capacity of Regular, Routine & Maintenance works; the similar work shall mean SITC of Trash Rack cleaning Machine (TRCM)/ O & M of Trash cleaning machine or Pumping station of minimum 450MLD capacity.
- Past performance certificates, including the work order number and date, cost of the work, contract period, etc. shall be annexed by the bidder while submitting the offer.

C.

- **Bid Capacity: (Not Applicable for this tender)**

~~• The bid capacity of the prospective bidders will be calculated as under:~~

~~• Assessed Available Bid Capacity = (A* N* 2 - B)~~

~~• Where,~~

~~• A = Maximum value of Civil Engineering works executed in any one year (year means Financial year) during the last five years (updated to the price level of the Financial year in which bids are received at a rate of 10% per year) taking into account the completed as well as works in progress.~~

~~• N = Number of years prescribed for completion of the Project/Works, excluding monsoon period, for which these bids are being invited. (E.g. 7 months = 7/12 year) For every intervening monsoon 0.33 shall be added to N.~~

~~• B = Value of existing commitments (only allotted works) on the last date of submission of bids as per bidding document and on going works to be completed during the period of completion of the Project/Works for which these bids are being~~

invited.

• **Note:** ~~The statement showing the value of existing commitments and on-going works as well as the stipulated period of completion remaining for each of the works listed should be attached along with certificates duly signed by the Engineer in Charge, not below the rank of an Executive Engineer or equivalent.~~

~~• **Even though the bidders meet the above qualifying criteria, they are subject to be disqualified if they have:**~~

~~• made misleading or false representation in the forms, statements and attachments submitted in proof of the qualification requirements; and/or~~

~~• **Record for poor performance such as abandoning the works, not properly completing the contract, inordinate delays in completion, litigation history, or financial failures etc.**~~

D. Equipment Capabilities as required for this work:

a) Regular and Routine works: The successful bidder will make the arrangements of the required equipment on the day of commencement or with respect to the progress of the work in phases, as per the instructions of site in charge. The successful bidder and, to that effect he will ensure commitment on an undertaking on Rs.500 stamp paper to be submitted along with the Bid in Packet B. However, this condition in no way shall dilute the respective condition in Registration Rules of BMC.

~~**b) New and Original Works:** The bidder should, undertake their own studies and furnish with their bid, a detailed construction planning and methodology supported with assessment study of requirements of equipment/plants & machineries to allow the employer to review their proposal. The bidder will ensure his commitment to make the arrangements of the required equipment on the day of commencement or with respect to the progress of the work in phases, as per the instructions of site in charge on an undertaking on Rs.500 stamp paper to be submitted along with the Bid in Packet B. However, this condition in no way shall dilute the respective condition in Registration Rules of MCGM.~~

~~**c) Special Works:** The concerned Ch.Eng. shall enlist the equipments in the tender document justified for the project and ensure the capacity of the bidder for the same with the approval of concerned AMC.~~

Note:

1. Bidders shall submit the undertaking for equipment capability and other undertakings as such on a single Rs.500/- stamp paper.
2. Insistence of availability of equipments/plants at a particular distance from site should not be made in the tender document.

E. Technical Personal

For fixing requirement of Technical staff as required for this work shall be as follows:-

Cost of work (Rs. In Crores)	Requirement of Technical Staff		Minimum Experien ce (year)	Designation
	Qualification	Number		
10 to 20 (Not applicable)	i) Project Manager with degree in corresponding discipline of Engineering	1	10	Principal Technical Representative
		1	5	Technical Representative
	ii) Graduate Engineer	2	2	Project/Site Engineer and
	iii) Graduate Engineer — or — Diploma Engineer	2	5	Project Planning/ billing Engineer
5 to 10 (Not applicable)	i) Graduate Engineer	1	5	Principal Technical Representative
	ii) Graduate Engineer — or — Diploma Engineer	2	2	Project/Site Engineer Engineer
More than 1.5 to 5 (Not applicable)	i) Graduate Engineer	1	5	Principal Technical Representative
	ii) Graduate Engineer — or — Diploma Engineer	1	2	Project/Site Engineer
		1	5	Billing Engineer
Up to 1.5	1. Graduate Engineer — or	1	2	Principal Technical Representative
	2. Diploma Engineer	1	5	Project / Site Engineer / Billing Engineer

Note:- 1. 'Cost of work' in table above shall mean the agreement amount of the work.
2. Rate of recovery in case of non-compliance of the clause be stipulated at following rate.

Sr. NO.	Qualification	Experience	Rate of recovery
1	Project Manager with degree	10	Rs.30,000/ p.m.
2	Graduate Engineer	5	Rs.25,000/ p.m.
3	Graduate Engineer	2	Rs.15,000/ p.m.

4	Project / Site Engineer / Billing Engineer	5	Rs.15,000/- p.m.
---	--	---	------------------

F. TIME PERIOD OF THE PROJECT :

Entire project should be completed and delivered within **Six Months (IM)** of time from the date of award of purchase order. The time allowed for carrying out the work **(including monsoon)** as entered in the Tender shall be strictly observed by the Contractor. The work shall throughout the stipulated period of the Contract be proceeded with all due diligence as time being deemed to be the essence of the contract on the part of the Contractor. On failing to do so, the Contractor shall pay as compensation an amount which shall be governed as per Clause - 84 of Standard General Conditions of Contract.

The Contractor should complete the work as per phase given below:

~~1/4 of the work in .. 1/4 of the time,~~

~~1/2 of the work in .. 1/2 of the time,~~

~~3/4 of the work in .. 3/4 of the time~~

~~Full of the work in .. Full of the time~~

Full work shall be completed in **Six Months (IM)** of time from the date of award of purchase order. ~~The time allowed for carrying out the work.~~

~~————— The program for completion of work shall be a part of the Contract Document in the form of Bar Chart / GANTT Chart. The Contractor is supposed to carry out the work and keep the progress as per Bar Chart/GANTT Chart. The Contractor shall complete the work as per the Schedule given in the Contract and the program submitted by the Contractor.~~

G. Contract Execution

All required documents for execution of the contract shall be submitted within 30 days from the date of issue of letter of acceptance. **If the documents are not submitted within the stipulated time a penalty of Rs 5000/- per day will be applicable to the contractor.** All contract documents need to be duly affixed with stamp duty properly signed along with evidence/proof of payment of security/contract deposit within 30 days from the date of letter of acceptance received by him.

H. If the amount of the Contract Deposit to be paid above is not paid within 30 days from the date of issue of Letter of Acceptance, the Tender / Contractor already accepted shall be considered as canceled and legal steps be taken against the contractor for recovery of the amounts.

I. The amount of Security Deposit retained by the BMC shall be released after expiry of period up to which the contractor has agreed to maintain the work in good order is over. In the event of the contractor failing or neglecting to complete the rectification work within the period up to which the contractor has agreed to maintain the work in good order, the amount of security deposit retained by BMC shall be adjusted to-wards the excess cost incurred by the Department on rectification work.

J. Action when whole of security deposit is forfeited:

In any case in which under any Clause of this contract, the contractor shall have rendered himself liable to pay compensation amounting to the whole of this security deposit whether paid in one sum or deducted by installments or in the case of abandonment of the work owing to serious illness or death of the contractor or any other cause, the Engineer on behalf of the Municipal Commissioner shall have power to adopt any of the following process, as he may deem best suited to the interest of BMC -

(a) To rescind the contract (for which recession notice in writing to the contractor under the head of Executive Engineer shall be conclusive evidence) and in that case, the security deposit of the contract shall stand forfeited and be absolutely at the disposal of BMC.

(b) To carry out the work or any part of the work departmentally debiting the contractor with the cost of the work, expenditure incurred on tools and plant, and charges on additional supervisory staff including the cost of work-charged establishment employed for getting the unexecuted part of the work completed and crediting him with the value of the work done departmentally in all respects in the same manner and at the same rates as if it had been carried out by the contractor under the terms of his contract.

The certificate of the Executive Engineer as to the costs and other allied expenses so incurred and as to the value of the work so done departmentally shall be final and conclusive against the contractor.

(c) To order that the work of the contractor be measured up and to take such part thereof as shall be un-executed out of his hands, and to give it to another contractor to complete, in which case all expenses incurred on advertisement for fixing a new contracting agency, additional supervisory staff including the cost of work charged establishment and the cost of the work executed by the new contract agency will be debited to the contractor and the value of the work done or executed through the new contractor shall be credited to the contractor in all respects and in the same manner and at the same rates as if it had been carried out by the contractor under the terms of his contract. The certificate of the Executive Engineer as to all the cost of the work and other expenses incurred as aforesaid for or in getting the un-executed work done by the new contractor and as to the value of the work so done shall be final and conclusive against the contractor.

In case the contract shall be rescinded under Clause (a) above, the contractor shall not be entitled to recover or be paid any sum for any work therefor actually performed by him under this contract unless and until the Executive Engineer shall have certified in writing the performance of such work and the amount payable to him in respect thereof and he shall only be entitled to be paid the amount so certified. In the event of either of the courses referred to in Clause (b) or (c) being adopted and the cost of the work executed departmentally or through a new contractor and other allied expenses exceeding the value of such work credited to the contractors amount of excess shall be deducted from any money due to the contractor, by BMC under the contract or otherwise, howsoever, or from his security deposit or the sale proceeds thereof provided, however, the contractor shall have no claim against BMC even if the certified value of the work done departmentally or through a new contractor exceeds the certified cost of such work and allied expenses, provided always that whichever of the three courses mentioned in clauses (a), (b) or (c) is adopted by the Executive Engineer, the contractor shall have no claim to compensation for any loss sustained by him by reason of his having purchase or procured any materials or entered in to any engagements or made any advance on account of or with a view to the execution of the work or the performance of the contract.

K. Contract may be rescinded and security deposit forfeited for bribing a public officer or if contractor becomes insolvent

If the contractor assigns or sublets his contracts or attempt so to do, or become insolvent or commence any proceeding to get himself adjudicated and insolvent or make any composition with his creditors, or attempt so to do or if bribe, gratuity, gift, loan, perquisite, reward or advantage, pecuniary or otherwise, shall either directly or indirectly be given promised or offered by the contractor or any of his servants or agents through any public officer, or person in the employ of BMC/Govt. in any way relating to his office or employment, or if any such officer or person shall become in any way directly or indirectly interested in the contract the Engineer In-charge may thereupon, by notice in writing rescind the contract and the Security Deposit of the Contractor shall thereupon stand

forfeited and be absolutely at the disposal of BMC and the same consequences shall ensure as if the contract had been rescinded under above clause J hereof; and in addition the contractor shall not be entitled to recover or be paid for any work therefore actually performed under the contract.

Submission of Tenders

PACKET – A

The Packet 'A' shall contain scanned certified copies of the following documents

Scrutiny of this packet will be done strictly with reference to only the scanned copies of Documents uploaded online in packet 'A'

- a) Valid BMC Registration Certificate
- b) Valid Bank Solvency Certificate of Minimum Solvency amount of **Rs. 4 lakhs** as governed by Registration Rules in force for respective Class of Contractor M&E works.
- c) ~~A document in support of Registration under Maharashtra GST Act 2017. GST Registration Certificate in Maharashtra. Those not registered in Maharashtra shall submit an undertaking to the effect that if they are successful tenderer, they shall submit GST Registration Certificate in Maharashtra within 15 days of issue of work order, failing which payment for the work executed will not be released.~~ Valid GST registration certificate.
- d) Certified copies of valid 'PAN' documents and photographs of the individuals, owners, Karta of Hindu undivided Family, firms, private limited companies, registered co-operative societies, partners of partnership firms and at least two Directors, if number of Directors are more than two in case of Private Limited Companies, as the case may be. However, in case of Public Limited companies, Semi Government Undertakings, Government Undertakings, no 'PAN' documents will be insis

ted.

- e) Latest Partnership Deed in case of Partnership firm duly registered with Chief Accountant (Treasury) / C.A.(WSSD) of BMC.
- f) No litigation history undertaking.
- g) ~~The manufacturer's Authorization certificate.~~

The bidders shall categorically provide their valid Email-ID in packet 'A'.

NOTE:

- If the tenderer(s) withdraw tender offer during the tender validity period, his entire E.M.D shall be forfeited.**
- If it is found that the tenderer has not submitted required documents in Packet "A" then, the shortfalls will be communicated to the tenderer through e-mail only and compliance required to be made within a time period of three working days otherwise they will be treated as non-responsive.**

PACKET – B

The Packet 'B' shall contain scanned certified copies of the following documents –

a) The list of similar type of works as stated in eligibility criteria successfully completed during the last 7 years in prescribed proforma, in the role of prime contractor. Information furnished in the prescribed proforma (**Proforma – I**) shall be supported by the certificate duly self-attested. Documents stating that it has successfully completed during the last 7 years at least one contract of similar works as stated in eligibility criteria.

b) Annual financial turnover for preceding three financial years as certified by Chartered Accountant preceding the Financial Year in which bids are invited. Copies of Applicants duly audited balance sheet and profit and loss account for the preceding three financial years preceding the Financial Year in which bids are invited. (**Proforma II**)

~~**c)** unencumbered assets, lines of credit and other financial means (independent of any contractual advance payment) sufficient to meet the construction cash flow requirements for the subject contract in the event of stoppage, start up, or other delay in payment, of the minimum 15% of the cost of the work tendered for, net of the tenderer's commitment of other contracts (Certificate from Bankers / C.A./Financial Institution shall be accepted as a evidence). (**Not applicable for item rate Tender.**)~~

d) The bidder shall give undertaking on Rs 500/-stamp paper that it is his/their sole responsibility to arrange the required machineries either owned/on lease or hire basis, at site before start of the work.

i) Regular and Routine works: The successful bidder shall make the arrangements of the required equipments on the day of commencement or with respect to the progress of the work in phases, as per the instruction of site in charge. The successful bidder and to that effect he will ensure commitment on an undertaking on Rs. 500/- stamp paper to be submitted along with the bid in Packet B. However, this condition in no way shall dilute the respective conditions in Registration Rules of BMC.

Note:

Insistence of availability of equipments / plants at a particular distance from site should not be made in the tender document.

~~ii) New and Original Works: The bidder should, undertake their own studies and furnish with their bid, a detailed construction planning and methodology supported with assessment study of requirements of equipment/plants & machinery to allow the employer to review their proposal. The bidder shall ensure his commitment to make the arrangements of the required equipment on the day of commencement or with respect to the progress of the work in phases, as per the instructions of site in charge on an undertaking on Rs.500 stamp paper to be submitted along with the Bid in Packet B. However, this condition in no way shall dilute the respective condition in Registration Rules of bmc~~

~~iii) Special Works: The concerned Ch.Eng. shall enlist the equipments in the tender document justified for the project and ensure the capacity of the bidder for the same with the approval of concerned AMC.~~

Note:

~~Insistence of availability of equipments/plants at a particular distance from site should not be made in the tender document~~

iv) Details of works in hand (Proforma VI-A & VI-B) (original), along with copies of work orders & attested copies of percentage of works completed or part thereof.

~~**v)** Statement showing assessed available Bid Capacity~~

vi) The undertaking of Rs.500/- stamp paper as per the proforma annexed in '**Annexure A, B & C**' and for **Best price** (Also Bidders shall submit the undertaking for equipment capability and other undertakings as such on a single Rs.500/- stamp paper).

vii) The tenderer shall upload work plan as per the following outline:

- ~~1. GANTT chart/ PERT/ CPM chart showing the completion of work within prescribed time period, considering major activities.~~
- ~~2. Organizational set up envisaged by the contractors.~~
- ~~3. Plant & equipment proposed to be deployed for this work. **(Not applicable)**~~
- ~~4. A note on how the whole work will be carried out (work plan including methodology).~~
- ~~5. Quality management plan.~~
6. Work plan includes all the activities in the Scope of Work.

viii) The tenderer shall submit the undertaking stating that he will submit license certification from office of labour commissioner after issue of work order and before commencing the work if the work is allotted to him . The undertaking on Rs.500/- stamp paper)

~~**e) Copy of Manufacturer's authorization certificate as per attached format in draft tender for authorized dealer/distributor/contractor/firm who is tenderer.**~~

Note:

~~**i.** The Electrical / Mechanical work shall be got carried out by the civil contractors through the contractors registered with MCGM. in Electrical Category. Information about the registered contractors shall be obtained from the office of the Ch.E. (M&E)/ E.E. (Monitoring & Registration Cell). Attested scanned copy of the valid registration certificate in Electrical Category shall be uploaded with the tender along with the undertaking from the registered Electrical Contractor stating his willingness to carry out the tender work.~~

ii. The successful bidder shall submit valid registration certificate under E.S.I.C., Act 1948, if the tenderer has more than 10 employees /persons on his establishment (in case of production by use of energy) and 20 employees/persons on his establishment (in case of production without use of energy) to BMC as and when demanded. In case of less employees/persons mentioned above then the successful bidder has to submit an undertaking to that effect on Rs. 200 stamp paper as per circular u/no. CA/FRD/I/65 of 30.03.2013.

iii. The successful bidder shall submit valid registration certificate under E.P.F. & M.P., Act 1952, if tenderer has more than 20 employees/persons on his establishment, to BMC as and when demanded. In case if the successful bidder has less employees/persons mentioned above then the successful bidder has to submit an undertaking to that effect on Rs. 200 stamp paper as per circular u/no. CA/FRD/I/44 of 04.01.2013.

Note:

If it is found that the tenderer has not submitted required documents in Packet "B" then, the shortfalls will be communicated to the tenderer through e-mail only and compliance re-quired to be made within a time period of three working days otherwise they will be treated as non-responsive.

Packet- C

Tenderer shall submit the price bid in packet 'C' by filling data in 'Financial' Packet during the submission of the bid.. The tenderer shall quote inclusive of all taxes other than GST (Excluding GST), Levies, Duties, Cess etc as applicable at the time of bid submission. GST as applicable shall be paid separately on submission of bills/invoice.

BID SECURITY OR EMD

The Bidder shall furnish, as part of the Bid, Bid Security/EMD, in the amount specified in the Bid Data Sheet. This bid security shall be in favor of the authority mentioned in the Bid Data Sheet and shall be valid till the validity of the bid.

A tenderer shall pay entire amount of EMD through payment gateways of GoM on URL <http://mahatenders.gov.in>. The bidder shall upload scan copy of online paid EMD along with the bid submission in packet 'A'. Any bid not accompanied by an acceptable Bid Security shall be rejected by the Employer as non-responsive.

Any bid not accompanied by an acceptable Bid Security and not secured as indicated in sub-clause mentioned above, shall be rejected by the Employer as non-responsive.

The Bid Security of the successful Bidder will be discharged when the Bidder has signed the Agreement and furnished the required Security Deposits.

a) Except successful bidder all other unsuccessful bidders' 100% EMD paid online will be refunded automatically.

b) The Bid security of successful bidder will be discharged when the bidder has signed the agreement and /or furnish the required Security Deposits as elaborated in Standard Bid Document.

The Bid Security may be forfeited:

a) if the Bidder withdraws the Bid after bid opening (opening of technical qualification part of the bid during the period of Bid validity;

b) in the case of a successful Bidder, if the Bidder fails within the specified time limit to:

i. sign the Agreement; and/or

ii. Furnish the required Security Deposits.

1. The cases wherein if the shortfalls are not complied by a contractor, will be informed to Registration and Monitoring Cell. Such non-submission of documents will be considered as 'Intentional Avoidance' and if three or more cases in 12 months are re-reported, shall be viewed seriously and disciplinary action against the defaulters such as banning/de-

registration, etc. shall be taken by the registration cell with due approval of the concerned AMC.

2. If non-responsive; If the bidder is found non-responsive after scrutiny of packet 'A'/'B', in such circumstances, the bidder will be made non-responsive and financial packet 'C' of non-responsive bidder will not be opened. However there will not be any forfeiture of EMD.

Note:

i) Curable Defect shall mean shortfalls in submission such as:

a. Non-submission of following documents,

i. Valid Registration Certificate

ii. Valid Bank Solvency

iii. GST Certificate

iv. Certified Copies of PAN documents and photographs of individuals, owners, etc

v. Partnership Deed and any other documents

vi. Undertakings as mentioned in the tender document.

b. Wrong calculation of Bid Capacity, (deleted and move to Non curable defect as per circular no.CHE/BM/019919/II dt. 07.01.2019).

c. No proper submission of experience certificates and other documents, etc.(deleted and move to Non curable defect as per circular no.CHE/BM/019919/II dt. 07.01.2019).

~~Note: In Packet 'A' as well as packet B, 02 nos. Of shortfall in curable defect will be allowed & 2 % EMD will be forfeited for each shortfall thereafter.~~

Shortfalls: Maximum 5 shortfalls of curable defects shall be allowed and in case, curable defects are not compiled by bidder within given time period, the bidder shall be treated as **Non-Responsive** & such cases will be informed to Registration and Monitoring Cell Such non-submission of documents will be considered as 'Intentional Avoidance' and if three or more cases in 12 months are reported, shall be viewed seriously and disciplinary action against the defaulters such as banning/de registration, etc. shall be taken by Registration Cell with due approval of the concerned AMC.(CA/Finance/Project/19 dt 04.03.2024)

ii) Non-curable Defect shall mean

a. In-adequate submission of EMD/ASD amount,

b. In-adequacy of technical and financial capacity with respect to Eligibility criteria as stipulated in the tender.

c. Wrong calculation of Bid Capacity (Not Applicable).

d. No proper submission of experience certificates and other documents, etc.

BID VALIDITY □ **Bids shall remain valid for a period of not less than one eighty (180) days after the deadline date for bid submission specified in Bid Data Sheet. A bid valid for a shorter period shall be rejected by the Employer as non-responsive.**

□ In exceptional circumstances, prior to expiry of the original time limit, the Employer may request that the bidders may extend the period of validity for a specified additional period. The request and the bidders' responses shall be made in writing or by cable. A bidder may refuse the request without forfeiting his Bid Security. A bidder agreeing to the request will not be required or permitted to modify his bid, but will be required to extend the validity of his bid security for a period of the extension.

DEFECT LIABILITY PERIOD

□ The Contractor is expected to carry out the construction work in Workmen like manner so as to meet the requirement and specification for the project. It is expected that the Workmanship and materials will be reasonably fit for the purpose for which they are required.

□ Defects or defective work is where standard and quality of workmanship and materials as specified in the contract is deficient. Defect is defined as a failure of the completed project to satisfy the express or implied quality or quantity obligations of the construction contract. Defective construction works are as the works which fail short of complying with the express descriptions or requirements of the contract, especially any drawings or specifications with any implied terms and conditions as to its quality, workmanship, durability, aesthetic, performance or design. Defects in construction projects are attributable to various reasons.

~~□ Some of the defects are structural defects results in cracks or collapse of faulty defective plumbing, inadequate or faulty drainage system, inadequate or faulty ventilation, cooling or heating systems, inadequate fire systems etc. The defects could be various on accounts of different reasons for variety of the projects.~~

□ The Engineering In charge / Project Officer shall issue the practical completion certificate for the project. During the Defect Liability Period which commences on completion of the work, the Engineering In charge shall inform or the contractor is expected to be informed of any defective works by the Employer's representative of the defects and make good at contractor's cost with an intention of giving opportunity to the contractor of making good the defects appeared during that period. It is the contractor's obligation under the contract to rectify the defects that appear during Defect Liability Period and the contractor shall within a reasonable time after receipt of such instructions comply with the same at his own cost. The Engineering In charge/Project Officer shall issue a certificate to that effect and completion of making good defects shall be deemed for all the purpose of this contract to have taken place on the day named in such defect liability certificate.

□ If defective work or workmanship or design have been knowingly covered-up or concealed so as to constitute fraud, commencement of the Defect Liability Period may be delayed. The decided period may be delayed until discover actually occurs on at least the defect could have been discovered with reasonable diligence, whichever is earlier.

□ **The DLP for this work shall be 3 years. (DLP not applicable, being a service contract)**

□ Also, in case of defect, the Engineer shall give notice to the Contractor of any Defects before the end of the Defects Liability Period, which begins at. The Defects Liability Period shall be extended for as long as Defects remain to be corrected. Every time notice of Defect/Defects is given, the Contractor shall correct the notified Defect/Defects within the duration of time specified by the Engineer's notice. The Engineer may issue notice to the Contractor to carry out removal of defects or deficiencies, if any, noticed in his inspection, or brought to his notice. The Contractor shall remove the defects and deficiencies within the period specified in the notice and submit to the Engineer a compliance report.

□ It is the Completion Stage when the contractor has completed all of the works and fixed all of the defects that were on the list of issue by Engineer-in-charge. When this happens, the engineer must issue a 'Certificate of Completion'. On the issue of 'Certificate of Completion', the 'Defect Liability Period' starts. The contractor also must issue a 'Certificate statement' as an acknowledgment to the engineer not later than 14 days after the 'Certificate of Completion' has been issued. During the 'Defect Liability Period', the contractor has to obey all written instructions from the engineer to carryout repairs and fix any defects which appear in the Permanent Works. If the contractor does not ,due to his

own faults finish the repair works or fix the defects by the end of 'Defect Liability Period', the 'Defect Liability Period' will continue until all works instructed by engineer is done.

During the Defects Liability Period (DLP), the completed work shall be periodically inspected by the site staff along with the contractor and defects noticed, if any shall be got rectified immediately from the contractor as per provision of contract. The above compliance report shall be mandatory prerequisite before releasing the deposit/retention money of the work. The concern Account Officer shall confirm in this regards. Alternatively, the inspection of DLP roads during DLP period can also be entrusted to contractor's engineer and modality can be decided by the user department and accordingly, there can be tender condition.

SECURITY DEPOSIT AND PERFORMANCE GUARANTEE

A. Security Deposit

The security deposit shall mean and comprise of

I) Contract Deposit and

~~II) Retention Money.~~

I) **Contract Deposit** – The successful tender, here after referred to as the contractor shall pay an amount equal to **two (2)** percent of the contract sum shall be paid within thirty days from the date of issue of letter of acceptance.

The successful tender, here after referred to as the contractor shall pay an amount equal to two (2) percent of the contract sum shall be paid within thirty days from the date of issue of letter of acceptance. **The said contract deposit shall be paid in the form of Demand Draft (D.D.) only**

~~II) Retention Money~~ – The retention money equal to 15.00% of the Contract

~~Sum will be recovered from the contractors every bill i.e.interim/running/final bill. The clause of retention money will not be applicable M & E Department.~~

III) **Additional Security Deposit (ASD) : - (Applicable only for Percentage Rate tender)**

The Additional Security Deposit shall be applicable as under:

Rebate quoted by contractor	ASD Applicable
Up to 12 % Rebate	No ASD
Rebate above 12.00 % on estimated cost	At 2.00% of Estimated cost for each % rebate & part thereof, in D. D. only

The bidders shall submit the ASD as applicable in the form of Demand Draft, which is to be submitted during office hours minimum one day before opening of packet 'C' to respective Head Clerk (Expenditure) of the Engineer in-charge of the HE Division in sealed envelope. If ASD is not applicable then the bidders shall submit sealed envelope mentioning on their letter head 'ASD is not applicable'.

If the bidders fails to submit the sealed envelope as mentioned above at least one day before opening of packet 'C' within office hours then the EMD of the respective bidders will be forfeited and the company with their Directors/Partners and other companies with the said Directors / Partners will be further debarred from any tendering process for the period of at least 2 years

~~B. Performance Guarantee (Not Applicable)~~

~~The successful tenderer, here after referred to as the contractor shall pay amount in the form of "Performance Guarantee" at different rates for different slabs as stated below:~~

Offer	PG applicable %
For premium, at par and rebate less 0 to 12%	PG= 0.92% x contract sum applicable for rebate upto 12%
For rebate of 12.01% and more	P.G. = {0.92% x contract sum applicable for rebate of 12%} +(X) x contract sum where X= percentage rebate quoted more than 12%

~~Note: Contract sum shall mean amount after application of rebate/premium as quoted by the contractor with contingencies only and excluding price variation.~~

~~Note: Contract sum shall mean amount after application of rebate/premium as quoted by the contractor with contingencies only and excluding price variation.~~

~~The PG shall be paid in one the following forms.~~

~~I) Cash (In case guarantee amount is less than Rs.10,000/-~~

~~II) Demand Draft (In case guarantee amount is less than Rs.1,00,000/-)~~

~~III) Government securities~~

~~IV) Fixed Deposit Receipts (FDR) of a Schedule Bank.~~

~~V) An electronically issued irrevocable bank guarantee bond of any Schedule bank or f in the prescribed form given in Annexure.~~

~~Performance Guarantee is applicable over and above the clause of Security Deposit. Performance Guarantee will have to be paid & shall be valid till the defect liability period or finalization of final bill whichever is later.~~

~~This deposit will be allowed in the form of I to V as mentioned above and shall be paid within 15 days after receipt of Letter of Acceptance.~~

~~C. Refund of Security Deposit~~

~~I. Refund of Contract Deposit~~

~~The Contract Deposit shall be released within 30 days after completion of 3rd year of DLP (in case of 5 years DLP) and after issue of 'Defect Liability Certificate' (in case of 1 or 2 or 3 years DLP) subject to no recoveries are pending against the said work, provided that the Engineer is satisfied that there is no demand outstanding against the Contractor. No claim shall be made against the Balance Contract Deposit after the issue of Defects Liability Certificate.~~

~~II. Refund of Performance Guarantee~~

~~The Deposit on account of performance guarantee shall be released within 30 days of completion of Defects Liability Certificate subject finalization of final bill whichever is later and no recoveries are pending against the said work, provided that the Engineer is satisfied that there is no demand outstanding against the Contractor.~~

~~*Note:~~

a) ~~It shall be clearly mentioned that the BG shall be applicable for individual work/contract and clubbing of various contracts of the said contractor will not be allowed. **In case of obtaining Bank Guarantee, it is necessary to mention that the same shall be valid further 6 months from the completion of defect liability period/ warranty period.**~~

b) ~~It shall be the responsibility of the bidder to keep the submitted B.G. "VALID" for the stipulated time period in the tender & in case of its expiry it will attract penalization.~~

c) ~~Bank Guarantee should be issued by way of General Undertaking and Guarantee issued on behalf of the Contractor by any of the Nationalized or Scheduled banks or branches of foreign banks operating under Reserve Bank of India regulations located in Mumbai upto Virar & Kalyan. List of approved Banks is appended at the end of Instructions to Bidders (ITB). The Bank Guarantee issued by branches of approved Banks beyond Kalyan and Virar can be accepted only if the said Bank Guarantee is countersigned by the Manager of a Regional Branch of the same bank within the Mumbai City Limit categorically endorsing thereon that the said Bank Guarantee is binding on the endorsing Branch of the Bank or the Bank itself within Mumbai Limits and is liable to be enforced against the said Branch of the Bank or the bank itself in case of default by the Contractors furnishing the Bank Guarantee. The Bank Guarantee shall be renewed as and when required and/or directed from time to time until the Contractor has executed and completed the works and remedied any defects therein.~~

III) Refund of Additional Security Deposit (Applicable only for Percentage Rate tender)

One-half (50 %) of the additional security deposited (ASD) shall be released after the completion of 50% financial progress of the work. The balanced ASD shall be released within 30 days of issue of 'Certificate of Completion' with respect to the whole of the Works. In the event the Engineer issues a Taking-over Certificate for a section or part of the Permanent Works, only such proportion thereof as the Engineer determines (having regard to the relative value of such section or part of the Works) shall be considered by the Engineer for Refund of ASD to the contractor.

D Legal + Stationary Charges: (As per applicable circular)

Successful tender shall pay the Legal Charges +Stationary charges as per modified Circular no 26206 dated 31.08.2023 of legal dept (effective from 01.04.2023 to 31.03.2024). additional 18 % GST will be applicable.

Sr. No.	Contract Value in Rs.	Legal Charges in Rs.
1	Upto to Rs. 50,000/-	Nil
2	From 50,001/- to 1,00,00,000/-	0.10% of contract cost , round to the next 100 + 18 % GST(minimum 1000/- & maximum 10000/- + 18 % GST)
3	From 1,00,00,001/-- to 10,00,00,000/-	contract value Upto1,00,00,000/- Rs. 10000/- plus 0.05% of contract cost above 1,00,00,001/- round to the next 100 + 18 % GST

The tenderers are requested to note that stationary charges as given in the table above will be recovered from the successful tenderer for supply of requisite prescribed forms for preparing certificate bills in respect of the work.

E. Stamp Duty: - It shall be incumbent on the successful tenderer to pay stamp duty on the contract.

i. As per the provision made in Article 63, Schedule I of Bombay Stamp Act 1958, stamp duty is payable for "works contract" that is to say, a contract for works and labour or

services involving transfer of property in goods (whether as goods or in some other form) in its execution and includes a sub-contract, as under :

(a)	Where the amount or value set forth in such contract does not exceed rupees ten lakh.	Five Hundred rupees stamp duty
(b)	Where it exceeds rupees ten lakhs	Five hundred rupees plus 0.1% of the amount above rupees ten lakhs subject to maximum of rupees twenty five lakhs.

F. Stamp duty on Bank Guarantee : As per article 54 read with 40 (b) of stamp duty act, stamp duty of **0.5%** will be applicable to the all bank guarantee submitted also which are required to be renewed after expiry of time period.

It shall be incumbent on the successful tenderer to pay stamp duty on the contract.

i. As per the provision made in Article 63, Schedule I of Bombay Stamp Act 1958, stamp duties payable for “works contract” that is to say, a contract for works and labour or services involving transfer of property in goods (whether as goods or in some other form) in its execution and includes a sub-contract, as under :

ii. The successful bidder shall enter into a contract agreement with B.M.C.. within 30 days from the date of issue of Work Order and the same should be adjudicated for payment of Stamp Duty by the successful bidder.

iii. Further shortfall if any, in amount of stamp duty paid as against prescribed amount for the documents executed in Mumbai City & Mumbai Suburban District be _____ recovered from the concerned work contractors and to deposit the deficit or unpaid _____ Stamp Duty and penalty by two separate Demand Draft or Pay Order in favour of _____ “Superintendent of Stamp, Mumbai” within 15 days from intimation thereof.

iv. All legal charges and incidental expenses in this respect shall be borne and paid by the successful tenderer.

IMPORTANT DIRECTIONS

1. All the information uploaded shall be supported by the corroborative documents in absence of which the information uploaded will be considered as baseless and not accepted for qualification criteria. All the documents shall be uploaded with proper pagination. The page No. shall be properly mentioned in the relevant places.

The information shall be uploaded in the sequence as asked for with proper indexing etc. The Bidder shall be fully responsible for the correctness of the information uploaded by him.

2. Applicants/Bidders shall refer www.mahatenders.gov.in for ‘Bidders Manual Kit’ - Open Source Software Link. The detail guidelines for creation and submission of bid are available in the referred document.

Any queries or request for additional information concerning this TENDER shall be submitted by e-mail to at the address of **eemnemcgmprise@gmail.com** of the office of Dy.H.E.(PPC). The subject shall clearly bear the Tender identification/ title: "Queries/ Request for Additional Information. Any changes in mail ID will be intimated on the portal.

3. In case of Equal quoted cost of lowest bidders (L1), the allotment of work shall be done by giving 48 hrs (2 working days) from the day of opening of packet C on same BID Document number for re-quoting and such development needs to done by IT department in BMC's SRM system. Till such development is made; ‘Sealed Bids’ shall be called from the bidders quoting the same rates i.e. L1.

~~In case of equal quoted cost of lowest bidders is obtained even after re quoting, then the successful bidder will be decided by lottery system by H.E.~~

~~Also, the Performance Guarantee shall be paid in 15 days after receipt of Letter of Acceptance.~~

Scrutiny Fee Note :As per Circular no. CA/FRG/10 dtd. 19.10.2023, all the tenderers shall have to pay the scrutiny fee with GST. It is to be paid at CFC center by obtaining challan from respective section before opening of packet C

Successful tender shall pay the Scrutiny fee as per Circular no CA/FRG/18 dtd. 27.02.2024 valid upto 31.03.2025.

Sr. No.	Estimated Value in Rs.	Scrutiny Fee in Rs.
1	Rs. 5,00,001 to Rs. 10,00,000/-	1320/- + 18% GST
2	Rs. 10,00,001 to Rs. 25,00,000/-	3300/- + 18% GST
3	Rs. 25,00,001 to Rs. 50,00,000/-	6600/- + 18% GST

SECTION 7
SCOPE OF WORK

SCOPE OF WORK

The scope of work for **“Operation of Trash Rack cleaning machine installed near Pumping station Pise for the period of one year”**, as per Technical specification at section 10 of tender document.

SECTION 8
BILL OF QUANTITIES

BRIHANMUMBAI MUNICIPAL CORPORATION

Hydraulic Engineer's Department

Subject: Operation of Trash Rack Cleaning Machine (TRCM) installed in the intake channel of Pumping station Pise for the period of Six months

DUE DATE:

SCHEDULE OF QUANTITIES & RATES

Sr. No.	Description	Unit	Qty.	Rate (Rs.)	Amount (Rs.)
(a)	(b)	(c)	(d)	(e)	(f)=(d)x(e)
1.	Operation of Trash rack cleaning machine (TRCM) & disposal of trashes as per scope of work for the period Six months.	Shifts	180		
				Total Rs.	

Note : Tenderer shall submit the price bid in packet 'C' by filling data in 'Financial' Packet during the submission of the bid.

The tenderer shall quote inclusive of all taxes other than GST (Excluding GST), Levies, Duties, Cess etc as applicable at the time of bid submission. GST as applicable shall be paid separately on submission of bills/invoice.

SECTION-09.
GENERAL CONDITIONS OF CONTRACT

Conditions of Contract

A. General

1. Definitions

1.1 Terms which are defined in the Contract Data are not also defined in the Conditions of Contract but keep their defined meanings. Capital initials are used to identify defined terms.

The “Contract” shall mean the tender and acceptance thereof and the formal agreement if any, executed between the Contractor, Commissioner and the Corporation together with the documents referred to therein including these conditions and appendices and any special conditions, the specifications, designs, drawings, price schedules, bills of quantities and schedule of rates. All these documents taken together shall be deemed to form one Contract and shall be complementary to one another.

The Contract Data defines the documents and other information which comprise the Contract.

The “Contractor” shall mean the individual or firm or company whether incorporated or not, whose tender has been accepted by the employer and the legal successor of the individual or firm or company, but not (except with the consent of the Employer) any assignee of such person.

The Bidder is a person or corporate body who has desired to submit Bid to carry out the Works, including routine maintenance till the tender process is concluded.

The Contractor's Bid is the completed bidding document submitted by the Contractor to the Employer.

The “Contract Sum” means the sum named in the letter of acceptance including Physical contingencies subject to such addition thereto or deduction there-from as may be made under the provisions hereinafter contained.

Note : The contract sum shall include the following –

- In the case of percentage rate contracts the estimated value of works as mentioned in the tender adjusted by the Contractor’s percentage.
- In the case of item rate contracts, the cost of the work arrived at after finalization of the quantities shown in schedule of items / quantities by the item rates quoted by the tenderers for various items and summation of the extended cost of each item.
- In case of lump sum contract, the sum for which tender is accepted.
- Special discount / rebate / trade discount offered by the tenderer if any and accepted by the Corporation.
- Additions or deletions that are accepted after opening of the tenders.

The "Contract Cost" means the Contract Sum. This cost shall be included in the letter of acceptance.

A Defect is any part of the Works not completed in accordance with the Contract.

The Defects Liability Certificate is the certificate issued by the Engineer, after the Defect Liability Period has ended and upon correction of Defects by the Contractor.

Drawings means all the drawings, calculations and technical information of a like nature provided by the Engineer to the Contractor under the Contract and all drawings, calculations, samples, patterns, models, operation & maintenance manual and other technical information of like nature submitted by the Contractor and approved by the Engineer.

The Authority shall mean BRIHANMUMBAI MUNICIPAL CORPORATION (BMC)

The "Employer" shall mean the Municipal Corporation for Greater Mumbai / Municipal Commissioner for Greater Mumbai, for the time being holding the said office and also his successors and shall also include all "Additional Municipal Commissioners, Director (Engineering Services & Projects)" and the Deputy Municipal Commissioner, to whom the powers of Municipal Commissioner, have been deputed under Section 56 and 56B of the Mumbai Municipal Corporation Act.

The Engineer in-charge shall mean the Executive Engineer in executive charge of the works and shall include the superior officers of the Engineering department i.e. Dy.Ch.Eng / Ch.Eng. and shall mean and include all the successors in BMC

The Engineer's Representative shall mean the Assistant Engineer, Sub. Engineer/Jr. Engineer in direct charge of the works and shall include Sub Eng./ Jr. Eng of Civil section/ Mechanical section/ Electrical section appointed by BMC.

The "Engineer" shall mean the City Engineer / the Hydraulic Engineer / the Chief Engineer / the Special Engineer, appointed for the time being or any other officer or officers of the Municipal Corporation who may be authorized by the commissioner to carry out the functions of the City Engineer / the Hydraulic Engineer / the Chief Engineer / the Special Engineer or any other competent person appointed by the employer and notified in writing to the Contractor to act in replacement of the Engineer from time to time.

Contractor's Equipment means all appliances and things of whatsoever nature required for the execution and completions of the Works and the remedying of any defects therein, but does not include plant material or other things intended to form or forming part of the Permanent Works.

The Initial Contract Price is the Contract Price listed in the Employer's Letter of Acceptance.

The Intended Completion Date is the date on which it is intended that the Contractor shall complete the construction works. The Intended Completion Date is specified in the Contract

Data. The Intended Completion Date may be revised only by the Engineer by issuing an extension of time.

Materials are all supplies, including consumables, used by the Contractor for incorporation in the Works and works of routine maintenance.

Plant is any integral part of the Works that shall have a mechanical, electrical, electronic, chemical, or biological function.

Routine Maintenance is the maintenance of activities of the completed structure for five years as specified in the Contract Data.

The "Site" shall mean the land and other places including water bodies more specifically mentioned in the special conditions of the tender, on, under in or through which the permanent works or temporary works are to be executed and any other lands and places provided by the Municipal Corporation for working space or any other purpose as may be specifically designated in the contract as forming part of the site.

Site Investigation Reports are those that were included in the bidding documents and are reports about the surface and subsurface conditions at the Site.

"Specification" shall mean the specification referred to in the tender and any modification thereof or addition or deduction thereto as may from time to time be furnished or approved in writing by the Engineer.

The Start Date/Commencement Date is given in the Contract Data. It is the date when the Contractor shall commence execution of the Works. It does not necessarily coincide with any of the Site Possession Dates.

A Nominated Sub-Contractor is a person or corporate body who has a Contract with the Contractor to carry out a part of the construction work and/or routine maintenance in the Contract, which includes work on the Site.

Temporary Works are works designed, constructed, installed, and removed by the Contractor that are needed for construction or installation of the Works.

Variation means a change to the:-

- i) Specification and /or Drawings (if any) which is instructed by the Employer.
- ii) Scope in the Contract which is instructed by the Employer.
- iii) Price in the Contract which is instructed by the Employer.

The Works, as defined in the Contract Data, are what the Contract requires the Contractor to construct, install, maintain, and turn over to the Employer. Routine maintenance is defined separately.

Jurisdiction: In case of any claim, dispute or difference arising in respect of a contract, the cause of action thereof shall be deemed to have arisen in Mumbai and all legal proceedings in respect of any claim, dispute or difference shall be instituted in a competent court in the City of Mumbai only.

2. Interpretation

2.1 In interpreting these Conditions of Contract, singular also means plural, male also means female or neuter, and the other way around. Headings have no significance. Words have their normal meaning under the language of the Contract unless specifically defined. The Engineer will provide instructions clarifying queries about these Conditions of Contract.

2.2 If sectional completion is specified in the Contract Data, references in the Conditions of Contract to the Works, the Completion Date, and the Intended Completion Date apply to any Section of the Works (other than references to the Completion Date and Intended Completion Date for the whole of the Works).

2.3 The documents forming the Contract shall be interpreted in the following documents: (1) Agreement, (2) Letter of Acceptance, (3) Notice to Proceed with the Work , (4) Contractor's Bid, (5) Contract Data, (6) Special Conditions of Contract Part (7) General Conditions of Contract Part I, (8) Specifications, (9) Drawings, (10) Bill of Quantities, and (11) Any other document listed in the Contract Data.

3 . Engineer's Decisions

3.1 Except where otherwise specifically stated, the Engineer will decide contractual matters between the Employer and the Contractor in the role representing the Employer. However, if the Engineer is required under the rules and regulations and orders of the Employer to obtain prior approval of some other authorities for specific actions, he will so obtain the approval, before communicating his decision to the Contractor.

3.2 Except as expressly stated in the Contract, the Engineer shall not have any authority to relieve the Contractor of any of his obligations under the contract.

4. Delegation

4.1 The Engineer, with the approval of the Employer, may delegate any of his duties and responsibilities to other person(s), except to the Adjudicator, after notifying the Contractor, and may cancel any delegation after notifying the Contractor.

5. Communications

All certificates, notices or instructions to be given to the Contractor by Employer/ Engineer shall be sent on the address or contact details given by the Contractor of Bid. The address and contact details for communication with the Employer/ Engineer shall be as per the details given in Contract Data. Communications between parties that are referred to in the conditions shall be in writing. The Notice sent by facsimile (fax) or other electronic means shall be effective on confirmation of the transmission. The Notice sent by Registered post or Speed post shall be effective on delivery or at the expiry of the normal delivery period as undertaken by the postal service.

6. Subcontracting

6.1 Unless specifically mentioned in the contract subletting will not be allowed. Subletting, where otherwise provided by the contract shall not be more than 25% of the contract price.

6.2 The Contractor shall not be required to obtain any consent from the Employer for:

- a. the sub-contracting of any part of the Works for which the Subcontractor is named in the Contract;
- b. the provision for labour, or labour component.
- c. the purchase of Materials which are in accordance with the standards specified in the Contract.

6.3 Beyond what has been stated in clauses 6.1 and 6.2, if the Contractor proposes sub contracting any part of the work during execution of the Works, because of some unforeseen circumstances to enable him to complete the Works as per terms of the Contract, the Employer will consider the following before according approval:

- a. The Contractor shall not sub-contract the whole of the Works.
- b. The permitted subletting of work by the Contractor shall not establish any contractual relation-ship between the sub-contractor and the BMC and shall not relieve the Contractor of any responsibility under the Contract.

6.4 The Engineer should satisfy himself before recommending to the Employer whether

- a. the circumstances warrant such sub-contracting; and
- b. the sub-Contractor so proposed for the Work possesses the experience, qualifications and equipment necessary for the job proposed to be entrusted to him.

7. Other Contractors

7.1 The Contractor shall cooperate and share the Site with other Contractors, public authorities, utilities, and the Employer between the dates given in the Schedule of Other Contractors, as referred to in the Contract Data. The Contractor shall also provide facilities and services for them as described in the Schedule. The Employer may modify the Schedule of Other Contractors, and shall notify the Contractor of any such modification.

7.2 The Contractor should take up the works in convenient reaches as decided by the Engineer to ensure there is least hindrance to the smooth flow and safety of traffic including movement of vehicles and equipment of other Contractors till the completion of the Works.

8. Personnel

8.1 The Contractor shall employ for the construction work and routine maintenance the key personnel including technical personnel named in the Contract Data or other personnel approved by the Engineer. The Engineer will approve any proposed replacement of technical personnel only if their relevant qualifications and abilities are substantially equal to those of the personnel stated in the Contract Data.

8.2 The Contractor's personnel shall appropriately be qualified, skilled and experienced in their respective trades or occupations. The Engineer shall have authority to remove, or cause to be removed, any person employed on the site or works, who carries out duties incompetently or negligently and persists in any conduct which is prejudicial to safety, health or the protection of the environment.

8.3 If the Engineer asks the Contractor to remove a person who is a member of the Contractor's staff or work force, stating the reasons, the Contractor shall ensure that the person leaves the Site within seven days and has no further connection with the Works in the Contract.

8.4 The Contractor shall not employ any retired Gazetted officer who has worked in the Engineering Department of the BMC /State Government and has either not completed two years after the date of retirement or has not obtained BMC/State Government's permission to employment with the Contractor.

9. Employer's and Contractor's Risks

9.1 The Employer carries the risks which this Contract states are Employer's risks, and the Contractor carries the risks which this Contract states are Contractor's risks.

10. Employer's Risks

10.1 The Employer is responsible for the excepted risks which are (a) in so far as they directly affect the execution of the Works in the Employer's country, the risks of war, invasion, act of foreign enemies, rebellion, revolution, insurrection or military or usurped power, civil war, riot, commotion or disorder (unless restricted to the Contractor's employees) and contamination from any nuclear fuel or nuclear waste or radioactive toxic explosive, or (b) a cause due solely to the design of the Works, other than the Contractor's design.

11. Contractor's Risks

11.1 All risks of loss of or damage to physical property and of personal injury and death which arise during and in consequence of the performance of the Contract other than the excepted risks, referred to in clause 11.1, are the responsibility of the Contractor.

12. Insurance

12.1 The Contractor at his cost shall provide, in the joint names of the Employer and the Contractor, insurance cover from the Start Date to the end of Defects Liability Period, in the

amounts and deductibles stated in the Contract Data for the following events which are due to the Contractor's risks:

- a) Loss of or damage to the Works, Plant and Materials;
- b) Loss of or damage to Equipment;
- c) Loss of or damage to property (other than the Works, Plant, Materials, and Equipment) in connection with the Contract; and d) Personal injury or death.

12.2 Insurance policies and certificates for insurance shall be delivered by the Contractor to the Engineer for the Engineer's approval before the Start Date. All such insurance shall provide for compensation to be payable in the types and proportions of currencies required to rectify the loss or damage incurred.

12.3 Alterations to the terms of insurance shall not be made without the approval of the Engineer.

12.4 Both parties shall comply with any conditions of the insurance policies.

~~12.5 If the Contractor does not provide any of the policies and certificates required, the Employer may affect the insurance which the Contractor should have provided and recover the premiums the Employer has paid, from payments otherwise due to the Contractor or if no payment is due, the payment of premiums shall be debt due.~~

13. Site Investigation Reports

13.1 The Contractor, in preparing the Bid, may rely, at his own risk, on any Site Investigation Reports referred to in the Contract Data, supplemented by any other information available to him, before submitting the bid.

14. Queries about the Contract Data

14.1 The Engineer will clarify queries on the Contract Data.

15. Contractor to Construct the Works and Undertake Maintenance (if specified in the tender)

15.1 The Contractor shall construct, and install and maintain the Works in accordance with the Specifications and Drawings and as per instructions of the Engineer.

15.2 The Contractor shall construct the works with intermediate technology, i.e., by manual means with medium input of machinery required to ensure the quality of works as per specifications. The Contractor shall deploy the equipment and machinery as required in the contract.

15.3 The Contractor shall take all reasonable steps to protect the environment on and off the Site and to avoid damage or nuisance to persons or to property of the public or others resulting from pollution, noise or other causes arising as a consequence of his methods of operation. During continuance of the contract, the Contractor and his sub-contractors shall abide at all times by all existing enactments on environmental protection and rules made there under, regulations, notifications and byelaws of the State or Central Government, or

local authorities and any other law, bye-law, regulations that may be passed or notification that may be issued in future by the State or Central Government or the local authority.

Salient features of some of the major laws that are applicable are given below:

□ The Water (Prevention and Control of Pollution) Act, 1974, this provides for the prevention and control of water pollution and the maintaining and restoring of wholesomeness of water. 'Pollution' means such contamination of water or such alteration of the physical, chemical or biological properties of water or such discharge of any sewage or trade effluent or of any other liquid, gaseous or solid substance into water (whether directly or indirectly) as may, or is likely to, create a nuisance or render such water harmful or injurious to public health or safety, or to domestic, commercial, industrial, agricultural or other legitimate uses, or to the life and health of animals or plants or of aquatic organisms.

□ The Air (Prevention and Control of Pollution) Act, 1981, this provides for prevention, control and abatement of air pollution. 'Air Pollution' means the presence in the atmosphere of any 'air pollutant', which means any solid, liquid or gaseous substance (including noise) present in the atmosphere in such concentration as may be or tend to be injurious to human beings or other living creatures or plants or property or environment.

□ The Environment (Protection) Act, 1986, this provides for the protection and improvement of environment and for matters connected therewith, and the prevention of hazards to human beings, other living creatures, plants and property. 'Environment' includes water, air and land and the inter-relationship which exists among and between water, air and land, and human beings, other living creatures, plants, micro-organism and property.

□ The Public Liability Insurance Act, 1991, This provides for public liability insurance for the purpose of providing immediate relief to the persons affected by accident occurring while handling hazardous substances and for matters connected herewith or incidental thereto. Hazardous substance means any substance or preparation which is defined as hazardous substance under the Environment (Protection) Act 1986, and exceeding such quantity as may be specified by notification by the Central Government.

16. The Works and Routine Maintenance to be completed by the Intended Completion Date

16.1 The Contractor may commence execution of the Works on the Start Date and shall carry out the Works and Routine Maintenance, if specified in the tender, in accordance with the Programme submitted by the Contractor, as updated with the approval of the Engineer, and complete them by the Intended Completion Date.

17. Approval by the Engineer

17.1 The Contractor shall submit Specifications and Drawings showing the proposed Temporary Works to the Engineer, who is to approve them if they comply with the Specifications and Drawings.

17.2 The Contractor shall be responsible for design and safety of Temporary Works.

17.3 The Engineer's approval shall not alter the Contractor's responsibility for design and safety of the Temporary Works.

17.4 The Contractor shall obtain approval of third parties to the design of the Temporary Works, where required.

17.5 All Drawings prepared by the Contractor for the execution of the temporary or permanent Works, are subject to prior approval by the Engineer before their use.

18. Safety

18.1 The Contractor shall be responsible for the safety of all activities on the Site. He shall comply with all applicable safety requirements and take care of safety of all persons entitled to be on the site and the works. He shall use reasonable efforts to keep the site and the works, both during construction and maintenance, clear of unnecessary obstruction so as to avoid danger to the persons and the users.

Workers employed on mixing asphaltic materials, cement and lime mortars shall be provided with protective footwear and protective goggles.

Stone breaker shall be provided with protective goggles and protective clothing and seated at sufficiently safe intervals.

The area should be barricaded or cordoned off by suitable means to avoid mishaps of any kind. Power warning signs should be displayed for the safety of the public whenever cleaning works are undertaken during night or day.

The workers engaged for cleaning the manholes/sewers should be properly trained before allowing working in the manhole.

18.2 Safety Programs:-

I. Have adequate safety supervision in place to ensure that safety programs set up by the firms/agencies are in compliance with prevalent laws and regulations.

II. Review safety programs developed by each of the trade firms, prepare and submit a comprehensive safety program.

III. Monitor day to day implementation of safety procedures.

18.3 First Aid Facilities: -

i. At every work place there shall be provided and maintained, so as to be easily accessible during working hours, first-aid boxes at the rate of not less than one box for 150 contract labour or part thereof ordinarily employed.

- ii. The first-aid box shall be distinctly marked with a red cross on white back ground.
- iii. Adequate arrangements shall be made for immediate re coupment of the equipment when necessary.
- iv. Nothing except the prescribed contents shall be kept in the First-aid box.
- v. The first-aid box shall be kept in charge of a responsible person who shall always be readily available during the working hours of the work place.
- vi. A person in charge of the First-aid box shall be a person trained in First-aid treatment, in the work places where the number of contract labour employed is 150 or more.

19. Discoveries

19.1 Anything of historical or other interest or of significant value unexpectedly discovered on the Site shall be the property of the Employer. The Contractor shall notify the Engineer of such discoveries and carry out the Engineer's instructions for dealing with them.

20. Possession of the Site

20.1 The Employer shall handover complete or part possession of the site to the Contractor 7 days in advance of construction programme. At the start of the work, the Employer shall handover the possession of atleast 75% of the site free of all encumbrances, the remaining 25 % of the possession as per contractor's construction programme.

21. Access to the Site

21.1 The Contractor shall allow access to the Site and to any place where work in connection with the Contract is being carried out, or is intended to be carried out to the Engineer and any person/persons/agency authorized by: a. The Engineer b. The Employer or authorized by the Employer.

22. Instructions

22.1 The Contractor shall carry out all instructions of the Engineer, which comply with the applicable laws where the Site is located.

22.2 The Contractor shall permit the appointed and/or authorized persons to inspect the Site and/or accounts and records of the Contractor and its subcontractors relating to the performance of the Contract, and to have such accounts and records audited by auditors appointed, if so required. The Contractor's attention is invited to Clause of 'Fraud and Corruption', which provides, inter alia, that acts intended to materially impede the exercise of the inspection and audit rights provided for under the Clause & constitute a obstructive practice subject to contract termination.

22.3 Engineer to have power to issue further drawings or instructions:

The Engineer shall have the power and authority from time to time and at all times to make and issue such further drawings and to give such further instructions and directions as may appear to him necessary or proper for the guidance of the contractor and the good and sufficient execution of the works according to terms of the specifications and Contractor shall receive, execute, obey and be bound by the same, according to the true intent and meaning thereof, as fully and effectually as though the same had accompanied or had been mentioned or referred to in the specification, and the Engineer may also alter or vary the levels or position of nature of works contemplated by the specifications, or may order any of the works contemplated thereby to be omitted, with or without the substitution of any other works in lieu thereof, or may order any work or any portion of work executed or partially executed, to be removed, changed or altered, added if needful, may order that other works shall be substituted instead thereof and difference of expense occasioned by any such diminution or alteration so ordered and directed shall be added to or deducted from the amount of this Contract, as provided under condition no.10(a) hereinafter.

No work which radically changes the original nature of the Contract shall be ordered by the Engineer and in the event of any deviation being ordered which in the opinion of the Contractor changes the original nature of Contract he shall nevertheless carry it out and disagreement as to the nature of the work and the rate to be paid therefore shall be resolved in accordance with condition no.13d.

The time for completion of the Works, shall be in even of any deviations resulting in additional cost over the contract price being ordered, be extended or reduced reasonably by the Engineer. The Engineer's decision in this case shall be final.

B. Time Control

23. Programme

23.1 Within the time stated in the Contract Data, the Contractor shall submit to the Engineer for approval a Programme, including Environment Management Plan showing the general methods, arrangements, order, and timing for all the activities in the Works, along with monthly cash flow forecasts for the construction of works.

After the completion of the construction works, the programme for the Routine Maintenance Work, showing the general methods, arrangements, order and timing for all the activities involved in the Routine Maintenance will also be submitted by the Contractor to the Engineer for approval if specified in the tender. The programme for Routine Maintenance will be submitted in each year for the period of Maintenance.

23.2 The Contractor shall submit the list of equipment and machinery being brought to site, the list of key personnel being deployed, the list of machinery/ equipments being

placed in field laboratory and the location of field laboratory along with the Programme. The Engineer shall cause these details to be verified at each appropriate stage of the programme.

23.3 An update of the Programme shall be a programme showing the actual progress achieved on each activity and the effect of the progress achieved on the timing of the remaining Works, including any changes to the sequence of the activities.

23.4 The Contractor shall submit to the Engineer for approval an updated Programme at intervals no longer than the period stated in the Contract Data. If the Contractor does not submit an updated Programme within this period, the Engineer may withhold the amount stated in the Contract Data from the next payment certificate and continue to withhold this amount until the next payment after the date on which the overdue Programme has been submitted.

23.5 The Engineer's approval of the Programme shall not alter the Contractor's obligations. The Contractor may revise the Programme and submit it to the Engineer again at any time. A revised Programme shall show the effect of Variations and Compensation Events.

24. Extension Of Time In Contracts :

Subject to any requirement in the contract as to completion of any portions or portions of the works before completion of the whole, the contractor shall fully and finally complete the whole of the works comprised in the contract (with such modifications as may be directed under conditions of this contract) by the date entered in the contract or extended date in terms of the following clauses:

a) Extension attributable to BMC

(i) Extension Due To Modification: If any modifications have been ordered which in the opinion of the Engineer have materially increased the magnitude of the work, then such extension of the contracted date of completion may be granted as shall appear to the Engineer to be reasonable in the circumstances, provided moreover that the Contractor shall be responsible for requesting such extension of the date as may be considered necessary as soon as the cause thereof shall arise and in any case should not be less than 30 days before the expiry of the date fixed for completion of the works.

(ii) Extension For Delay Due To BMC: In the event of any failure or delay by the BMC to hand over the Contractor possession of the lands necessary for the execution of the works or to give the necessary notice to commence the works or to provide the necessary drawings or instructions or any other delay caused by the BMC due to any other cause whatsoever, then such failure or delay shall in no way affect or vitiate the contract or alter the character thereof or entitle the contractor to damages or compensation therefore, but in any such

case, the BMC may grant such extension(s) of the completion date as may be considered reasonable.

Note: For extension of time period as governed in (i) and (ii) above, any modifications in design/drawings, specifications, quantities shall be needed to be justified with recorded reasons with approval of Ch.Eng. for not anticipating the same while preparing estimates and draft tender.

(b) Extension Of Time For Delay Due To Contractor : The time for the execution of the work or part of the works specified in the contract documents shall be deemed to be the essence of the contract and the works must be completed no later than the date(s) / the programme for completion of work as specified in the contract. If the contractor fails to complete the works within the time as specified in the contract for the reasons other than the reasons specified in above as (a.i) and (a.ii), the BMC may, if satisfied that the works can be completed by the contractor within reasonable short time thereafter, allow the contractor for further extension of time as the Engineer may decide. On such extension the BMC will be entitled without prejudice to any other right and remedy available on that behalf, to recover the compensation as governed by Clause 8(e) of GCC.

For the purpose of this Clause, the contract value of the works shall be taken as value of work as per contract agreement including any supplementary work order/contract agreement issued.

Further, competent authority while granting extension to the currency of contract under Clause (b) of as above may also consider levy of penalty, as deemed fit based on the merit of the case. Also, the reasons for granting extension shall be properly documented.

25. Delays Ordered by the Engineer

25.1 The Engineer may instruct the Contractor to delay the start or progress of any activity within the Works. Delay/delays totaling more than 30 days will require prior written approval of the DMC/AMC.

26. Management Meetings

26.1 The Engineer may require the Contractor to attend a management meeting. The business of a management meeting shall be to review the plans for progress of the Works.

26.2 The Engineer shall record the business of management meetings and provide copies of the record to those attending the meeting. The responsibility of the parties for actions to be taken shall be decided by the Engineer either at the management meeting or after the management meeting and stated in writing to all those who attended the meeting.

C. Quality Control

27.1. Work to be open to Inspection and Contractor or Responsible agent to be present

All works under or in course of execution or executed in pursuance of the contract shall at all times be open to the inspection and supervision of the Eng-in-charge and his subordinates and the contractor shall at all times during the usual working hours, at all other times, during the usual working hours and at all other times at which reasonable notice of the intention of the Eng-in-charge and his subordinates to visit the works shall have been given to the contractor, either himself be present to receive orders and instruction or have responsible agent duly accredited in writing present for that purpose. Order given to the contractors' duly authorized agent shall be considered to have the same force and effect as if they had been given to the contractor himself.

27.2. Notice To Be Given Before Work Is Covered Up The contractor shall give not less than ten days' notice in writing to the Eng-In-Charge or his subordinate in-charge of the work before covering up or otherwise placing beyond the reach of measurement any work in order that the same may be measured and correct dimension thereof taken before the same is so covered up or placed beyond the reach of measurements and shall not cover up or place beyond the reach of measurement any work without the consent in writing of the Eng-In-Charge or his subordinate in-charge of the work, and if any work shall be covered up or placed beyond the reach of measurement, without such notice having been given or consent obtained the same shall be uncovered at the contractors expenses, and in default thereof no payment or allowance shall be made for such work or for the materials with which the same was executed

27.3 Works to be executed in accordance with specifications / drawings / orders etc. :

The contractor shall execute the whole and every part of the work the most substantial and workman like manner and both has regards material and every other respect in strict accordance with specifications. The contractor shall also confirm exactly, fully and faithfully to the designs, drawings and instructions in writing relating to the work signed by the Engineer In-charge and lodged in his office and to which the contractor shall be entitled to have access for the purpose of inspection at such office, or on the site or work during office hours. The contractor shall be entitled to receive three sets of contract drawings and working drawings as well as one certified copy of the accepted tender along with the work order free of cost.

28. Identifying Defects

28.1 The Engineer shall check the Contractor's work and notify the Contractor of any Defects that are found. Such checking shall not affect the Contractor's responsibilities. The Engineer may instruct the Contractor to search for a Defect and to uncover and test any work that the Engineer considers may have a Defect.

28.2 The Contractor shall permit the Employer's technical person(s) to check the Contractor's work and notify the Engineer and Contractor if any defects that are found.

29. Tests

29.1 For carrying out mandatory tests as prescribed in the specifications, the Contractor shall establish field laboratory at the location decided by Engineer. The field laboratory will have minimum of equipments as specified in the Contract Data. The contractor shall be solely responsible for:

- a. Carrying out the mandatory tests prescribed in the Specifications, and
- b. For the correctness of the test results, whether preformed in his laboratory or elsewhere.

29.2 If the Engineer instructs the Contractor to carry out a test not specified in the Specification/ Quality Assurance Handbook to check whether any work has a Defect and the test shows that it does, the Contractor shall pay for the test and any samples. If there is no defect, the test shall be a compensation event.

When required by the Engineer-in-charge the contractor(s) shall supply for the purpose of testing samples of all materials proposed to be used in the works. Samples submitted either to govern bulk supplies or required for testing before use shall be in suitable packages to contain them and shall be provided free of charge by the contractor. The cost of testing shall be borne by the contractor even if the result of the sample confirm or do not confirm to the relevant BIS code specifications.

- i. All expenditure required to be incurred for taking the samples conveyance, packing shall be borne by the contractor himself.
- ii. The failed material shall be removed from the site by the contractor at his own cost within a week time of written order of the Engineer-in-charge.

30 Correction of Defects noticed during the Defects Liability Period. During the Defects Liability Period (DLP) , the completed work shall be periodically inspected by the site staff along with the contractor and defects noticed, if any shall be got rectified immediately from the contractor as per provision of contract. The above compliance report shall be mandatory prerequisite before releasing the deposite/retention money of the work . The concern Account Officer shall confirm in this regards. Alternatively, the inspection of DLP roads during DLP period can also be entrusted to contractor's engineer and modality can be decided by the user department and accordingly, there can be tender condition.

30.1 (a) The Engineer shall give notice to the Contractor of any Defects before the end of the Defects Liability Period, which begins at Completion and ends after three years. The Defects Liability Period shall be extended for as long as Defects remain to be corrected.

(b) Every time notice of Defect/Defects is given, the Contractor shall correct the notified Defect/Defects within the duration of time specified by the Engineer's notice.

(c) The Engineer may issue notice to the Contractor to carry out removal of defects or deficiencies, if any, noticed in his inspection, or brought to his notice. The Contractor shall remove the defects and deficiencies within the period specified in the notice and submit to the Engineer a compliance report.

31. Uncorrected Defects and Deficiencies

31.1 If the Contractor has not corrected a Defect pertaining to the Defect Liability Period under clause and deficiencies in maintenance, to the satisfaction of the Engineer, within the time specified in the Engineer's notice, the Engineer will assess the cost of having the Defect or deficiency corrected, and the Contractor shall pay this amount, on correction of the Defect or deficiency by another agency.

D. Cost Control

32 Variations

The Engineer shall having regard to the scope of the works and the sanctioned estimated cost, have power to order, in writing, Variation within the scope of the works he considers necessary or advisable during the progress of the works. Such variation shall form part of the contract and the contractor shall carry them out and include them in updated programmes produced by the contractor. Oral orders of the engineer for variations, unless followed by written confirmation, shall not be taken into account.

33 Payment for Variations

33.1 If rates for variation items are specified in the bill of quantities, the contractor shall carry out such work at the same time.

33.2 The rate for extra / excess shall be governed by clause 10.A of Standard General Conditions of Contract.

34 Cash Flow Forecasts

When the Programme is updated, the Contractor shall provide the Engineer with an updated cash flow forecast.

35 Payment Certificates

The payment to the Contractor will be as follows for construction work:

(a) A bill shall be submitted by the Contractor monthly or before the date fixed by the Engineer In-charge for all works executed in the previous month, and the Engineer In-charge shall take or cause to be taken requisite measurement for the purpose of having the same verified and the claim, so far as it is admissible, shall be adjusted, if possible, within 10 days from the presentation of the bill. If the contractor does not submit the bill within the time fixed as aforesaid, the Engineer In-charge may depute a subordinate to measure up the said work in the presence of the contractor or his duly authorized agent whose

counter signature to the measurement list shall be sufficient warrant, and Engineer In-Charge may prepare a bill from such list which shall be binding on the contractor in all respects.

(b) The Engineer shall check the Contractor's fortnightly/monthly statement within 14 days and certify the amount to be paid to the Contractor.

(c) The value of work executed shall be determined, based on measurements by the Engineer.

(d) The value of work executed shall comprise the value of the quantities of the items in the Bill of Quantities completed.

(e) The value of work executed shall also include the valuation of Variations and Compensation Events.

(f) The Engineer may exclude any item certified in a previous certificate or reduce the proportion of any item previously certified in any certificate in the light of later information.

(g) The contractor shall submit all bills on the printed forms at the office of Engineer In-charge. The charges to be made in the bills shall always be entered at the rates specified in tender.

36. Payments

36.1 Payments shall be adjusted for deductions for advance payments, retention, security deposit, other recoveries in terms of the Contract and taxes at source, as applicable under the law. The Employer shall pay the Contractor the amounts certified by the Engineer within 15 days of the date of each certificate.

36.2 All sums payable by a contractor by way of compensation under any of these conditions, shall be considered as a reasonable compensation to be applied to the use of BMC without reference to the actual loss or damage sustained and whether any damage has or has not been sustained.

36.3 No payment shall be made for any work estimated to cost less than Rupees One Thousand till after the whole of work shall have been completed and the certificate of completion given. But in the case of works estimated to cost more than Rs. One Thousand, the contractor shall on submitting a monthly bill therefore be entitled to receive payment proportionate to the part of the work than approved and passed by the Engineer In-charge, whose certificate of such approval and passing of the sum so payable shall be final and conclusive against the contractor. All such intermediate payments shall be regarded as payments by way of advance against the final payments only and not as payments for work actual done and completed and shall not preclude the Engineer In-charge from requiring any bad, unsound, imperfect or unskillful work to be removed or taken away and reconstructed or re-erected nor shall any such payment be considered as an admission of the due performance of the contract or any part thereof in any respect or the offering of any

claim not shall it conclude, determine or effect in any other way, the powers of the Engineer In-charge as to the final settlement and adjustment of the accounts or otherwise, or in any other way vary or effect the contract. The final bill shall be submitted by the Contractor within one month of the date fixed for the completion of the work otherwise the Engineer In-charge's certificate of the measurements and of the total amount payable for the work shall be final and binding on all parties.

37. The Contractor shall not be entitled to compensation to the extent that the Employer's interests are adversely affected by the Contractor for not having given early warning or not having cooperated with the Engineer.

38. Tax

The tenderer shall quote inclusive of all taxes other than GST (Excluding GST), Levies, Duties, Cess etc as applicable at the time of bid submission. GST as applicable shall be paid separately on submission of bills/invoice.

Input Tax Credit of GST as available with the bidder will not be claimed separately by BMC.

However, while quoting the rates benefit of Input Tax Credit or Exemptions shall be passed on to the BMC by way of equivalent reduction in quoted price.

“Chapter XXI- Miscellaneous, section 171(1) of GST Act, 2017 governs the `Anti-Profitteering Measures` (APM)As per the provision of this section, ‘Any reduction in rate of tax on any supply of goods or services or the benefit of input tax credit shall be passed on to the recipient by way of commensurate reduction in prices. ‘Accordingly, the contractor should pass on the complete benefit accruing to him on account of reduced tax rate or additional input tax credit to BMC. Further, all the provisions of GST Act will be applicable to the tenderer.

If contract cost exceeds 2,50,000.00 (Excluding GST), 2% GST TDS (1% CGST + 1% SGST or 2% IGST) will be deducted at source as per circular CA(Treasury) /Cash / City/ 20 dtd. 05.10.2018

39. Currencies

All payments will be made in Indian Rupees.

40. Liquidated Damages

Both, the Contractor and the Employer have agreed that it is not feasible to precisely estimate the amount of losses due to delay in completion of works and the losses to the public and the economy, therefore, both the parties have agreed that the Contractor shall pay liquidated damages to the Employer and not by way of penalty, at the rate per week or part thereof stated in the Contract Data for the period that the Completion Date is later than the Intended Completion Date. Liquidated damages at the same rates shall be

withheld if the Contractor fails to achieve the milestones prescribed in the Contract Data. However, in case the Contractor achieves the next milestone, the amount of the liquidated damages already withheld shall be restored to the Contractor by adjustment in the next payment certificate. The Employer and the contractor have agreed that this is a reasonable agreed amount of liquidated damage. The Employer may deduct liquidated damages from payments due to the Contractor. Payment of liquidated damages shall not affect the Contractor's other liabilities.

41. Cost of Repairs

Loss or damage to the Works or Materials to be incorporated in the Works between the Start Date and the end of the Defects Correction periods shall be remedied by the Contractor at his cost if the loss or damage arises from the Contractor's acts or omissions.

E. Finishing the Contract

42. Completion of Construction and Maintenance

42.1 The Contractor shall request the Engineer to issue a certificate of completion of the construction of the works, and the Engineer will do so upon deciding that the works is completed. This shall be governed as per clause no.8(g) of Standard General Conditions of Contract.

43. Taking Over

43.1 The Employer shall take over the works within seven days of the Engineer issuing a certificate of completion of works. The Contractor shall continue to remain responsible for its routine maintenance during the maintenance period if specified in the contract.

44. Final Account

Final joint measurement along with the representatives of the contractor should be taken recorded and signed by the Contractors. Contractors should submit the final bill within 1 month of physical completion of the work.

If the contractor fails to submit the final bill within 1 month, the BMC staff will prepare the final bill based on the joint measurement within next 3 months.

Engineer's decision shall be final in respect of claims for defect and pending claims against contractors.

No further claims should be made by the Contractor after submission of the final bill and these shall be deemed to have been waived and extinguished. Payment of those items of the bills in respect of which there is no dispute and of items in dispute, for quantities and rates as approved by the Commissioner shall be made within a reasonable period as may be necessary for the purpose of verification etc.

After payment of the final bill as aforesaid has been made, the contractor may, if he so desires, reconsider his position in respect of a disputed portion of the final bills and if he

fails to do so within 84 days, his disputed claim shall be dealt with as provided in the contract. A percentage of the retention money, over and above the actual retention money as indicated below shall be held back from payments till the finalization of final bill to be submitted as per above and will be paid within 30 days of acceptance of the final bill.

Sr.No.	Amount of Contract Cost	Minimum Payable Amount in final bill
1	Upto Rs.5 Crs.	Rs.10 Lacs or final bill whichever is more
2	Upto Rs.25 Crs.	Rs.1 Crore or final bill amount whichever is more
3	Upto Rs. 50 Crs.	Rs.2 Crores or final bill amount whichever is more

The contractor have to submit the bill for the work carried out within 15 days from the date of completion of the work to the respective executing department. If the contractor fails to submit their bills to concerned executing department, penalty or action as shown below will be taken for each delayed bill:-

After 15 days from the date of completion/running bill upto certain date, upto next 15 days i.e. upto 30 days	Equal to 5% of bill amount
Next 15 days upto 45 days from the date of completion/running bill upto specified date	Equal to 10% of bill amount
If not submitted within 45 days from the date of completion/ R.A. bill	Bill will not be admitted for payment.

45. Operating and Maintenance Manuals

45.1 If "as built" Drawings and/or operating and maintenance manuals are required, the Contractor shall supply them by the dates stated in the Contract Data.

45.2 If the Contractor does not supply the Drawings and/or manuals by the dates stated in the Contract Data, or they do not receive the Engineer's approval, the Engineer shall withhold the amount stated in the Contract Data from payments due to the Contractor.

46. Termination

46.1 The Employer or the Contractor may terminate the Contract if the other party causes a fundamental breach of the Contract.

46.2 Fundamental breaches of Contract shall include, but shall not be limited to, the following:

a) The Contractor stops work for 30 days when no stoppage of work is shown on the current Programme and the stoppage has not been authorized by the Engineer;

- b) The Contractor is declared as bankrupt or goes into liquidation other than for approved reconstruction or amalgamation;
- c) the Engineer gives Notice that failure to correct a particular Defect is a fundamental breach of Contract and the Contractor fails to correct it within a reasonable period of time determined by the Engineer;
- d) The Contractor does not maintain a Security, which is required; e) the Contractor has delayed the completion of the Works by the number of days for which the maximum amount of liquidated damages can be paid, as defined in relevant clause.
- f) The Contractor fails to provide insurance cover as required under relevant clause
- g) If the Contractor, in the judgment of the Employer, has engaged in the corrupt or fraudulent practices as defined in GCC in competing for or in executing the Contract.
- h) If the Contractor fails to set up a field laboratory with the prescribed equipment, within the period specified in the Contract Data; and
- i) Any other fundamental breaches as specified in the Contract Data.
- j) If the Contractor fails to deploy machinery and equipment or personnel as specified in the Contract Data at the appropriate time.

46.3 When either party to the contract gives notice of a breach of contract to the Engineer for a cause other than those listed above, the Engineer shall decide whether the breach is fundamental or not.

46.4 Notwithstanding the above, the Employer may terminate the Contract for convenience.

46.5 If the Contract is terminated, the Contractor shall stop work immediately, make the Site safe and secure, and leave the Site as soon as reasonably possible.

47. Payment upon Termination

47.1 If the Contract is terminated because of a fundamental breach of Contract by the Contractor, the Engineer shall issue a certificate for value of the work done and materials ordered less liquidated damages, if any, less advance payments received up to the date of the issue of the certificate and less the percentage to apply to the value of the work not completed, as indicated in the Contract Data. If the total amount due to the Employer exceeds any payment due to the Contractor, the difference shall be recovered from the security deposit, and performance security. If any amount is still left un-recovered it will be a debt due from the Contractor to the Employer

47.2 If the Contract is terminated at the Employer's convenience, the Engineer shall issue a certificate for the value of the work done, the reasonable cost of removal of Equipment, repatriation of the Contractor's personnel employed solely on the Works, and the Contractor's costs of protecting and securing the Works and less advance payments

received up to the date of the certificate, less other recoveries due in terms of the Contract, and less taxes due to be deducted at source as per applicable law.

48. Property

All Materials on the Site, Plant, Equipment, Temporary Works, and Works shall be deemed to be the property of the Employer for use for completing balance construction work if the Contract is terminated because of the Contractor's default, till the Works is completed after which it will be transferred to the Contractor and credit, if any, given for its use.

49. Release from Performance

If the Contract is frustrated by the outbreak of war or by any other event entirely outside the control of the Employer or the Contractor, the Engineer shall certify that the Contract has been frustrated. The Contractor shall make the Site safe and stop work as quickly as possible after receiving this certificate and shall be paid for all work carried out before receiving it and for any work carried out afterwards to which a commitment was made.

A) Other Conditions of Contract

50. Labour

50.1 The Contractor shall, unless otherwise provided in the Contract, make his own arrangements for the engagement of all staff and labour, local or other, and for their payment, housing, feeding and transport.

50.2 The Contractor shall, if required by the Engineer, deliver to the Engineer a return in detail, in such form and at such intervals as the Engineer may prescribe, showing the staff and the number of the several classes of labour from time to time employed by the Contractor on the Site and such other information as the Engineer may require.

51. Compliance with Labour Regulations

(a) During continuance of the Contract, the Contractor and his sub-Contractors shall abide at all times by all existing labour enactments and rules made there under, regulations, notifications and bye laws of the State or Central Government or local authority and any other labour law (including rules), regulations, bye laws that may be passed or notification that may be issued under any labour law in future either by the State or the Central Government or the local authority.

(b) Furthermore, the Contractor shall keep the Employer indemnified in case any action is taken against the Employer by the competent authority on account of contravention of any of the provisions of any Act or rules made there under, regulations or notifications including amendments. If the Employer is caused to pay or reimburse, such amounts as may be necessary to cause or observe, or for non-observance of the provisions stipulated in the notifications/bye laws/Acts/Rules/regulations including amendments, if any, on the part of

the Contractor, the Engineer/Employer shall have the right to deduct any money due to the Contractor including his amount of performance guarantee. The Employer/Engineer shall also have right to recover from the Contractor any sum required or estimated to be required for making good the loss or damage suffered by the Employer.

(c) The Contractor shall require his employees to obey all applicable laws, including those concerning safety at work.

(d) The employees of the Contractor and the Sub-Contractor in no case shall be treated as the employees of the Employer at any point of time.

52. Drawings and Photographs of the Works

52.1 The Contractor shall do photography/video photography of the site firstly before the start of the work, secondly mid-way in the execution of different stages of work as required by Engineer In-charge and lastly after the completion of the work. No separate payment will be made to the Contractor for this.

52.2 The Contractor shall not disclose details of Drawings furnished to him and works on which he is engaged without the prior approval of the Engineer in writing. No photograph of the works or any part thereof or plant employed thereon, except those permitted under above clause, shall be taken or permitted by the Contractor to be taken by any of his employees or any employees of his sub-Contractors without the prior approval of the Engineer in writing. No photographs/ Video photography shall be published or otherwise circulated without the approval of the Engineer in writing.

53. The Apprentices Act, 1961

The Contractor shall duly comply with the provisions of the Apprentices Act 1961 (III of 1961), the rules made there under and the orders that may be issued from time to time under the said Act and the said Rules and on his failure or neglect to do so, he shall be subject to all liabilities and penalties provided by the said Act and said Rules.

54 Contract Document

The documents forming the contract are to be taken as mutually explanatory of one another. Unless otherwise provided in the contract, the priority of the documents forming the contract shall be, as follows:

- 1) Contract Agreement (if completed)
- 2) The letter of Acceptance
- 3) The Bid:
- 4) Addendum to Bid; if any
- 5) Tender Document
- 6) The Bill of Quantities:
- 7) The Specification:

8) Detailed Engineering Drawings

9) Standard General Conditions of Contracts (GCC)

10) All correspondence documents between bidder/contractor and BMC.

55 Conflict of Interest

The Applicant shall not have a conflict of interest (the "Conflict of Interest") that affects the Bidding Process. Any Applicant found to have a Conflict of Interest shall be disqualified. An Applicant shall be deemed to have a Conflict of Interest affecting the Bidding Process, if

1. A constituent of such Applicant is also a constituent of another Applicant; or
2. Such Applicant has the same legal representative for purposes of this Application as any other Applicant; or
3. Such Applicant, or any Associate thereof has a relationship with another Applicant, or any Associate thereof, directly or through common third party/ parties, that puts either or both of them in a position to have access to each other's information about, or to influence the Application of either or each other; or
4. The Applicant shall be liable for disqualification if any legal, financial or technical adviser of the Authority in relation to the Project is engaged by the Applicant, its Member or any Associate thereof, as the case may be, in any manner for matters related to or incidental to the Project. For the avoidance of doubt, this disqualification shall not apply where such adviser was engaged by the Applicant, its Member or Associate in the past but its assignment expired or was terminated 6 (six) months prior to the date of issue of this TENDER. Nor will this disqualification apply where such adviser is engaged after a period of 3(three) years from the date of commercial operation of the Project.

56. Applications and costs thereof

No Applicant shall submit more than one Application for the Project. An applicant applying individually shall not be entitled to submit another application either individually. The Applicant shall be responsible for all of the costs associated with the preparation of their Applications and their participation in the Bid Process. The Authority will not be responsible or in any way liable for such costs, regardless of the conduct or outcome of the Bidding Process.

57. Acknowledgment by Applicant

It shall be deemed that by submitting the Application, the Applicant has:

- a. made a complete and careful examination of the tender;
 - b. received all relevant information requested from the Authority;
 - c. accepted the risk of inadequacy, error or mistake in the information provided in the tender or furnished by or on behalf of the Authority relating to any of the matters referred;
- and

d. Agreed to be bound by the undertakings provided by it under and in terms hereof.

“The Authority” shall not be liable for any omission, mistake or error in respect of any of the above or on account of any matter or thing arising out of or concerning or relating to the TENDER or the Bidding Process, including any error or mistake therein or in any information or data given by the Authority.

58. Right to accept or reject any or all Applications/ Bids

Notwithstanding anything contained in this TENDER, “The Authority” reserves the right to accept or reject any Application and to annul the Bidding Process and reject all Applications/ Bids, at any time without any liability or any obligation for such acceptance, rejection or annulment, and without assigning any reasons therefore. In the event that the Authority rejects or annuls all the Bids, it may, in its discretion, invite all eligible Bidders to submit fresh Bids hereunder.

“The Authority” reserves the right to reject any Application and/ or Bid if:

(a) at any time, a material misrepresentation is made or uncovered, or

(b) the Applicant does not provide, within the time specified by the Authority, the supplemental information sought by the Authority for evaluation of the Application. In case it is found during the evaluation or at any time before signing of the Agreement or after its execution and during the period of subsistence thereof including the concession thereby granted by “The Authority”, that one or more of the pre-qualification conditions have not been met by the Applicant, or the Applicant has made material misrepresentation or has given any materially incorrect or false information, the Applicant shall be disqualified forthwith if not yet appointed as the Successful Bidder either by issue of the LOA (Letter of Approval) or entering into of the Agreement, and if the Applicant has already been issued the LOA or has entered into the Concession Agreement, as the case may be, the same shall, notwithstanding anything to the contrary contained therein or in this TENDER, be liable to be terminated, by a communication in writing by “The Authority” to the Applicant, without the Authority being liable in any manner whatsoever to the Applicant and without prejudice to any other right or remedy which the Authority may have under this TENDER, the Bidding Documents, the Concession Agreement or under applicable law.

“The Authority” reserves the right to verify all statements, information and documents submitted by the Applicant in response to the TENDER. Any such verification or lack of such verification by the Authority shall not relieve the Applicant of its obligations or liabilities hereunder nor will it affect any rights of the Authority there under.

59 The bid shall be rejected if the bidder -

a. Stipulates the validity period less than 180 days.

b. Stipulates own condition/conditions.

c. Does not fill and (digital) sign undertaking forms, which are incorporated, in the document.

60 Clarifications

Applicants requiring any clarification on the tender may notify “the Authority” in writing or by fax or e-mail. They should send in their queries before the date specified in the header data. “The Authority” shall Endeavor to respond to the queries within the period specified therein. The responses will be sent by fax and/or e-mail. The Authority will forward all the queries and its responses thereto, to all purchasers of the TENDER without identifying the source of queries.

“The Authority” shall Endeavor to respond to the questions raised or clarifications sought by the Applicants. However, the Authority reserves the right not to respond to any question or provide any clarification, in its sole discretion, and nothing in this Clause shall be taken or read as compelling or requiring the Authority to respond to any question or to provide any clarification, but not later than the date provided in header data.

“The Authority” may also on its own motion, if deemed necessary, issue interpretations and clarifications to all Applicants. All clarifications and interpretations issued by the Authority shall be deemed to be part of the tender. Verbal clarifications and information given by Authority or its employees or representatives shall not in any way or manner be binding on the Authority.

61 Amendment of tender

At any time prior to the deadline for submission of Application, the Authority may, for any reason, whether at its own initiative or in response to clarifications requested by an Applicant, modify the tender by the issuance of Addendum.

Any Addendum thus issued will be sent in writing/ Fax/ Email to all those who have purchased the tender.

In order to afford the Applicants a reasonable time for taking an Addendum into account, or for any other reason, the Authority may, in its sole discretion, extend the Application Due Date.

Preparation and Submission of Application

62 Language

The Application and all related correspondence and documents in relation to the Bidding Process shall be in English language. Supporting documents and printed literature

furnished by the Applicant with the Application may be in any other language provided that they are accompanied by translations of all the pertinent passages in the English language, duly authenticated and certified by the Applicant. Supporting materials, which are not translated into English, may not be considered. For the purpose of interpretation and evaluation of the Application, the English language translation shall prevail.

63 Format and signing of Application

The Applicant shall provide all the information sought under this TENDER. The Authority will evaluate only those Applications that are received in the required formats and complete in all respects. Incomplete and /or conditional Applications shall be liable to rejection.

The Applicant will upload bid in One Folder in electronic form which shall contain the scanned certified copies of the documents given below and the documents uploaded has to be digitally signed by the bidder. These copies shall be certified by Practicing Notary approved by the Govt. of Maharashtra or Govt. of India with his stamp, clearly stating his name & registration number, except where original documents are demanded

64 Marking of Applications

The Applicant shall submit the Application in the format specified at Appendix-I, together with the documents, upload in folder as "VENDOR" together with their respective enclosures

Applications submitted by fax, telex, telegram shall not be entertained and shall be rejected outright.

65 Late Applications

Applications received by the Authority after the specified time on the Application Due Date shall not be eligible for consideration and shall be summarily rejected.

66 Confidentiality

Information relating to the examination, clarification, evaluation, and recommendation for the short-listed qualified Applicants shall not be disclosed to any person who is not officially concerned with the process or is not a retained professional advisor advising the Authority in relation to or matters arising out of, or concerning the Bidding Process. The Authority will treat all information, submitted as part of Application, in confidence and will require all those who have access to such material to treat the same in confidence. The Authority may not divulge any such information unless it is directed to do so by any statutory entity that has the power under law to require its disclosure or is to enforce or assert any right or privilege of the statutory entity and/ or the Authority or as may be required by law or in connection with any legal process.

67 Clarification of Financial Bids

To assist in the examination, evaluation and comparison of Bids, the Engineer may, at his discretion, ask any bidder for clarification of his Bid, including breakdown of unit rates. The request for clarification and the response shall be in writing or by post/facsimile/e-mail. No Bidder shall contact the Engineer on any matter relating to his bid from the time of the bid opening to the time the contract is awarded. Any effort by the Bidder to influence the Engineer in the Engineer's bid evaluation, bid comparison or contract award decisions may result in the rejection of the Bidder's bid.

68 Inspection of site and sufficiency of tender:

1. The Contractor shall inspect and examine the site and its surrounding and shall satisfy himself before submitting his tender as to the nature of the ground and subsoil (so far as is practicable), the form and nature of the site, the quantities and nature of the work and materials necessary for the completion of the works and means of access to the site, the accommodation he may require and in general shall himself obtain all necessary information as to risk, contingencies and other circumstances which may influence or affect his tender. He shall also take into consideration the hydrological and climatic conditions.
2. The Employer may make available to the Contractor data on hydrological and sub-surface conditions as obtained by or on his behalf from investigations relevant to the works but the Contractor shall be responsible for his own interpretation thereof. The contractor shall engage his investigating agency with prior approval of the Engineer from the approved list of such agencies by BMC or Govt. at his cost initially before commencing actual work and which shall be reimbursed immediately subject to satisfaction of the Engineer for faithful compliance and submission of required data regarding such investigation within specified time.
3. The Contractor shall be deemed to have satisfied himself before tendering as to the correctness and sufficiency of his tender for the works and of the rates and prices quoted in the schedule of works / items / quantities, or in Bill of Quantities, which rates and prices shall, except as otherwise provided cover all his obligations under the Contract and all matters and things necessary for proper completion and maintenance of the works. No extra charges consequent on any misunderstanding.
4. Not Foreseeable Physical Obstructions or Conditions: If, however, during the execution of the Works the Contractor encounters physical obstructions or physical conditions, other than climatic conditions on the Site, which obstructions or conditions were, in his opinion, not foreseeable by an experienced contractor, the Contractor shall forthwith give notice thereof to the Engineer. On receipt of such notice, the Engineer shall, if in his opinion such

obstructions or conditions could not have been reasonably foreseen by an experienced contractor, after due consultation with the Contractor, determine:

- any extension of time to which the Contractor is entitled and
- the amount of any costs which may have been incurred by the Contractor by reason of such obstructions or conditions having been encountered, which shall be added to the Contract Price.
- and shall notify the Contractor accordingly. Such determination shall take account of any instruction which the Engineer may issue to the Contractor in connection therewith, and any proper and reasonable measures acceptable to the Engineer which the Contractor may take in the absence of specific instructions from the Engineer. However such costing shall be got approved by the competent authority as governed vide rules prevailing with authority.

6. Contractor's office near works: The Contractor shall have an office near the works at which notice from the Commissioner or the Engineer may be served and shall, between the hours of sunrise and sunset on all working days, have a clerk or some other authorized person always present at such office upon whom such notices may be served and service of any notices left with such clerk or other authorized person or at such office shall be deemed good service upon the Contractor and such offices shall have pre-requisite facilities for e-governance.

69 Official Secrecy:

The Contractor shall of all the persons employed in any works in connection with the contract that the India Official Secrets Act 1923 (XIX of 1923) applies to them and will continue to apply even after execution of the said works and they will not disclose any information regarding this contract to any third party. The contractor shall also bring into notice that, any information found to be leaked out or disclosed the concern person as well as the Contractor will be liable for penal action; further the Corporation will be at liberty to terminate the contract without notice.

70 Subsequent Legislation:

If on the day of submission of bids for the contract, there occur changes to any National or State stature, Ordinance, decree or other law or any regulation or By-laws or any local or other duly constituted authority or the introduction of any such National or State Statute, Ordinance, decree or by which causes additional or reduced cost to the Contractor, such additional or reduced cost shall, after due consultation with the Contractor, be determined by the concerned Engineering Department of BMC and shall be added to or deducted from the Contract Price with prior approval of competent authority and the concerned

Engineering Department shall notify the Contractor accordingly with a copy to the Employer. BMC reserve the right to take decision in respect of addition/reduction of cost in contract.

71 Patent, Right and Royalties:

The contractor shall save harmless and indemnify the Corporation from and against all claims and proceedings for or on account of infringement of any Patent rights, design trademark or name of other protected rights in respect of any constructional plant, machine work, or material used for or in connection with the Works or any of them and from and against all claims, proceedings, damages, costs, charges and expenses whatsoever in respect thereof or in relation thereto. Except where otherwise specified, the contractor shall pay all tonnage and other royalties, rent and other payments or compensation, if any, for getting stone, sand, gravel, clay or other materials required for the works or any of them.

72 Payments, Tax and Claims:

The limit for unforeseen claims Under no circumstances whatever the contractor shall be entitled to any compensation from BMC on any account unless the contractor shall have submitted a claim in writing to the Engineer-in-charge within 1 month of the case of such claim occurring.

No interest for delayed payments due to disputes, etc.:

It is agreed that the BRIHANMUMBAI MUNICIPAL CORPORATION or its Engineer or Officer shall not be liable to pay any interest or damage with respect of any moneys or balance which may be in its or its Engineer's or officer's hands owing to any dispute or difference or claim or misunderstanding between the Municipal Corporation of Greater Bombay or its Engineer or Officer on the one hand and the contractor on the other, or with respect to any delay on the part of the Municipal Corporation of Greater Bombay or its Engineer or Officers in making periodical or final payments or in any other respect whatever.

73 Settlement of Disputes:

Termination of contract for death

If the Contractor is an individual or a proprietary concern and the individual or the proprietor dies and if the Contractor is a partnership concern and one of the legal representative of the individual Contractor or the proprietor of the proprietary concern and in case of partnership, the surviving partners, are capable of carrying out and completing the contract, the Commissioner shall be entitled to cancel the contract as to its uncompleted part without the Corporation being in any way liable to payment of any compensation to the estate of the deceased Contractor and or to the surviving partners of

the Contractor's firm on account of the cancellation of the contract. The decision of the Commissioner that the legal representative of the deceased Contractor or surviving partners of the Contractor's firm cannot carry out and complete the contract shall be final and binding on the parties. In the event of such cancellation the Commissioner shall not hold estate of the deceased Contractor and or surviving partners of the Contractor's firm liable in damages for not completing the contract.

□ Settlement of Disputes:

If any dispute or differences of any kind whatsoever other than those in respect of which, the decision of any person is, by the Contract, expressed to be final and binding) shall arise between the Employer and the Contractor or the Engineer and the Contractor in connection with or arising out of the Contract or carrying out of the Works (Whether during the progress of the Works or after their completion and whether before or after the termination, abandonment or breach of the Contract) it, the aggrieved party may refer such dispute within a period of 7 days to the concerned Addl. Municipal Commissioner who shall constitute a committee comprising of three officers i.e. concerned Deputy Municipal Commissioner or Director (ES&P), Chief Engineer other than the Engineer of the Contract and concerned Chief Accountant. The Committee shall give decision in writing within 60 days. Appeal on the Order of the Committee may be referred to the Municipal Commissioner within 7 days. Thereafter the Municipal Commissioner shall constitute a Committee comprising of three Addl. Municipal Commissioners including Addl. Municipal Commissioner in charge of Finance Department. The Municipal Commissioner within a period of 90 days after being requested to do so shall give written notice of committee's decision to the Contractor. Save as herein provided such decision in respect of every matter so referred shall be final and binding upon both parties until the completion of the works, and shall forthwith be given effect to by the Contractor who shall proceed with the works with due diligence, whether he requires arbitration as hereinafter provided or not. If the Commissioner has given written notice of the decision to the Contractor and no Claim to arbitration has been communicated within a period of 90 days from receipt of such notice the said decision shall remain final and binding upon the Contractor.

74 Arbitration and Jurisdiction:

If the Commissioner shall fail to give notice of the decision as aforesaid within a period of 90 days after being requested as aforesaid, or if the Contractor be dissatisfied with any such decision, then and in any such case the Contractor may within 90 days after receiving notice of such decision or within 90 days after the expirations of the first named period of 90 days (as the case may be) require that the matter or matters in dispute be referred to

arbitration as hereinafter provided. All disputes or differences in respect of which the decision (if any) of the Commissioner has not become final and binding as aforesaid shall be finally settled by

Arbitration as follows:

Arbitration shall be effected by a single arbitrator agreed upon the parties. The arbitration shall be conducted in accordance with the provisions of the Arbitration Act, 1996 or any statutory modifications thereof, and shall be held at such place and time within the limits of Brihanmumbai as the arbitrator may determine. The decision of the arbitrator shall be final and binding upon the parties hereto and the expense of the arbitration shall be paid as may be determined by the arbitrator. Performance under the Contract shall, if reasonably be possible, continued during the arbitration proceedings and payment due to the Contractor by the Employer shall not be withheld unless they are the subject matter of arbitration proceedings. The said arbitrator shall have full power to open up, review and revise any decision, opinion, direction, certification or valuation of the Commissioner and neither party shall be limited in the proceedings before such arbitrator to the evidence or arguments put before the Commissioner for the purpose of obtaining his said decision. No decision given by the Commissioner in accordance with the foregoing provisions shall disqualify him from being called as a witness and giving evidence before the arbitrator on any matters whatsoever relevant to the disputes or difference referred to the arbitrator as aforesaid. All awards shall be in writing and for claims equivalent to 5,00,000 or more such awards shall state reasons for amounts awarded. The expenditure of arbitration shall be paid as may be determined by arbitrator.

In case of any claim, dispute or difference arising in respect of a contract, the cause of action thereof shall be deemed to have arisen in Mumbai and all legal proceedings in respect of any claim, dispute or difference shall be instituted in a competent court in the City of Mumbai only.

75 Copyright:

The copyright of all drawings and other documents provided by the Contractor under the contract shall remain vested in the Contractor or his sub-contractors as the case may be the employer shall have a license to use such drawings and other documents in connection with the design, construction, operation, maintenance of the works. At any time the Employer shall have further license without additional payment to the Contractor to use any such drawings or documents for the purpose of making any improvement of the works or enlargement or duplication of any part thereof, provided that such improvement, enlargement, or duplication by itself or in conjunction with any other improvements,

enlargements or duplications already made in accordance with the further license does not result in the duplication of the whole works.

76. Receipts to be signed in firm's name by any one of the partners:

Every receipt for money which may become payable or for any security which may become transferable to the Contractor under these present shall, if signed in the partnership name by any one of the partners, be a good and sufficient discharge to the Commissioner and Municipal Corporation in respect of the money or security purporting to be acknowledged thereby, and in the event of death of any of the partners during the pendency of this contract, it is hereby expressly agreed that every receipt by any one of the surviving partners shall, if so signed as aforesaid, be good and sufficient discharge as aforesaid provided that nothing in this clause contained shall be deemed to prejudice or effect any claim which the Commissioner or the Corporation may hereafter have against the legal representatives of any partners so dying or in respect of any breach of any of the conditions thereof, provided also that nothing in this clause contained shall be deemed prejudicial or affect the respective rights or obligations of the Contractors and of the legal representatives of any deceased Contractors interest.

77 Proprietary data

All documents and other information supplied by the Authority or submitted by an Applicant to the Authority shall remain or become the property of the Authority. Applicants are to treat all information as strictly confidential and shall not use it for any purpose other than for preparation and submission of their Application. The Authority will not return any Application or any information provided along therewith.

78 Correspondence with the Applicant

Save and except as provided in this TENDER, the Authority shall not entertain any correspondence with any Applicant in relation to the acceptance or rejection of any Application.

79 Price Variation Clause: No price variations shall be made applicable for contracts upto 12 months.

80. Maximum Price Variation : N.A. as per clause no. 79 above.

81. Payment: (As stated in section 10: Specifications)

82 Banning/De-Registration of Agencies of Construction works in BMC

□ The regulations regarding Demotion/ Suspension Banning for specific period or permanently / De-Registration shall be governed as per the respective condition in Contractor Registration Rules of BMC.

83. JOINT VENTURE

Joint Venture is not allowed for this Project being the estimated cost of tender is not more than 100 crs.

84. Compensation for delay:

If the Contractor fails to complete the works and clear the site on or before the Contract or extended date(s) / period(s) of completion, he shall, without prejudice to any other right or remedy of Municipal Corporation on account of such breach, pay as agreed compensation, amount calculated as stipulated below (or such smaller amount as may be fixed by the Engineer) on the contract value of the whole work or on the contract value of the time or group of items of work for which separate period of completion are given in the contract and of which completion is delayed for every week that the whole of the work of item or group of items of work concerned remains uncompleted, even though the contract as a whole be completed by the contract or the extended date of completion. For this purpose the term 'Contract Value' shall be the value of the work at Contract Rates as ordered including the value of all deviations ordered:

- Completion period for projects (originally stipulated or as extended) not exceeding 6 months : to the extent of maximum 1 percent per week.
- Completion period for projects (originally stipulated or as extended) exceeding 6 months and not exceeding 2 years: to the extent of maximum $\frac{1}{2}$ percent per week.
- Completion period for projects (originally stipulated or as extended) exceeding 2 years : to the extent of maximum $\frac{1}{4}$ percent per week.

When the delay is not a full week or in multiple of a week but involves a fraction of a week the compensation payable for that fraction shall be proportional to the number of days involved.

Provided always that the total amount of compensation for delay to be paid this condition shall not exceed the undernoted percentage of the Contract Value of the item or group of items of work for which a separate period of completion is given.

- i) Completion period (as originally stipulated or as extended) not exceeding 6 months: 10 percent.
- ii) Completion period (as originally stipulated or as extended) exceeding 6 months and not exceeding 2 years : $7\frac{1}{2}$ percent.
- iii) Completion period (as originally stipulated or as extended) exceeding 2 years : 5 percent.

The amount of compensation may be adjusted set off against any sum payable to the contractor under this or any other contract with the Municipal Corporation.

85. Action And Compensation Payable In Case Of Bad Work And Not Done As Per Specifications

All works under or in course of execution or executed in pursuance of the contract, shall at all times be open and accessible to the inspection and supervision of the Engineer-in-charge, his authorized subordinates in charge of the work and all the superior officers, officer of the Vigilance Department of the BMC or any organization engaged by the BMC for Quality Assurance and the contractor shall, at all times, during the usual working hours and at all other times at which reasonable notice of the visit of such officers has been given to the contractor, either himself be present to receive orders and instructions or have a responsible agent duly accredited in writing, present for that purpose. Orders given to the Contractor's agent shall be considered to have the same force as if they had been given to the contractor himself.

If it shall appear to the Engineer-in-charge or his authorized subordinates in-charge of the work or to the officer of Vigilance Department, that any work has been executed with unsound, imperfect or unskillful workmanship or with materials of any inferior description, or that any materials or articles provided by him for the execution of the work are unsound or of a quality inferior to that contracted for or otherwise not in accordance with the contract, the contractor shall, on demand in writing which shall be made within twelve months of the completion of the work from the Engineer-in-Charge specifying the work, materials or articles complained of notwithstanding that the same may have been passed, certified and paid for forthwith rectify, or remove and reconstruct the work so specified in whole or in part, as the case may require or as the case may be, remove the materials or articles so specified and provide other proper and suitable materials or articles at his own charge and cost. In the event of the failing to do so within a period specified by the Engineer-in-Charge in his demand aforesaid, then the contractor shall be liable to pay compensation at the same rate as under clause 8.e. of the general condition of contract in section 9 of tender document (for Compensation for delay) for this default. In such case the Engineer-in Charge may not accept the item of work at the rates applicable under the contract but may accept such items at reduced rates as the Engineer in charge may consider reasonable during the preparation of on account bills or final bill if the item is so acceptable without detriment to the safety and utility of the item and the structure or he may reject the work outright without any payment and/or get it and other connected and incidental items rectified, or removed and re-executed at the risk and cost of the contractor. Decision of the Engineer-in-Charge to be conveyed in writing in respect of the same will be final and binding on the contractor.

If the penalization amount exceeds maximum limit with respect to Clause 8.e of Standard General Conditions of Contract, then a show cause notice shall necessarily be issued to the contract as to why the contract should not be terminated.

86. Contractors remain liable to pay compensation:

In any case in which any of the powers conferred upon the Engineer In-charge by the relevant clauses in documents that form a part of contract as exercised or is exercisable in the event of any future case of default by the Contractor, he is declared liable to pay compensation amounting to the whole of his security deposit. The liability of the Contractor for past and future compensation shall remain unaffected.

In the event of the Executive Engineer taking action against these relevant clauses, he may, if he so desires, take possession of all or any tools and plant, materials and stores in or upon the work of site thereof or belonging to the Contractor or procured by him and intended to be used for the execution of the work or any part thereof paying or allowing for the same in account at the contract rates, or in the case of contract rates not being applicable at current market rates to be certified by the Executive Engineer, may after giving notice in writing to the Contractor or his staff of the work or other authorized agent require him to remove such tools and plants, materials or stores from the premises within a time to be specified in such notice and in the event of the Contractor failing to comply with any such requisition, the Executive Engineer may remove them at the contractors expense of sell them by auction or private sell on account of the Contractor at his risk in all respects and certificate of the Executive Engineer as to the expense of any such removal and the amount of the proceeds an expense of any such sell be final and conclusive against the Contractor.

87. No Claim to Any Payment Or Compensation Or Alteration In Or Restriction Of Work

(a) If at any time after the execution of contract documents, the Engineer shall for any reason whatsoever, desires that the whole or any part of the works specified in the Tender should be suspended for any period or that the whole or part of the work should not be carried out, at all, he shall give to the Contractor a Notice in writing of such desire and upon the receipt of such notice, the Contractor shall forthwith suspend or stop the work wholly or in part as required after having due regard to the appropriate stage at which the work should be stopped or suspended so as not to cause any damage or injury the work already done or endanger the safety thereof, provided that the decision of the Engineer as to the stage at which the work or any part of it could be or could have been safely stopped or suspended shall be final and conclusive against the contractor.

The Contractor shall have no claim to any payment or compensation whatsoever by reason of or in pursuance of any notice as aforesaid, on account of any suspension, stoppage or curtailment except to the extent specified hereinafter.

(b) Where the total suspension of Work Order as aforesaid continued for a continuous period exceeding 90 days the contractor shall be at liberty to withdraw from the contractual obligations under the contract so far as it pertains to the unexecuted part of the work by giving 10 days prior notice in writing to the Engineer within 30 days of the expiry of the said period of 90 days, of such intention and requiring the Engineering to record the final measurement of the work already done and to pay final bill. Upon giving such Notice, the Contractor shall be deemed to have been discharged from his obligations to complete the remaining unexecuted work under his contract. On receipt of such notice the Engineer shall proceed to complete the measurement and make such payment as may be finally due to the contractor within a period of 90 days from the receipt of such Notice in respect of the work already done by the contractor. Such payment shall not in any manner prejudice the right of the contractor to any further compensation under the remaining provisions of this clause.

(c) Where the Engineer required to Contractor to suspend the work for a period in excess of 30 days at any time or 60 days in the aggregate, the Contractor shall be entitled to apply to the Engineer within 30 days of the resumption of the work after such suspension for payment of compensation to the extent of pecuniary loss suffered by him in respect of working machinery remained ideal on the site of on the account of his having an to pay the salary of wages and labour engaged by him during the said period of suspension provided always that the contractor shall not be entitled to any claim in respect of any such working machinery, salary or wages for the first 30 days whether consecutive or in the aggregate or such suspension or in respect of any such suspension whatsoever occasion by unsatisfactory work or any other default on his part, the decision of the Engineer in this regard shall be final and conclusive against the contractor.

88. Contractor to supply plant, ladder, scaffolding, etc and is liable for damages arising from non-provision of lights, fencing, etc.

The Contractor shall supply at his own cost all material, plant, tools, appliances, implements, ladders, cordage, tackle scaffolding and temporary works requisite or proper for the proper execution of the work, whether, in the original altered or substituted form and whether included in the specification of other documents forming part of the contract or referred to in these conditions or not and which may be necessary for the purpose of satisfying or complying with the requirements of the Engineer-In-Charge as to any matter as to which under these conditions is entitled to be satisfied, or which is entitled to require together with the carriage therefore to and from the work.

The Contractor shall also supply without charge, the requisite number of person with the means and materials necessary for the purpose of setting out works and counting, weighing and assisting in the measurements of examination at any time and from time to time of the

work or materials, failing which the same may be provided by the Engineer In-charge at the expense of the contractor and the expenses may be deducted from any money due to the contractor under the contract or from his security deposit or the proceeds of sale thereof, or offers sufficient portion thereof.

The contractor shall provide all necessary fencing and lights required to protect the public from accident and shall also be bound to bear the expenses of defence of every suit, action or other legal proceedings, that may be brought by any person for injury sustained owing to neglect of the above precautions and to pay any damages and cost which may be awarded in any such suit action or proceedings to any such person or which may with the consent of the contractor be paid for compromising any claim by any such person.

89. Prevention of Fire: The contractor shall not set fire to any standing jungle, trees, brushwood or grass without a written permit from the Engineer In-charge. When such permit is given, and also in all cases when destroying cut or dug up trees brushwood, grass, etc., by fire, the contractor shall take necessary measure to prevent such fire spreading to or otherwise damaging surrounding property. The Contractor shall make his own arrangements for drinking water for the labour employed by him.

90. Compensation for all damages done intentionally or unintentionally by contractor's labour whether in or beyond the limits of BMC property including any damage caused by spreading the fire shall be estimated by the Engineer In-charge or such other officer as he may appoint and the estimate of the Engineer in-charge to the decision of the Dy. Chief Engineer on appeal shall be final and the contractor shall be bound to pay the amount of the assessed compensation on demand failing which the same will be recovered from the Contractor as damages or deducted by the Engineer In-charge from any sums that may be due or become due from BMC to contractor under this Contract or otherwise. Contractor shall bear the expenses of defending any action or other legal proceedings that may be brought to prevent the spread of fire and he shall pay any damages and costs that may be awarded by the Court in consequence.

91. In the case of Tender by partners, any change in the constitution of the firm shall be forthwith, notified by the contractor through the Engineer In-charge for his information.

92. Action where no specifications:

In the case of any class of work for which there is no such specifications, such works shall be carried out in accordance with the specifications and in the event of there being no such specifications, then in such case, the work shall be carried out in all respects in accordance with all instructions and requirements of the Engineer In-charge.

93. Safety and medical help:

(i) The Contractor shall be responsible for and shall pay the expenses of providing medical help to any workmen who may suffer a bodily injury as a result of an accident. If such

expenses are incurred by BMC, the same shall be recoverable from the contractor forthwith and be included without prejudice to any other remedy of BMC from any amount due or that may become due to the Contractor.

(ii) The contractor shall provide necessary personal safety equipment and first-aid box for the use of persons employed on the site and shall maintain the same in condition suitable for immediate use at any time.

(iii) The workers shall be required to use the safety equipments so provided by the contractor and the contractor shall take adequate steps to ensure the proper use of equipments by those concerned.

(iv) When the work is carried on in proximity to any place where there is risk or drawing all necessary equipments shall be provided and kept ready for use and all necessary steps shall be taken for the prompt rescue of any person in danger.

94. No compensation shall be allowed for any delay caused in the starting of the work on account of acquisition of land or in the case of clearance of works, on account of any delay in according to sanction of estimates.

95. Anti-malaria and other health measures: Anti-Malaria and other health measures shall be taken as directed by the Executive Health Officer of BMC. Contractor shall see that mosquitogenic conditions are created so as to keep vector population to minimum level. Contractor shall carry out anti-malaria measures in the area as per the guidelines issued by the Executive Health Officer of BMC from time to time.

In case of default, in carrying out prescribed anti-malaria measures resulting in increase in malaria incidence, contractor shall be liable to pay BMC on anti-malaria measures to control the situation in addition to fine.

SECTION 10
SPECIFICATIONS

Subject: Operation of Trash Rack cleaning machine installed near Pumping station Pise for the period of Six months.

SCOPE OF WORK AND TECHNICAL SPECIFICATIONS

A) DETAILS OF TRCM:

Main components of TRCM are as follows:

- 1) **Chassis:** is the main base of machine. It is assembled of 2 carriers and the flange steelwork. The carriers are divided into downstream side and upstream side. Equipped with 4 wheels and 2 hydraulic drives, the chassis enables the trash rack cleaning machine to move sideways along the rail system over the entire width of the trash rack. At the downstream of the chassis, cable trolley assembly is mounted for carrying the trailing cables.

For safe access to all component of base, the chassis is equipped with platforms and handrails for fall protection.

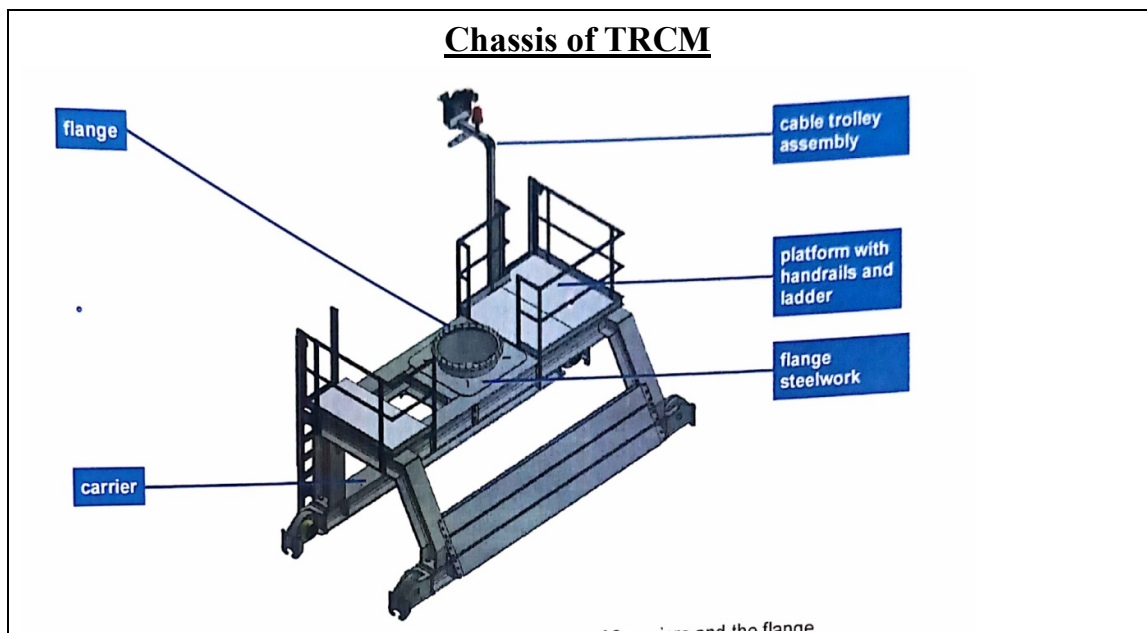

- 2) **Base:** The base is mounted on the flange of chassis. The boom is mounted on the base assembly, located at the Centre of the base. The base assembly forms the interface between base & bottom.

The counterweight on the backside of base ensures the balance centre of gravity and secure stability under all opening conditions.

The control cabinet & HPU housing are located to the left & right of the base assembly. The control cabinet contains the complete electrical control & has

both integrated ventilation & heating. The HPU housing contains the hydraulic power unit and has an integrated oil cooler.

- 3) **Boom:** The boom is made in 2 parts. It consist of articulated arm and the swivel arm. The articulated arm is mounted at the lower end to rotate on the base via. Bearing pins. At the upper end, the arcuated arm is connected to the upper end of the swivel arm by means of bearing pins. At the lower end of swivel arm is the rake console to mount the rake.

Trash Rack Cleaning Machine(TRCM)

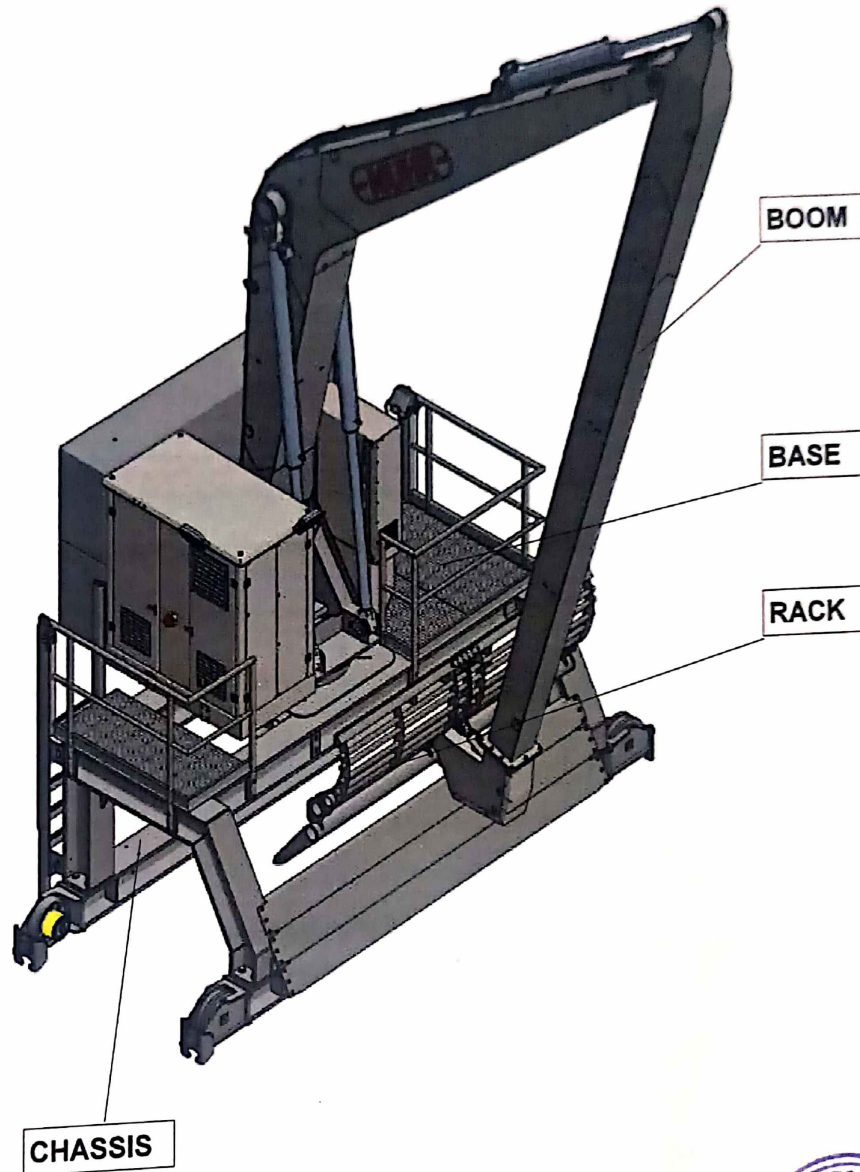
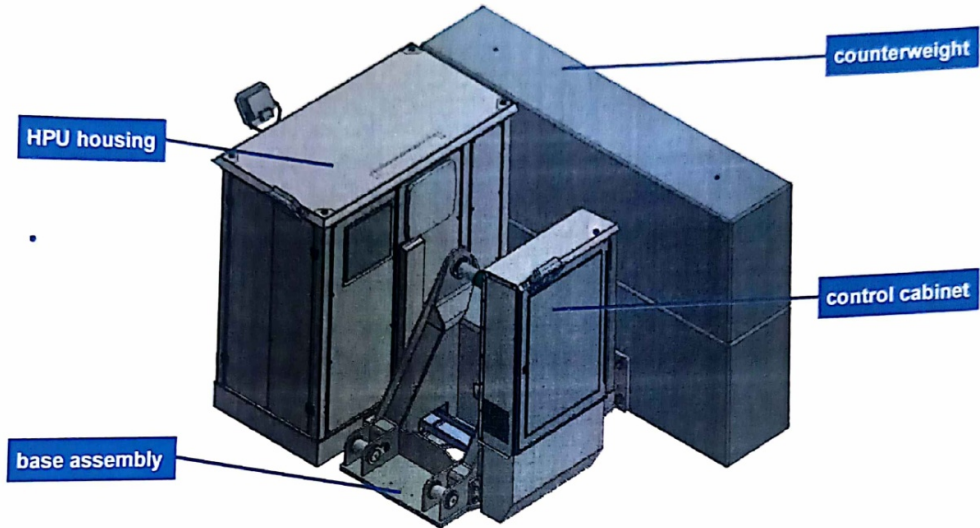



Figure 1.1. The articulated



- 4) **The entire boom is driven by 3 hydraulic cylinders:** 2 lifting cylinders lift and lower the upper part of the boom (articulated arm), the swiveling cylinder swivels the lower part of the boom (swivel arm) in & out.

The 2 part rake is open & closed using two further hydraulic cylinders (rake cylinders), one cylinder each for the bottom grap and the top grap

Functions: The cleaning process starts with opening the rake and swiveling out the swivel arm, power by swivel cylinder.

B) SCOPE OF THE WORK:

- i) The tenderer shall visit the site and shall get acquainted with the nature and scope of the work before submitting his offer. Claims arising out of ignorance of site condition will not be entertained.

ii) **Operation of TRCM:**

The Trash Rack cleaning machine shall be operated for the period of Six months for total 180 shifts throughout the year. All necessary skilled manpower shall be provided. During operation of one year, the installation shall be maintained in an approved manner and in accordance with BMC engineer's recommendation.

The contractor will have to operate the TRCM in good workmanship following best engineering practice so as to have smooth functioning of TRCM all the time.

Working Hours: The TRCM shall be operated in one shift per day i.e. (8.00 AM to 4.00 PM). It shall also be operated in second shift during rainy season as & when required. The duty hours for the contractual staff shall be of 8 hrs per shift.

The shift timings are:

1st shift - 8:00 AM to 4:00 PM

2nd shift -4:00 PM to 12:00 Midnight

- iii) **Contractor's staff for operation:** For the operation of TRCM, contractor shall engage adequate work force, skilled and experienced in their respective trades. For this purpose, contractor shall engage operators & labour staff as may be necessary for hassle free operation of TRCM.

Contractor shall deploy One operator, One assistant operator & 2 helpers in each shift. Contractor shall furnish list of staff engage for satisfactory operation of TRCM as per tender specifications. All the staff shall wear uniform with photo Identity card while on duty, the same shall be provided by the contractor. If any staff remains absent, contractor shall provide substitute staff.

The contractor shall arrange the transportation of removed floating material & submerged materials to the dumping spot/ground as by suitable means time to time as decided by BMC engineer.

The contractor shall clean & maintain entire screen and remove floating vegetation nearby screen from intake channel in every shift by operating TRCM . The contractor shall maintain TRCM machine , platform , track & complete sump gallery clean. The contractor shall also carry out cleaning of sump room –I,II & III.

After the expiry of Operation period, the TRCM shall be handed over to BMC in proper working condition within 10 days.

The tenderer shall fully co-operate & interact with BMC staff & other agencies / authorities at site, if involved.

- iv. The contractor shall carry out the works as mentioned in the schedule of quantities of this tender.
- v. The contractor shall arrange its own tools & tackles required for day to day operation & to attend emergency maintenance.
- vi. The contractor shall attend all minor breakdowns immediately to ensure smooth operation of TRCM.
- vii. Scope includes removal of silt deposited in sump room of all three Stages, underneath the girder of TRCM & walkway to sump room of Stage-I, II & III as per instructions of BMC engineer.
- viii. Contractor shall provide porta cabin for their operation staff.
- ix. The contractor shall ensure that all the safe working methods are adopted & shall provide safety gadgets such as helmet, gumboot, raincoat, fluorescent jacket, wherever necessary, while execution of work If any accident occurs, it will be on the account of the contractor & BMC shall not be responsible for any accidents / hazard.
- x. Any damage to Municipal property shall be recovered from the contractor. The contractor shall ensure that his staff works peacefully without causing any disturbance between themselves, Municipal Staff or with other agencies. The regular working of pumping system shall not be disturbed.
- xi. All the works of this contract will be supervised at site by BMC Engineers and the contractor shall follow instructions of site engineers as & when given for the work.
- xii. The contractor shall submit the list of authorized representatives & employees engaged for the work at the commencement of the contract. The contractor shall submit Name, Mobile Numbers and address of the authorized representative concerned, to whom the officers of BMC can contact for getting daily information or giving instructions during any contingencies or emergencies etc.
- xiii. Contractor shall follow minimum wage act strictly.
- xiv. Any other work not specified but necessary to carry out smooth operation of TRCM is in the scope of the contractor.

Penalty:

- (a) If the Operation of TRCM is not started within specified period i.e. within 10 days from issue of P.O., a penalty of Rs.5,000/- per day will be imposed.
- (b) If the TRCM is not operated for any other reasons like absenteeism of operator, staff etc. a penalty of Rs.2500/- per shift will be imposed.
- (c) If the staff remains absent penalty of Rs.1000.00 per day per person will deducted from monthly bill
- (d) During inspection rounds of BMC engineers, if the contractors' staff found without uniform or Identity card or required PPE's as specified, at any instant, in such cases a penalty of Rs. 500/- per incidence per staff member will be recovered from contractor's monthly bills.
- (e) If the daily log sheet book is not found/filled/properly maintained at site, a penalty of Rs. 500/- per day will be imposed from the contractor's bill.

Term of Payment :

The payment for the work will be made monthly on pro-rata basis as per the working shifts.

**SECTION 11
FRAUD
AND
CORRUPT
PRACTICES**

FRAUD AND CORRUPT PRACTICES

□ The Applicants and their respective officers, employees, agents and advisers shall observe the highest standard of ethics during the Bidding Process. Notwithstanding anything to the contrary contained herein, the Authority may reject an Application without being liable in any manner whatsoever to the Applicant if it determines that the Applicant has, directly or indirectly or through an agent, engaged in corrupt practice, fraudulent practice, coercive practice, undesirable practice or restrictive practice in the Bidding Process.

□ Without prejudice to the rights of the Authority under relevant Clause hereinabove, if an Applicant is found by the Authority to have directly or indirectly or through an agent, engaged or indulged in any corrupt practice, fraudulent practice, coercive practice, undesirable practice or restrictive practice during the Bidding Process, such Applicant shall not be eligible to participate in any tender or RFQ issued by the Authority during a period of 2 (two) years from the date such Applicant is found by the Authority to have directly or indirectly or through an agent, engaged or indulged in any corrupt practice, fraudulent practice, coercive practice, undesirable practice or restrictive practice, as the case may be.

□ For the purposes of this Clause , the following terms shall have the meaning hereinafter respectively assigned to them:

A. “corrupt practice” means the offering, giving, receiving, or soliciting, directly or indirectly, of anything of value to influence the actions of any person connected with the Bidding Process (for avoidance of doubt, offering of employment to, or employing, or engaging in any manner whatsoever, directly or indirectly, any official of the Authority who is or has been associated in any manner, directly or indirectly, with the Bidding Process or the LOA or has dealt with matters concerning the Concession Agreement or arising there from, before or after the execution thereof, at any time prior to the expiry of one year from the date such official resigns or retires from or otherwise ceases to be in the service of the Authority, shall be deemed to constitute influencing the actions of a person connected with the Bidding Process); or save and except as permitted under the relevant sub clause, engaging in any manner whatsoever, whether during the Bidding Process or after the issue of the LOA or after the execution of the Concession Agreement, as the case may be, any person in respect of any matter relating to the Project or the LOA or the Concession Agreement, who at any time has been or is a legal, financial or technical adviser of the Authority in relation to any matter concerning the Project;

B. “fraudulent practice” means a misrepresentation or omission of facts or suppression of facts or disclosure of incomplete facts, in order to influence the Bidding Process ;

C. “coercive practice” means impairing or harming or threatening to impair or harm, directly or indirectly, any person or property to influence any persons participation or action in the Bidding Process;

D. “undesirable practice” means (i) establishing contact with any person connected with or employed or engaged by the Authority with the objective of canvassing, lobbying or in any manner influencing or attempting to influence the Bidding Process; or (ii) having a Conflict of Interest; and

E. “Restrictive practice” means forming a cartel or arriving at any understanding or arrangement among Applicants with the objective of restricting or manipulating a full and fair competition in the Bidding Process.

F. If the Employer/Financier determines that the Contractor has engaged in corrupt, fraudulent, collusive, coercive or obstructive practices, in competing for or in executing the Contract, then the Employer may, after giving 14 days’ notice to the Contractor, terminate the Contractor's employment under the Contract and expel him from the Site, and the provisions of relevant Clause shall apply as if such expulsion had been made.

G. Should any employee of the Contractor be determined to have engaged in corrupt, fraudulent, collusive, coercive, or obstructive practice during the execution of the Works, then that employee shall be removed in accordance with relevant Clause.

For the purposes of this Sub-Clause:

i. “corrupt practice” is the offering, giving, receiving to soliciting, directly or indirectly, of anything of value to influence improperly the actions of another party;

ii. “another party” refers to a public official acting in relation to the procurement process or contract execution. In this context, “public official” includes Financier staff and employees of other organizations taking or reviewing procurement decisions.

iii. “fraudulent practice” is any act or omission, including a misrepresentation, that knowingly or recklessly misleads, or attempts to mislead, a party to obtain a financial or other benefit or to avoid an obligation;

iv. “collusive practice” is an arrangement between two or more parties designed to achieve an improper purpose, including to influence improperly the actions of another party;

v. “coercive practice” is impairing or harming, or threatening to impair or harm, directly or indirectly, any party or the property of the party to influence improperly the actions of a party;

vi. “obstructive practice” is deliberately destroying, falsifying, altering or concealing of evidence material to the investigation or making false statements to investigators in order to

materially impede the Financier investigation into allegations of a corrupt, fraudulent, coercive or collusive practice; and/or threatening, harassing or intimidating any party to prevent it from disclosing its knowledge of matters relevant to the investigation or from pursuing the investigation; or acts intended to materially impede the exercise of the Financier's inspection and audit rights provided

vii. "party" refers to a public official; the terms "benefit" and "obligation" relate to the procurement process or contract execution; and the "act or omission" is intended to influence the procurement process or contract execution.

viii. "parties" refers to participants in the procurement process (including public officials) attempting to establish bid prices at artificial, noncompetitive levels.

ix. a "party" refers to a participant in the procurement process or contract execution.

SECTION 12
PRE BID MEETING

PREBID MEETING (Not Applicable)

~~Pre bid meeting of the interested parties shall be convened at the designated date, time and at HE office, Worli Engineering Hub. A maximum of one representative of each Applicant shall be allowed to participate on production of authority letter from the Applicant.~~

~~During the course of Pre bid meeting, the Applicants will be free to seek clarifications and make suggestions for consideration of the Authority. The Authority shall endeavor to provide clarifications and such further information as it may, in its sole discretion, consider appropriate for facilitating a fair, transparent and competitive Bidding Process.~~

~~**The letters mentioning the queries shall be submitted** on email id aeppjppc.he@BMC.gov.in **one day before the date of pre bid meeting upto 4 pm.** Only official representative having authority letter from the tenderer as mentioned above will be allowed to attend the pre bid meeting.~~

SECTION 13
List of approved bank

List of approved bank for Acceptance of Bank Guarantee

1. ~~The following banks with their Branches in Greater Mumbai from Churchgate to Virar & from CST to Kalyan have been approved only for the purpose of accepting Banker's guarantee from 1994-95 onwards until further instructions.~~
2. ~~The Banker's guarantee issued by branches of approved Banks beyond Kalyan and Virar can be accepted only if the said Banker's Guarantee is countersigned by the Manager of a Branch of the same bank within the Mumbai city limits, categorically endorsing thereon that the said Banker's Guarantee is binding on the endorsing Branch of the Bank within Mumbai limits and is liable to be enforced against the said Branch of the Bank in case of default by the bidder / supplier furnishing the Banker's Guarantee.~~

3. List of approved bank

A S.B.I and its subsidiary Banks

- 1 ~~State Bank Of India.~~
- 2 ~~State Bank Of Bikaner & Jaipur.~~
- 3 ~~State Bank Of Hyderabad.~~
- 4 ~~State Bank Of Mysore.~~
- 5 ~~State Bank Of Patiyala.~~
- 6 ~~State Bank Of Saurashtra.~~
- 7 ~~State Bank Of Travankore.~~

B Nationalized Banks

- 8 ~~Allahabad Bank.~~
- 9 ~~Andhra Bank.~~
- 10 ~~Bank Of Baroda.~~
- 11 ~~Bank Of India.~~
- 12 ~~Bank Of Maharashtra.~~
- 13 ~~Central Bank Of India.~~
- 14 ~~Dena Bank.~~
- 15 ~~Indian Bank.~~
- 16 ~~Indian Overseas Bank.~~
- 17 ~~Oriental Bank Of Commerce.~~
- 18 ~~Punjab National Bank.~~
- 19 ~~Punjab & Sindh Bank.~~
- 20 ~~Syndicate Bank.~~
- 21 ~~Union Bank Of India.~~
- 22 ~~United Bank Of India.~~
- 23 ~~UCO Bank.~~
- 24 ~~Vijaya Bank.~~
- 24A ~~Corporation Bank.~~

C Scheduled Commercial Banks

- 25 ~~Bank Of Madura Ltd.~~
- 26 ~~Bank Of Rajasthan Ltd.~~
- 27 ~~Banaras State Bank Ltd.~~
- 28 ~~Bharat Overseas Bank Ltd.~~
- 29 ~~Catholic Syrian Bank Ltd.~~
- 30 ~~City Union Bank Ltd.~~
- 31 ~~Development Credit Bank.~~
- 32 ~~Dhanalakshmi Bank Ltd.~~
- 33 ~~Federal Bank Ltd.~~
- 34 ~~Indsind Bank Ltd.~~
- 35 ~~I.C.I.C.I Banking Corporation Ltd.~~

- 36 Global Trust Bank Ltd.
 37 Jammu & Kashmir Bank Ltd.
 38 Karnataka Bank Ltd.
 39 KarurVysya Bank Ltd.
 40 Laxmi Vilas Bank Ltd.
 41 Nedugundi Bank Ltd.
 42 Ratnakar Bank Ltd.
 43 Sangli Bank Ltd.
 44 South Indian Bank Ltd.
 45 S.B.I Corporation & Int Bank Ltd.
 46 Tamilnadu Mercantile Bank Ltd.
 47 United Western Bank Ltd.
 48 Vysya Bank Ltd.

D Schedule Urban Co-op Banks

- 49 Abhyudaya Co-op Bank Ltd.
 50 Bassein Catholic Co-op Bank Ltd.
 51 Bharat Co-op Bank Ltd.
 52 Bombay Mercantile Co-op Bank Ltd.
 53 Cosmos Co-op Bank Ltd.
 54 Greater Mumbai Co-op Bank Ltd.
 55 JanataSahakari Bank Ltd.
 56 Mumbai District Central Co-op Bank Ltd.
 57 Maharashtra State Co-op Bank Ltd.
 58 New India Co-op Bank Ltd.
 59 North Canara G.S.B. Co-op Bank Ltd.
 60 Rupee Co-op Bank Ltd.
 61 Sangli Urban Co-op Bank Ltd.
 62 Saraswat Co-op Bank Ltd.
 63 ShamraoVithal Co-op Bank Ltd.
 64 Mahanagar Co-op Bank Ltd.
 65 Citizen Bank Ltd.
 66 Yes Bank Ltd.

E Foreign Banks

- 67 ABM AMRO (N.Y.) Bank.
 68 American Express Bank Ltd.
 69 ANZ Grindlays Bank Ltd.
 70 Bank Of America N.T. & S.A.
 71 Bank Of Tokyo Ltd.
 72 Bankindosuez.
 73 BanqueNationale de Paris.
 74 Barclays bank.
 75 City Bank N.A.
 76 Hongkong & Shanghai banking Corporation.
 77 Mitsui Taiyokbe Bank Ltd.
 78 Standard Chartered Bank.
 79 Cho Hung Bank.

SECTION -14
APPENDIX

FORM OF TENDER

(To be submitted with Technical Packet-B)

To,
The Municipal Commissioner for Greater Mumbai
Sir,

consideration of yours agreeing to refrain from so doing I/we agree not to withdraw the offer constituted by this tender before the date of communication to me/us of such notice of non/acceptance, which date shall be not later than ten days from the date of the decision of the Standing Committee or Education Committee of the Corporation, as maybe required under the Mumbai Municipal Corporation Act, not to accept this tender.(Subject to condition 5 below).

5. I/We also agree to keep this tender open for acceptance for a period of 180 days from the date fixed for opening the same and not to make any modifications in its terms and conditions which are not acceptable to the Corporation.

6. I/We agree that the Corporation shall, without prejudice to any other right or remedy, be at liberty to forfeit the said earnest money absolutely, if.

a. I/We fail to keep the tender open as aforesaid.

b. I/We fail to execute the formal contract or make the contract deposit when called upon to do so.

c. I/we do not commence the work on or before the date specified by the Engineer in his work order.

7. I/We hereby further agree to pay all the charges of whatsoever nature in connection with the preparation, stamping and execution of the said contract.

8. "I/We..... have failed in the accompanying tender with full knowledge of liabilities and, therefore, we will not raise any objection or dispute in any manner relating to any action, including forfeiture of deposit and blacklisting, for giving any information, which is found to be incorrect and against the instructions and directions given in this tender.

9. "I/We further agree and undertake that in the event it is revealed subsequently after the allotment of work/contract to me/us, that any information given by me/us in this tender is false or incorrect, I/We shall compensate the BRIHANMUMBAI MUNICIPAL CORPORATION for any such losses or inconvenience caused to the Corporation in any manner and will not resist any claim for such compensation on any ground whatsoever. I/we agree and undertake that I/we shall not claim in such case any amount by way of damages or compensation for cancellation of the contract given to me/us or any work assigned to me/us or is withdrawn by the Corporation,"

Address Yours faithfully,

.....
.....

Digital Signature of the Tenderer or the Firm

- 1.....
- 2.....
- 3.....
- 4.....

Full Name and private residential A/c No.
address of all the partners
constituting the Firm

- 1. Name of Bank
.....

- 2.
- 3. Name of Branch
- 4.
- 5. Vender No.

AGREEMENT FORM

Tender / Quotation

dated 20...

Standing Committee/Education Committee Resolution No.....

CONTRACT FOR THE
WORKS.....

.....
This agreement made this day of

Two thousand

Between

.....
inhabitants of Mumbai, carrying on business at.....

.....
in Bombay under the style and name of Messrs

.....(Hereinafter
called "the contractor of the one part and Shri

.....
the D.M.C. (S.E.) (hereinafter called "the commissioner" in which expression are included unless the inclusion is inconsistent with the context, or meaning thereof, his successor or successors for the time being holding the office of D.M.C. (S.E.) of the second part and the BRIHANMUMBAI MUNICIPAL CORPORATION(hereinafter called "the Corporation") of the third part, WHEREAS the contractor has tendered for the construction, completion and maintenance of the works described above and his tender has been accepted by the Commissioner (with the approval of the Standing Committee/Education Committee of the Corporation NOW THIS

THIS AGREEMENT WITNESSETH as follows:-In this agreement words and expressions shall have the same meanings as are respectively assigned to them in the General Conditions of Contract for works hereinafter referred to:-The following documents shall be deemed to form and be read and constructed as a part of this agreement viz.

The letter of Acceptance

The Bid:

Addendum to Bid; if any

Tender Document

The Bill of Quantities:

The Specification:

Detailed Engineering Drawings

Standard General Conditions of Contracts (GCC)

All correspondence documents between bidder and BMC. In consideration of the payments to be made by the Commissioner to the contractor as hereinafter mentioned the contractor hereby covenants with the Commissioner to construct, complete and maintain the works in conformity in all respects with the provision of the contract. The Commissioner hereby covenants to pay to the Contractor in consideration of the construction, completion

and maintenance of the works the contract sum, at times and in the manner prescribed by the contract.

IN WITNESS WHERE OF the parties hereto have caused their respective common seals to be herein to affixed (or have hereunto set their respective hands and seals) the day and year above written.

Signed, Sealed and delivered by the contractors	
In the presence of	
Full Name	
Address	
Signed by the D.M.C. (S.E.) in the presence of	Ex. City/ WS/ ES
	D.M.C. (S.E.)
The Common seal of the BRIHANMUMBAI MUNICIPAL CORPORATION was hereunto affixed on the 20 in the presence of two members of the Standing Committee.	
1.	1.
2.	2.
And in the presence of the Municipal Secretary	Municipal Secretary

Annexure- B
(On Rs.500/- stamp paper)
PRE-CONTRACT INTEGRITY PAC
(To be submitted with Technical Packet-B)

The Bidder commits himself to take all measures necessary to prevent corrupt practices, unfair means and illegal activities during any stage of his bid or during any pre-contract or post-contract stage in order to secure the contract or in furtherance to secure it and in particular commits himself to the following:-

1. The Bidder will not offer, directly or through intermediaries, any bribe, gift, consideration, reward, favour, any material or immaterial benefit or other advantage, commission, fees, brokerage or inducement to any official of the BMC, connected directly or indirectly with the bidding process, or to any person, organization or third party related to the contract in exchange for any advantage in the bidding, evaluation, contracting and implementation of the Contract.
2. The Bidder further undertakes that he has not given, offered or promised to give, directly or indirectly any bribe, gift, consideration, reward, favour, any material or immaterial benefit or other advantage, commission, fees, brokerage or inducement to any official of the BMC or otherwise in procuring the Contract or forbearing to do or having done any act in relation to the obtaining or execution of the Contract or any other Contract with the Government for showing or forbearing to show favour or disfavour to any person in relation to the Contract or any other Contract with the Government.
3. The Bidder will not collude with other parties interested in the contract to impair the transparency, fairness and progress of the bidding process, bid evaluation, contracting and implementation of the contract.
4. The Bidder will not accept any advantage in exchange for any corrupt practice, unfair means and illegal activities.
5. The Bidder, either while presenting the bid or during pre-contract negotiations or before signing the contract, shall disclose any payments he has made, is committed to or intends to make to officials of the BMC or their family members, agents, brokers or any other intermediaries in connection with the contract and the details of services agreed upon for such payments.
6. The Bidder shall not use improperly, for purposes of competition or personal gain, or pass on to others, any information provided by the BMC as part of the business relationship, regarding plans, technical proposals and business details, including information contained in any electronic data carrier. The Bidder also undertakes to exercise due and adequate care lest any such information is divulged.
7. The Bidder commits to refrain from giving any complaint directly or through any other manner without supporting it with full and verifiable facts.

8. The Bidder shall not instigate or cause to instigate any third person to commit any of the actions mentioned above.

9. The Bidder and their respective officers, employees, agents and advisers shall observe the highest standard of ethics during the Bidding Process. Notwithstanding anything to the contrary contained herein, the Authority may reject an Application without being liable in any manner whatsoever to the Applicant if it determines that the Applicant has, directly or indirectly or through an agent, engaged in corrupt practice, fraudulent practice, coercive practice, undesirable practice or restrictive practice in the Bidding Process

For the purposes of this Clause 9, the following terms shall have the meaning herein after respectively assigned to them:

“fraudulent practice” means a misrepresentation or omission of facts or suppression of facts or disclosure of incomplete facts, in order to influence the Bidding Process ;

“coercive practice” means impairing or harming or threatening to impair or harm, directly or indirectly, any person or property to influence any persons participation or action in the Bidding Process;

“undesirable practice” means (i) establishing contact with any person connected with or employed or engaged by the Authority with the objective of canvassing, lobbying or in any manner influencing or attempting to influence the Bidding Process; or (ii) having a Conflict of Interest; and

“restrictive practice” means forming a cartel or arriving at any understanding or arrangement among Applicants with the objective of restricting or manipulating a full and fair competition in the Bidding Process.

Signature of Tenderer/Bidder

Annexure- C

(On Rs. 500/- Stamp Paper)

DECLARATION CUM INDEMNITY BOND

(To be submitted with Technical Packet-B)

I, _____ of _____, do hereby declared and undertake as under.

1. I declare that I have submitted certificates as required to Executive engineer (Monitoring) at the time of registration of my firm/company _____ and there is no change in the contents of the certificates that are submitted at the time of registration.
2. I declare that I _____ in capacity as Manager/Director/Partners/Proprietors of _____ has not been charged with any prohibitory and /or penal action such as banning(for specific time or permanent)/de-registration or any other action under the law by any Government and/or Semi Government and/or Government undertaking.
3. I declare that I have perused and examined the tender document including addendum, condition of contract, specifications, drawings, bill of quantity etc. forming part of tender and accordingly, I submit my offer to execute the work as per tender documents at the rates quoted by me in capacity as _____ of _____.
4. I further declare that if I am allotted the work and I failed to carry out the allotted work in accordance with the terms and conditions and within the time prescribed and specified, BMC is entitled to carry out the work allotted to me by any other means at my risk and cost, at any stage of the contract.
5. I also declare that I will not claim any charge/damages/compensation for non availability of site for the contract work at any time.
6. I declare that I will positively make the arrangements of the required equipment on the day of commencement or with respect to the progress of the work in phases, as per the instructions of site in charge

Signature of Tenderer/Bidder

PROFORMAS:

PROFORMA- I (To be submitted with Technical Packet-B)

The list of similar works as stated in eligibility criteria during last seven years-

PROFORMA- I					
Sr. No.	Name of the Project	Name of the employer	Stipulated date of completion	Actual date of completion	Actual Cost of work done
1	2	3	4	5	6

NOTE:

Scanned Attested copies of completion/performance certificates from the Engineer-in-Charge for each work should be annexed in the support of information furnished in the above proforma.

Works shall be grouped financial year-wise.

PROFORMA- II (To be submitted with Technical Packet-B)

Yearly turnover of Works during the last three years.

PROFORMA- II				
Sr.No.	Financial year	Annual Turnover of Works	Updated value to current year	Average of last 3 years

NOTE: The above figures shall tally with the audited balance sheets ed by the tenderers duly certified by Chartered Accountant.

PROFORMA- III (To be submitted with Technical Packet-B)

At least similar work, as stated in eligibility criteria.

PROFORMA- III

Name of the Project	Name of the Employer	Cost of the Project	Date of issue of work Order	Stipulated Date of Completion	Actual Date of Completion	Actual cost of work done	Remarks explaining reasons for delay, if any
1	2	3	4	5	6	7	8

Note: Scanned Attested copies of completion/performance certificates from the Engineer-in-charge for each work should be annexed in support of information furnished in the above proforma.

PERSONNEL:(To be submitted with Technical Packet-B)**PROFORMA- IV**

Sr. No.	Post	Name	Qualification	Work Experience
		(Prime Candidate/ Alternate)		No. of Years
1	Project Manager			
2	Quality Control Engineer			
3	Site Engineer			
4	Site Supervisor			

NOTE: Scanned Attested copies of qualification certificates and details of work experience shall be submitted /uploaded.

MACHINERY: (for special work only) Not applicable

PROFORMA- V/A		
Sr.No.	Equipment	Number

PROFORMA- V/B		
Sr.No.	Equipment	Number

Note: The tenderer(s) shall furnish/upload the requisite Scanned Attested documents of ownership/leased of machineries. The undertaking from the suppliers will not be accepted.

PROFORMA - VI / A (To be submitted with Technical Packet-B)

Details of Existing Commitments and ongoing works –

PROFORMA - VI / A							
Description of work	Place	Contract No. & Date	Name & Addresses of employer	Value of Contract in Rs.	Scheduled date of completion	Value of work remaining to be completed	Anticipated Date of completion

Note: Scanned Attested copies of work orders/completion/performance certificates from the Engineer-in-Charge for each work should be annexed in the support of information furnished in the above proforma.

PROFORMA - VI / B (To be submitted with Technical Packet-B)

Details of works for which bids are already uploaded –

PROFORMA - VI / B						
Description of work	Place	Name & Addresses of employee	Value of Contract in Rs.	Time Period	Date on which decision is expected	Remarks
1	2	3	4	5	6	7

PROFORMA- VII

Information on Litigation History in which the applicant is involved.

PROFORMA - VII				
Other Party (/Parties)	Employer	Cause of Dispute	Amount involved	Remarks showing Present Status.
1	2	3	4	5

AFFIDAVIT FOR BEST PRICE (on Rs. 500/- stamp paper)

(To be submitted with Technical Packet-B)

To

The Municipal Commissioner.

For the BRIHANMUMBAI MUNICIPAL CORPORATION

Sir,

Bid No. _____

"I/We _____ (full name in capital letters, starting with surname), the Proprietor/ Managing Partner/ Managing Director/ Holder of the Business/ Manufacturer/ Authorized Dealer, for the establishment/ firm / registered company, named herein below, do hereby, state and declare that I/We _____ whose names are given herein below in details with the addresses have not filled in this tender under any other name or under the name of any other establishment/ firm or otherwise, nor are we in any way related or concerned with any establishment/ firm or any other person, who have filled in the tender for the aforesaid work".

I/We do hereby further undertake that we have offered the best prices for the subject supply work as per the present market rates. **Further we do hereby undertake and commit that we have not offered/supplied the subject product/systems or sub systems in the past one year in Maharashtra State for quantity variation upto - 50% or + 10% at a price lower than that offered in the present bid to any other outside agencies including Govt./Semi Govt. agencies and within BMC also.** Further, we have filled in the accompanying tender with full knowledge of the above liabilities and therefore we will not raise any objection or dispute in any manner relating to any action including forfeiture of deposit and blacklisting, for giving any information which is found to be incorrect and against the instruction and direction given in this behalf in this tender.

"I/We further agree and undertake that in the event it is revealed subsequently after the allotment of work/ contract to me/ us that any information given by me/ us in this tender is false or incorrect, I/We shall compensate the BRIHANMUMBAI MUNICIPAL CORPORATION for any such losses or inconveniences caused to the Corporation in any manner and will not raise any claim for such compensation on any ground whatsoever. I/We agree and undertake that I/We shall not claim in such case any amount, by way of damages or compensation for cancellation of the contract given to me/ us or any work assigned to me/ us or is withdrawn by the Corporation".

However, in case of price difference, if it is a result of differential tax structures, different Dollar value of Rupee, differential logistic of transport etc. Considering this aspect, before invoking the penalty, blacklisting, I/We will be given a reasonable opportunity of being heard by representing our, case as to why such price variation/ differential has been arisen.

In case if the explanation submitted by me/ us is unsatisfactory then action including forfeiture of deposit & blacklisting may be taken against me/us.

TENDERER'S FULL SIGNATURE WITH FULL NAME AND RUBBER STAMP

(Note : This affidavit should be given on 500/-Rs. Stamp paper duly notarized by Notary with Red Seal and Registration number).

Annexure – A

Irrevocable Undertaking (Notarised)

(on Rs. 500/- Stamp paper)

(To be submitted with Technical Packet-B)

I Shri/Smt.....aged,.....years Indian Inhabitant. Proprietor/ Partner/ Director of M/s. resident at do hereby give Irrevocable undertaking as under;

1. I say & undertake that as specified in section 171 of CGST Act, 2017, any reduction in rate of tax on supply of goods or services or the benefit of input tax credit shall be mandotarily passed on to BMC by way of commensurate reduction in prices.

2. I further say and undertake that I understand tat in case the same is not passed on and is discovered at any later stage, BMC shall be at liberty to initiate legal action against me for its recovery including, but not limited to, an appeal to the Screening Committee of the GST Counsel.

3. I say that above said irrevocable undertaking is binding upon me/my partners/ company/ other Directors of the company and upon my/our legal heirs, assignee, Executor, administrator etc.

4. If I fail to compliance with the provisions of the GST Act, I shall be liable for penalty/ punishment or both as per the provisions of GST Act.

Whatever has been stated here in above is true & correct to my/ own knowledge & belief.

Solemnly affirmed at

DEPONANT

This day of

BEFORE ME

Interpreted Explained and Identified by me.

ANNEXURE
GRIEVANCE REDRESSAL MECHANISM
(To be submitted with Technical Packet-B)

BMC has formed a Grievance Redressal Mechanism for redressal of bidder's grievances. Any Bidder or prospective Bidder aggrieved by any decision, action or omission of the procuring entity being contrary to the provisions of the tender or any rules or guidelines issued therein. in Packet A. B&C can make an application for review of decision of responsiveness in Packet "A B & C within a period of 7 days or any such other period, as may be specified in the Bid document.

While making such an application to procuring entity for review, aggrieved bidders or prospective bidders shall clearly specify the ground or grounds in respect of which he feels aggrieved.

Provided that after declaration of a bidder as a successful in Packet A (General Requirements), an application for review may be filed only by a bidder who has participated in procurement proceedings and after declaration of successful bidder in Packet 'B' (Technical Bid). an application for review may be filed only by successful bidders of Packet A. Provided further that, an application for review of the financial bid can be submitted, by the bidder whose technical bid is found to be acceptable/responsive.

Upon receipt of such application for review, BMC may decide whether the bid process is required to be suspended pending disposal of such review. The BMC after examining the application and the documents available to him, give such reliefs, as may be considered appropriate and communicate its decision to the Applicant and if required to other bidders or prospective bidders, as the case may be.

BMC shall deal and dispose off such application as expeditiously as possible and in any case within 10 days from the date of receipt of such application or such other period as may be specified in pre-qualification document, bidder registration document or bid documents, as the case may be.

Where BMC fails to dispose off the application within the specified period or if the bidder or prospective bidder feels aggrieved by the decision of the procuring entity, such bidder or prospective bidder may file an application for redressal before the "Internal Procurement Redressal Committee" within 7 days of the expiry of the allowed time or of the date of receipt of the decision as the case may be. Every such application for internal redressal before Redressal Committee shall be accompanied by fee of Rs.25,000/- and fee shall be paid in the form of D.D. in favour of M.C.G.M.

1st Appeal by the bidder against the decision of C.E./ HOD/ Dean can be made concerned DMC/Director who should decide appeal in 7 days,If not satisfied, 2nd Appeal by the bidder can be made to concerned A.M.C.decision.

Grievance Redressal Committee (CRC) is headed by concerned D.M.CJ Director of particular department for the first appeal grievances by the bidder against the decision for responsiveness/non-responsiveness in Packet A Packet 11' or Packet C and if not satisfied, concerned A.M.C. will take decision as per second appeal made by the bidder.

This Grievance Redressal Committee (GRC) will be operated through DMC (CPD) office where appeals of aggrieved bidder will be received with fee of Rs. 25,000/- from aggrieved bidder. The necessary correspondence in respect of said applications to the aggrieved bidder & concerned department, issuing notices, arranging of Grievance Redressal Committee (GRC) with D.M.C. and further proceeding will be carried out through registrar appointed by MCGM.

No application shall be maintainable before the redressal Committee in regard of any decision of the BMC relating to following issues: Determination of need of procurement The decision of whether or not to enter into negotiations Cancellation of a procurement process for certain reasons.

On receipt of recommendation of the Committee, It will be communicate his decision thereon to the Applicant within 10 days or such further time not exceeding 20 days, as may be considered necessary from the date of receipt of the recommendation and in case of non-acceptance of any recommendation, the reason of such non-acceptance shall also be mentioned in such communication.

Additional Municipal Commissioner and/or Grievance Redressal Committee, if found, come to the conclusion that any such complaint or review is of vexatious, frivolous or malicious nature and submitted with the intention of delaying or defeating any procurement or causing loss to the procuring entity or any other bidder, then such complainant shall be punished with fine, which may extend to Five Lac rupees or two percent of the value of the procurement, whichever is higher.

Full Signature of the tenderer with Official Seal and Address