



E – Tender for the work of

“Manufacturing & Supply of refuse collection storage facility and enclosures at various locations in the wards of Mumbai.”

Website – portal.mcgm.gov.in/tenders

Tender ID No. 2024_MCGM_1061627_1

Due Date – 07/08/2024

Office of the

Deputy Chief Engineer (Solid Waste Management) Planning,

Fourth Floor, Municipal Khatav Market Building,

Opposite Avishkar Building, Khatavwadi, Sleater road,

Grant Road (W), Mumbai-400007

Phone:- 022-23877691/23844450

Email- (ee1swm.pl@mcgm.gov.in/

dycheswmpplanning.swm@mcgm.gov.in)

**Sd/-
S.E.(SWM)Pl.**

**Sd/-
A.E.(SWM)Pl.**

**Sd/-
E.E.(SWM)Pl.**

**Sd/-
Dy.Ch.E.(SWM)Pl.**

INDEX

SECTION	DESCRIPTION	PAGE NO.
1	E-TENDER NOTICE	4 to 7
2	ELIGIBILITYCRITERIA	8 to 11
3	DISCLAIMER	12 to 14
4	INTRODUCTION	15 to 16
5	E-TENDER ONLINESUBMISSION PROCESS	17 to 21
6	INSTRUCTIONS TO APPLICANTS	22 to 41
7	SCOPE OF WORK	42 to 43
8	BILL OF QUANTITIES	44 to 45
9	GENERAL CONDITIONS OF CONTRACT	46 to 105
10	SPECIFICATIONS	106 to 127
11	FRAUD AND CORRUPT PRACTICES	128 to 132
12	PRE-BID MEETING	133 to 134
13	LIST OF APPROVED BANKS	135 to 139
14	APPENDIX	140 to 145
15	ANNEXURE AND PROFORMAS	146 to 168

SECTION 1
E-TENDER
NOTICE

BRIHANMUMBAI MUNICIPAL CORPORATION

SOLID WASTE MANAGEMENT DEPARTMENT

E-TENDER NOTICE

Subject: Manufacturing & Supply of refuse collection storage facility and enclosures at various locations in the wards of Mumbai.

.....

Brihanmumbai Municipal Corporation (BMC) invites e-tender to appoint Contractor for the aforementioned work from contractors of repute, multidisciplinary engineering organizations i.e. Eminent firm, Proprietary/Partnership Firms/ Private Limited Companies/ Public Limited Companies/Companies registered under the Indian companies' act 2013.

The contractor who are not registered with BMC will have to apply for registering their firm within three month (03) months period from the award of contract, otherwise their Bid security i.e. E.M.D.(earnest money Deposit) will be forfeited/ recovered and an amount equal to Registration Fee of respective class will be recovered as penalty.

Bidding Process will comprise of THREE stages.

The application form can be downloaded from <https://mahatenders.gov.in> on payment of tender scrutiny fees of Rs. **15000+18%** GST. Tender Scrutiny Fees mentioned shall have to pay in the BMC's CFC after opening of Packet 'A' & Packet 'B' and before opening of packet C.

The applicants not registered with BMC are mandated to get registered (Vendor Registration) with BMC for e-tendering process & obtain login credentials to participate in the online bidding process.

i) To download the application form, for those applicants not having vendor registration, need to apply first for vendor registration at the office of Account Officer (FAR), 3rd floor, Municipal Headquarter.

ii) Followed by SRM login ID and password to be obtained from Central Purchase Department (CPD), Office at Byculla, Bakariadda, Mumbai

iii) For e-Tendering registration, enrolment for digital signature certificates and user manual, please refer to respective links provided in 'Tenders' tab.

Vendors can get digital signature from any one of the Certifying Authorities (CA's) licensed by controller of certifying authorities namely,

Safes crypt, IDRBT, National informatics centre, TCS, CUSTOMS, MTNL, GNFC and e- Mudhra CA.

Name of work	Contract Period
Manufacturing & Supply of refuse collection storage facility and enclosures at various locations in the wards of Mumbai	One Year (365 Days)

In terms of the 3 stage system of e-tendering, a Bidder will be required to deposit, along with its Bid, an Earnest Money of Rs. **23,76,400/-**

The E.M.D is refundable in accordance to the relevant clause of bid document, from the Bid Due Date, except in the case of the selected Bidder whose Bid Security/EMD shall be retained. The Bidders will have to provide Earnest Money Deposit through the payment gateways while submitting the bids. The Bid shall be summarily rejected if it is not accompanied by the Earnest Money Deposit. The e-tender is available on mahatenders portal (<https://mahatenders.gov.in>) as mentioned in the Header Data of the tender.

As per THREE Packet systems, the document for Packet A & B is to be uploaded by the bidder in vendors' document online in Packet A, B. Packet A,B & C shall be opened on dates as mentioned in header data. All the responsive and eligible bidders if they so wish can be present at the time of opening of bids, in the office of Dy. Ch. Eng.(SWM) Planning. The Packet C shall be opened if bids submission in Packet A & B satisfies/includes all the requirements and same are found acceptable to the Authority.

The Municipal Commissioner reserves the right to reject all or any of the e- tender(s) without assigning any reasons at any stage.

The dates and time for submission and opening the bids are as shown in the Header Data. If there are any changes in the dates the same will be displayed on 'Tenders Maharashtra' Portal. (<https://mahatenders.gov.in>) and also on BMC portal.

The Applicants interested for the above referred works may contact the Dy. Chief Eng. (SWM) Planning at the following address on any working day during office hours.

Office of the
Deputy Chief Engineer (Solid Waste Management) Planning,
Fourth Floor, Municipal Khatav Market Building,
Opposite Avishkar Building, Khatavwadi, Sleater road,
Grant Road (W), Mumbai-400007
Phone:- 022-23877691/23844450
Email- (ee1swm.pl@mcgm.gov.in/
dycheswmpplanning.swm@mcgm.gov.in)

The applicants may wish to visit the site under reference and can collect the information of the present status from the department who have invited the bids.

BMC reserves the rights to accept any of the application or reject any or all the application received for above works, without assigning any reasons thereof. The information regarding above subject matter is available on Website of 'Tenders Maharashtra' (<https://mahatenders.gov.in>).

Bidders are also advised to refer "Bidders Manual Kit" available at <https://mahatenders.gov.in/nicgep/app> page-> Bidders Manual Kit & service -> page for further details about the e-tendering process.

For any help, in the e-Tendering process, can be availed 24 x 7 by dialling help-desk number 012-4001 002/0120-4001 005 /120-6277 787 on all working days. Email sport Technical : support-eproc@nic.in.

SPECIAL NOTE :

TENDERERS ARE REQUESTED TO GO THROUGH THE e- TENDER GUIDELINES ON NIC PORTAL (<https://mahatenders.gov.in>).

Sd/-
Dy. Ch. Eng (SWM) Planning

HEADER DATA

Tender Document No.	2024_MCGM_1061627_1
Name of Organization	Brihanmumbai Municipal Corporation (BMC)
Subject	Manufacturing & Supply of refuse collection storage facility and enclosures at various locations in the wards of Mumbai.
Tender Scrutiny Fees	Rs. 15000+18% GST
EMD	Rs. 23,76,400.00
Bid Validity	180 days
Date of issue and sale of tender	01.08.2024 from 11:00Hrs
Last date & time for sale of tender & Receipt of Bid Security Deposit	07.08.2024 upto 16:00Hrs
Submission of Packet A, B & Packet C (Online)	07.08.2024 upto 16:01Hrs
Pre Bid Meeting	— .00.2024 at 15:00Hrs in the office of Ch. Eng. (SWM), Grant Road (W)
Opening of Packet A & B	08.08.2024 after 16:00Hrs
Opening of Packet C	12.08.2024 after 12.00hrs
Address for communication	Office of the Dy.Ch.Eng.(SWM) Planning Fourth Floor, Municipal Khatav Market Building, Opposite Avishkar Building, Khatavwadi, Sleater road, Grant Road (W), Mumbai-400007 Phone:- 022-23877691/23844450 Email- (ee1swm.pl@mcm.gov.in / dycheswmpplanning.swm@mcm.gov.in)
Venue for opening of bid	On line in Dy.Ch.Eng.(SWM) Pl.'s office

This tender document is not transferable.

BMC reserves the rights to reject any or all the application received for above subject without assigning any reason thereof.

**Sd/-
Dy. Ch. Eng. (S.W.M.) Planning**

SECTION 2

ELIGIBILITY CRITERIA

Eligibility Criteria

A 1.1 Technical Capacity

The tenderer(s) in their own name should have satisfactorily executed the work of similar nature or currently executing the work of similar nature as described in para 1.3 in BMC /Semi Govt. /Govt. & Public Sector Organizations during **last seven (7) years** ending last day of month previous to the one in which bids are invited as a prime Contractor

Three similar completed works each of value not less than amount as mentioned below (Rs.)	Two similar completed works each of value not less than amount as mentioned below (Rs.)	One similar completed works each of value not less than amount as mentioned below (Rs.)
Rs. 2,37,63,100.00	Rs. 2,97,03,900.00	Rs. 4,75,26,200.00

The value of executed works shall be brought to current costing level by enhancing the actual value of work at compound rate of 10 % per annum; calculated from the date of completion to last date of receipt of applications for tenders.

1.2 Financial Capacity

The Bidder shall have achieved an average annual financial turnover as certified by 'Chartered Accountant' not less than **Rs. 3,56,44,700.00** in financial year **2021-22, 2022-23, 2023-24**.

The value of each year's turnover shall be brought to current costing level by enhancing the actual value at compound rate of 10 % per annum; calculated from the date of completion to last date of receipt of applications for tenders.

1.3 Similar Experience:

"Similar work shall mean, the bidder shall have carried out the work of Supply of M.S. Refuse bins or container or vehicle for collection and storage waste in any Government / Semi-Government Organizations / Public Sector Undertakings in last seven years."

Note:- The bidder shall disclose the litigation history in packet ‘B’ under the head “Details of Litigation History”.

If there is no Litigation History, the bidder shall specifically mention that there is no Litigation History against him as per the clause of Litigation History. In case there is litigation History – Litigation History must cover – Any action of blacklisting, debarring, banning, suspension, deregistration and cheating with BMC, State Govt., Central Govt. or any authority under State or Central Govt./ Govt. Organization initiated against the company, firm, directors, partners or authorized signatory shall be disclosed for last 5 years from the date of submission of bid. Also, bidder must disclose the litigation history for last 5 years from the date of submission of bid about any action like show cause issued, blacklisting, debarring, banning, suspension, deregistration and cheating with BMC & BMC is party in the litigation against the company, firm, directors, partners or authorized signatory for carrying out any work for BMC by any authority of BMC and the orders passed by the competent authority or by any Court where BMC is a party. While taking decision on litigation history, the concerned Chief Engineer or D.M.C. or Director, as may be the case, should consider the details submitted by bidder and take decision based on the gravity of the litigation and the details submitted by the bidder and take decision based on the gravity of the litigation and the adverse effect of the act of company, firm, directors, partners or authorized signatory on the BMC works which can spoil the quantity, output, delivery of any goods or any work execution and within the timeframe.

1.4 Bid Capacity -Deleted

~~The Bidder shall have a **Bid Capacity** of an amount **not less than Rs.**~~

~~—The bid capacity of the prospective bidders will be calculated as under:~~

$$\del{\text{Assessed Available Bid Capacity} = (A * N * 2 - B)}$$

~~Where,~~

~~A = Maximum value of Engineering works executed in any one year (year means Financial year) during the last five years (updated to the price level of the Financial year in which bids are received at a rate of 10% per year, compounded annually) taking into account the completed as well as works in progress.~~

~~N = Number of years prescribed for completion of the Project/Works, excluding monsoon period, for which these bids are being invited. (E.g. 7 months = 7/12 year) For every intervening monsoon, 0.33 shall be added to N.~~

~~B = Value of existing commitments (only allotted works) on the last date of submission of bids as per bidding document and on-going works to be completed during the period of completion of the Project/Works for which these bids are being invited.~~

~~Note: The statement showing the value of existing commitments and on-going works as well as the stipulated period of completion remaining for each of the works listed should be attached along with certificates duly signed by the Engineer in Charge, not below the rank of an Executive Engineer or equivalent.~~

Even though the bidders meet the above qualifying criteria, they are subject to be disqualified if they:

- Have made misleading or false representation in the forms, statements and attachments submitted in proof of the qualification requirements; and/or
- Have record for poor performance such as abandoning the works, not properly completing the contract, inordinate delays in completion, or financial failures etc.

C) Joint Venture

Joint Venture is not allowed in this tender.

D) Infrastructural Set Up

The bidder shall have their well established office within the MMR Region. In case the bidder doesn't have an office he shall give an undertaking on Rs.500/- stamp paper that he shall set up an office within MMR within period of 90 days from the date of issue of LOA.

SECTION 3
DISCLAIMER

DISCLAIMER

The information contained in this e-tender document or provided to Applicant(s), whether verbally or in documentary or any other form, by or on behalf of the Brihanmumbai Municipal Corporation (BMC), hereafter also referred as "The Authority ", or any of its employees or advisors, is provided to Applicant(s) on the terms and conditions set out in this e-tender and such other terms and conditions subject to which such information is provided.

This e-tender includes statements, which reflect various assumptions and assessments arrived at by Brihanmumbai Municipal Corporation (BMC) in relation to the Project. Such assumptions, assessments and statements do not purport to contain all the information that each Applicant may require. This e-tender may not be appropriate for all persons, and it is not possible for the Brihanmumbai Municipal Corporation (BMC), its employees or advisors to consider the investment objectives, financial situation and particular needs of each party who reads or uses this e-tender. The assumptions, assessments, statements and information contained in this e-tender may not be complete, accurate, adequate or correct. Each Applicant should therefore, conduct its own investigations and analysis and should check the accuracy, adequacy, correctness, reliability and completeness of the assumptions, assessments, statements and information contained in this e-tender and obtain independent advice from appropriate sources.

Information provided in this e-tender to the Applicant(s) is on a wide range of matters, some of which may depend upon interpretation of law. The information given is not intended to be an exhaustive account of statutory requirements and should not be regarded as a complete or authoritative statement of law. Brihanmumbai Municipal Corporation (BMC) accepts no responsibility for the accuracy or otherwise for any interpretation or opinion on law expressed here.

Brihanmumbai Municipal Corporation (BMC), its employees and advisors make no representation or warranty and shall have no liability to any person, including any Applicant or Bidder, under any law, statute, rules or regulations or tort, principles of restitution or unjust

enrichment or otherwise for any loss, damages, cost or expense which may arise from or be incurred or suffered on account of anything contained in this e-tender or otherwise, including the accuracy, adequacy, correctness, completeness or reliability of the e-tender and any assessment, assumption, statement or information contained therein or deemed to form part of this e-tender or arising in any way with pre-qualification of Applicants for participation in the Bidding Process. Brihanmumbai Municipal Corporation (BMC) also accepts no liability of any nature whether resulting from negligence or otherwise howsoever caused arising from reliance of any applicant upon the statements contained in this e-tender.

Brihanmumbai Municipal Corporation (BMC) may, in its absolute discretion but without being under any obligation to do so, update, amend or supplement the information, assessment or assumptions contained in this e-tender.

The issue of this e-tender does not imply that Brihanmumbai Municipal Corporation (BMC) is bound to select and short-list pre-qualified Applications for Bid Stage or to appoint the selected Bidder or Concessionaire, as the case may be, for the Project and Brihanmumbai Municipal Corporation (BMC) reserves the right to reject all or any of the Applications or Bids without assigning any reasons whatsoever.

The Applicant shall bear all its costs associated with or relating to the preparation and submission of its Application including but not limited to preparation, copying, postage, delivery fees, expenses associated with any demonstrations or presentations which may be required by Brihanmumbai Municipal Corporation (BMC) or any other costs incurred in connection with or relating to its Application. All such costs and expenses will remain with the Applicant and Brihanmumbai Municipal Corporation (BMC) shall not be liable in any manner whatsoever for the same or for any other costs or other expenses incurred by an Applicant in preparation or submission of the Application, regardless of the conduct or outcome of the Bidding Process.

SECTION 4

INTRODUCTION

INTRODUCTION

1. Background:

Brihanmumbai Municipal Corporation (BMC) covers an area of 437.71sq.kms.with a population of **1.24 Crores as per census of 2011**. The metropolis accounts major portion of India's international trade and government's revenue, from being one of the foremost centres of education, science and technological research and advancement.

The Mumbai Metropolis has historic tradition of strong civic activism dedicated to the cause of a better life for all its citizens. And it's the Brihanmumbai Municipal Corporation (BMC), hereafter called the "corporation", the primary agency responsible for urban governance in Brihanmumbai.

BMC (The Authority) is one of the largest local self-governments in the Asian Continent. In observance of historic traditions of strong civic activism, with the change in time and living conditions to match with the urbanization, BMC has mainly focused in providing almost all kinds of engineering services viz, Hydraulics, storm water drain, sewerage, water supply projects, roads, bridges, solid waste management, and environmental services. Beside this, BMC is also providing dedicated services in various segments such as Health, Primary Education as well as the construction and maintenance of Public Markets and Slaughter Houses.

BMC is an organization having different departments, right from engineering depts. to health depts. Moreover we have other dept. like education, market, fire brigade dept. and other such departments where quite a good number of staff members are working.

**SECTION 5
E-TENDERING ONLINE
SUBMISSION PROCESS**

E-TENDERING ONLINE SUBMISSION PROCESS

TENDERERS ARE REQUESTED TO GO THROUGH THE e- TENDER GUIDELINES ON NIC PORTAL (<https://mahatenders.gov.in>). For registration, enrolment for digital signature certificate & user manual, please refer to respective links provided in e-tendering tab. The vendors can get digital signature from any one of the Certifying Authorities (CA's) licensed by the Controller of Certifying Authorities namely Safes crypt, IDRBT, National Informatics Centre, TCS, Customs, MTNL, GNFC and e- Mudhra.

~~The terminology of e-Tendering is solely depending upon policies in existence, guidelines and methodology adopted since decades. The SRM is only change in process of accepting and evaluation of tenders in addition to manual. The SAP module to be used in this E-tendering is known as Supplier Relationship Module (SRM).SRM is designed and introduced by ABM Knowledge ware Ltd. who will assist BMC in throughout the tendering process for successful implementation.~~

~~**NOTE:** This tendering process is covered under Information Technology ACT & Cyber Laws as applicable~~

~~(1) In e tendering process some of the terms and its definitions are to be read as under wherever it reflects in online tendering process.~~

~~Start Date read as "Sale Date"~~

~~End Date read as "Submission Date"~~

~~Supplier read as "Contractor/bidder"~~

~~Vendor read as "Contractor/bidder"~~

~~Vendor Quotation read as "Contractors Bid/Offer"~~

~~Purchaser read as "Department/BMC"~~

~~I. Before entering in to online tendering process, the contractors should complete the registration process so as to get User ID for E-tendering links. For this, the contractors can access through Supplier registration via BMC Portal.~~

~~There are two methods for this registration :(II and III)~~

~~II. Transfer from R3 (registered contractors with BMC) to SRM~~

- a. ~~Contractors already registered with BMC will approach to Vendor Transfer cell.~~
- b. ~~Submit his details such as (name, vendor code, address, registered Email ID, pan card etc.) to Vendor transfer cell.~~
- c. ~~BMC authority for Vendor Transfer, transfers the Vendor to SRM application from R3 system to SRM system.~~
- d. ~~Transferred Vendor receives User ID creation link on his supplied mail Id.~~
- e. ~~Vendor creates his User ID and Password for e-tendering applications by accessing link sent to his mail ID.~~

III. ~~Online Self Registration (Temporary registration for applicant not registered with BMC)~~

- a. ~~Vendor fills up Self Registration form via accessing BMC portal.~~
- b. ~~Vendor Transfer cell (same as mentioned above) accesses Supplier Registration system and accepts the Vendor request.~~
- c. ~~Accepted Vendor receives User ID creation email with Link on his supplied mail Id.~~
- d. ~~Vendor creates his User ID and Password for e-tendering application.~~

IV. **CONTRACTORS BIDDING:** ~~Applicant will Quote and Upload Tender Documents~~

1. ~~Access e-tender link of SRM Portal~~
2. ~~Log in with User ID and Password~~
3. ~~Selects desired Bid Invitation (he wants to bid)~~
4. ~~To download tender documents contractors will have to pay online Tender fee. The same can be done by accessing Pay Tender Fees option. By this one will be able to pay Tender fee through Payment Gateway. If transaction successful, Contractors can register his interest to participate. Without Registration one cannot quote for the Bid/Tender.~~
5. ~~Applicant will download Tender Documents from Information from purchaser tab by accessing Purchaser document folder through collaboration 'C' folder link.~~
6. ~~Applicant will upload Packet **A** related and Packet **B** related Documents in Packet **A** and Packet **B** folder respectively by accessing these~~

folders through “My Notes” Tab and collaboration folder link.

7. ~~All the documents uploaded have to be digitally signed and saved. Contractors can procure there digital signature from any certified CA's in India.~~

8. ~~Bid security deposit/EMD and ASD, if applicable, should be paid online as mentioned in tender.~~

9. ~~For commercial details (in Packet **C**) contractors will fill data in Item Data tab in Service Line Item figure.(If entered '0' it will be treated as at par. By default the value is zero only.~~

10. ~~Applicants to check the bid, digitally signs & save and submit his Bid Invitation.~~

11. ~~Applicants can also save his uploaded documents/commercial information without submitting the BID for future editing through 'HOLD' option.~~

12. ~~Please note that “Hold” action do not submit the Bid.~~

13. ~~Applicants will receive confirmation once the Bid is submitted.~~

14. ~~Bid creator (BMC) starts Bid Opening for Packet **A** after reaching End Date and Time and Bid Evaluation process starts.~~

~~As per Three Packet system, the document for Packet **A & B** is to be uploaded by the tenderer in 'Vendor's document' online in Packet A & B. Before purchasing/ downloading the tender copy, tenderer may refer to post-Qualification criteria mentioned in e-Tender Notice.~~

~~The tenderer shall pay the EMD/Bid Security through payment gateways before submission of Bid and shall upload the screenshot of receipt of payment in Packet '**A**' instead of paying the EMD at any of the CFC centres in BMC Ward Offices.~~

~~—The e-tender is available on BMC portal, <http://portal.mcgm.gov.in>, as mentioned in the Header Data of the tender. The tenders duly filled in should be uploaded and submitted online on or before the end date of submission. The Packet '**A**', Packet '**B**' & Packet '**C**' of the tenderer will be opened as per the time table shown in the Header Data in the office of Dy.Ch Eng.(SWM) Planning~~

~~The Municipal Commissioner reserves the right to reject all or any of the e Tender(s) without assigning any reason at any stage. The dates and~~

~~time for submission and opening the tenders are as shown in the Header Data. If there are any changes in the dates the same will be displayed on the BMC Portal (<http://portal.mcgm.gov.in>).~~

**SECTION 6
INSTRUCTIONS TO
APPLICANTS**

INSTRUCTIONS TO APPLICANTS

TENDERERS ARE REQUESTED TO GO THROUGH THE e- TENDER GUIDELINES ON NIC PORTAL (<https://mahatenders.gov.in>). For registration, enrolment for digital signature certificate & user manual, please refer to respective links provided in e-tendering tab. The vendors can get digital signature from any one of the Certifying Authorities (CA's) licensed by the Controller of Certifying Authorities namely Safes crypt, IDRBT, National Informatics Centre, TCS, Customs, MTNL, GNFC and e- Mudhra.

A. Scope of Application

The Authority wishes to receive Applications for Qualification in order to SELECT experienced and capable Applicants for the Bid Stage.

B. Eligibility of Applicants

Brihanmumbai Municipal Corporation (BMC) invites e-tender to appoint Contractor for the aforementioned work from contractors of repute, multidisciplinary engineering organizations i.e. eminent firm, Proprietary/Partnership Firms/ Private Limited Companies/ Public Limited Companies/ Companies registered under the Indian companies' act 2013

The contractors registered with the Brihanmumbai Municipal Corporation, (BMC) in **Class 'A'** as per new registration and from the contractors/firms equivalent and superior classes registered in Central or State Government/Semi Govt. Organization/Central or State Public Sector Undertakings, will be allowed subject to condition that, The contractor who are not registered with BMC will have to apply for registering their firm within three month (03) months period from the award of contract, otherwise their Bid security i.e. E.M.D.(earnest money Deposit) will be forfeited/ recovered and an

To be eligible for pre-qualification and short-listing, an Applicant shall fulfill the following conditions of eligibility:

A) 1.1 Technical Capacity

The tenderer(s) in their own name should have satisfactorily executed the work of similar nature or currently executing the work of similar nature as described in para 1.3 in MCGM /Semi Govt. /Govt. & Public Sector Organizations during **last seven (7) years** ending last day of month previous to the one in which bids are invited as a prime Contractor

Three similar completed works each of value not less than amount as mentioned below (Rs.)	Two similar completed works each of value not less than amount as mentioned below (Rs.)	One similar completed works each of value not less than amount as mentioned below (Rs.)
Rs. 2,37,63,100.00	Rs. 2,97,03,900.00	Rs. 4,75,26,200.00

The value of executed works shall be brought to current costing level by enhancing the actual value of work at compound rate of 10 % per annum; calculated from the date of completion to last date of receipt of applications for tenders.

1.2 Financial Capacity

The Bidder shall have achieved an average annual financial turnover as certified by 'Chartered Accountant' not less than **Rs. 3,56,44,700.00** in financial year **2021-22, 2022-23, 2023-24.**

The value of each year's turnover shall be brought to current costing level by enhancing the actual value at compound rate of 10 % per annum; calculated from the date of completion to last date of receipt of applications

1.3 Similar Experience:

"Similar work shall mean, the bidder shall have carried out the work of **Supply of M.S. Refuse bins or container or vehicle for collection and storage of waste** for any Government / Semi-Government Organizations / Public Sector Undertakings."

If there is no Litigation History, the bidder shall specifically mention that there is no Litigation History against him as per the clause of Litigation History. In case there is litigation History –

Litigation History must cover – Any action of blacklisting, debarring, banning, suspension, deregistration and cheating with BMC, State Govt., Central Govt. or any authority under State or Central Govt./ Govt. Organization initiated against the company, firm, directors, partners or authorized signatory shall be disclosed for last 5 years from the date of submission of bid. Also, bidder must disclose the litigation history for last 5 years from the date of submission of bid about any action like show cause issued, blacklisting, debarring, banning, suspension, deregistration and cheating with BMC & BMC is party in the litigation against the company, firm, directors, partners or authorized signatory for carrying out any work for BMC by any authority of BMC and the orders passed by the competent authority or by any Court where BMC is a party. While taking decision on litigation history, the concerned Chief Engineer or D.M.C. or Director, as may be the case, should consider the details submitted by bidder and take decision based on the gravity of the litigation and the details submitted by the bidder and take decision based on the gravity of the litigation and the adverse effect of the act of company, firm, directors, partners or authorized signatory on the BMC works which can spoil the quantity, output, delivery of any goods or any work execution and within the timeframe.

B. Bid Capacity- Deleted

~~The Bidder shall have a **Bid Capacity** of an amount **not less than Rs.**
The bid capacity of the prospective bidders will be calculated as under:~~

~~**Assessed Available Bid Capacity = (A* N* 2 – B)**~~

~~Where,~~

~~A = Maximum value of Engineering works executed in any one year (year means Financial year) during the last five years (updated to the price level of the Financial year in which bids are received at a rate of 10% per year, compounded annually) taking into account the completed as well as works in progress.~~

~~N = Number of years prescribed for completion of the Project/Works, excluding monsoon period, for which these bids are~~

~~being invited. (E.g. 7 months = 7/12 year) For every intervening monsoon, 0.33 shall be added to N.~~

~~B = Value of existing commitments (only allotted works) on the last date of submission of bids as per bidding document and on going works to be completed during the period of completion of the Project/Works for which these bids are being invited.~~

~~Note: The statement showing the value of existing commitments and on-going works as well as the stipulated period of completion remaining for each of the works listed should be attached along with certificates duly signed by the Engineer in Charge, not below the rank of an Executive Engineer or equivalent.~~

Even though the bidders meet the above qualifying criteria, they are subject to be disqualified if they:

- Have made misleading or false representation in the forms, statements and attachments submitted in proof of the qualification requirements; and/or
- Have record for poor performance such as abandoning the works, not properly completing the contract, inordinate delays in completion, or financial failures etc.

C) Joint Venture

Joint Venture is not allowed in this tender.

D) Infrastructural Set Up

The bidder shall have their well established office within the MMR Region. In case the bidder doesn't have an office he shall give an undertaking on Rs.500/- stamp paper that he shall set up an office within MMR within period of 90 days from the date of issue of LOA.

E) Equipment Capabilities as required for this work

The bidder should, undertake their own studies and **furnish with their bid**, a detailed planning and methodology supported with assessment study of requirements of equipment/vehicles & machineries to allow the employer to review their proposal. The successful bidder will make the arrangements of the required equipment/vehicles on the day of commencement or with respect to the progress of the work in phases, as per the instructions of site in charge and as per specifications. The successful

bidder and, to that effect he will ensure commitment on an undertaking on Rs.500/- stamp paper to be submitted along with the Bid in Packet B.

Bidders shall submit the undertaking for equipment/vehicle capability/machineries and other undertakings as such on a single Rs.500/- stamp paper.

F) Time Period of the Project

The **contract period is for 1 years (365 days)**, as mentioned in the specifications.

The time allowed for carrying out the work as entered in the Tender shall be strictly observed by the Contractor and shall be reckoned from the date on which the Letter of Acceptance is given to the Contractor. The work shall throughout the stipulated period of the Contract be proceeded with all due diligence as time being deemed to be the essence of the contract on the part of the Contractor.

The programme for completion of work for the period from the date of issue of letter of acceptance to the start date of the contract period shall be a part of the Contract Document in the form of Bar Chart / GANTT Chart. The Contractor is supposed to carry out the work and keep the progress as per Bar Chart/GANTT Chart. The Contractor shall complete the supply as per the Schedule

G) Contract Execution

All required documents for execution of the contract shall be submitted within 30 days from the date of issue of letter of acceptance. If the documents are not submitted within the stipulated time a penalty of Rs. 5000/- per day will be applicable to the contractor. All contract documents need to be duly affixed with stamp duty properly signed along with evidence/proof of payment of security/contract deposit/ within 30 days from the date of letter of acceptance received by him.

H) If the amount of the Contract Deposit to be paid above is not paid within 30 days from the date of issue of Letter of Acceptance, the Tender /

Contractor already accepted shall be considered as cancelled and legal steps will be taken against the contractor for recovery of the amounts.

- I) The amount of Security Deposit retained by the BMC shall be released after expiry of period up to which the contractor has agreed to maintain the work in good order is over. In the event of the contractor failing or neglecting to complete the rectification work within the period up to which the contractor has agreed to maintain the work in good order, the amount of security deposit retained by BMC shall be adjusted towards the excess cost incurred by the Department on rectification work.

J) Action when whole of security deposit is forfeited:

In any case in which under any Clause of this contract, the contractor shall have rendered himself liable to pay compensation amounting to the whole of this security deposit whether paid in one sum or deducted by instalments or in the case of abandonment of the work owing to serious illness or death of the contractor or any other cause, the Engineer on behalf of the Municipal Commissioner shall have power to adopt any of the following process, as he may deem best suited to the interest of BMC-

- a) To rescind the contract (for which recession notice in writing to the contractor under the head of Executive Engineer shall be conclusive evidence) and in that case, the security deposit of the contract shall stand forfeited and be absolutely at the disposal of BMC.
- b) To carry out the work or any part of the work departmentally debiting the contractor with the cost of the work, expenditure incurred on tools and plant, and charges on additional supervisory staff including the cost of work- charged establishment employed for getting the un-executed part of the work completed and crediting him with the value of the work done departmentally in all respects in the same manner and at the same rates as if it had been carried out by the contractor under the terms of his contract. The certificate of the Executive Engineer as to the costs and other allied expenses so incurred and as to the value of the work so done departmentally shall be final and conclusive against the contractor.

c) To order that the work of the contractor be measured up and to take such part thereof as shall be un-executed out of his hands, and to give it to another contractor to complete, in which case all expenses incurred on advertisement for fixing a new contracting agency, additional supervisory staff including the cost of work charged establishment and the cost of the work executed by the new contract agency will be debited to the contractor and the value of the work done or executed through the contractor shall be credited to the contractor in all respects and in the same manner and at the same rates as if it had been carried out by the new contractor under the terms of his contract. The certificate of the Executive Engineer as to all the cost of the work and other expenses incurred as aforesaid for or in getting the un-executed work done by the new contractor and as to the value of the work so done shall be final and conclusive against the contractor.

In case the contract shall be rescinded under Clause (a) above, the contractor shall not be entitled to recover or be paid any sum for any work therefore actually performed by him under this contract unless and until the Executive Engineer shall have certified in writing the performance of such work and the amount payable to him in respect thereof and he shall only be entitled to be paid the amount so certified. In the event of either of the courses referred to in Clause (b) or (c) being adopted and the cost of the work executed departmentally or through a new contractor and other allied expenses exceeding the value of such work credited to the contractors amount of excess shall be deducted from any money due to the contractor, by BMC under the contract or otherwise, howsoever, or from his security deposit or the sale proceeds thereof provided, however, the contractor shall have no claim against BMC even if the certified value of the work done departmentally or through a new contractor exceeds the certified cost of such work and allied expenses, provided always that whichever of the three courses mentioned in clauses (a), (b) or (c) is adopted by the Executive Engineer, the contractor shall have no claim to compensation for any loss sustained by him by reason of his having

purchase or procured any materials or entered in to any engagements or made any advance on account of or with a view to the execution of the work or the performance of the contract.

K) Contract may be rescinded and security deposit forfeited for bribing a public officer or if contractor becomes insolvent

If the contractor assigns or sublets his contracts or attempt so to do, or become insolvent or commence any proceeding to get himself adjudicated and insolvent or make any composition with his creditors, or attempt so to do or if bribe, gratuity, gift, loan, perquisite, reward or advantage, pecuniary or otherwise, shall either directly or indirectly be given promised or offered by the contractor or any of his servants or agents through any public officer, or person in the employ of BMC/Govt. in any way relating to his office or employment, or if any such officer or person shall become in any way directly or indirectly interested in the contract the Engineer In-charge may thereupon, by notice in writing rescind the contract and the Security Deposit of the Contractor shall thereupon stand forfeited and be absolutely at the disposal of BMC and the same consequences shall ensure as if the contract had been rescinded under above clause J hereof; and in addition the contractor shall not be entitled to recover or be paid for any work therefore actually performed under the contract.

➤ **Submission of Tenders**

PACKET – A

The Packet ‘A’ shall contain scanned copies of the following original documents-

Scrutiny of this packet will be done strictly with reference to only the scanned copies of Documents uploaded online in packet ‘A’

- a) Valid Registration Certificate.
- b) Valid Bank Solvency Certificate of **Rs. 1.5 Cr** not more than one year old from due date of the tender.
- c) A document in support of Registration under Maharashtra ‘Goods & Service Act 2017. GST Registration Certificate in Maharashtra (or equivalent requirement under GST). Those not registered in Maharashtra shall submit an undertaking to the effect that if they are successful tenderer, they shall submit GST Registration Certificate in Maharashtra within 15 days of issue of work order, failing which payment for the work executed will not be released.
- d) Certified copies of valid 'PAN' documents and photographs of the individuals, owners, Karta of Hindu Undivided Family, firms, private limited companies, registered co-operative societies, partners of partnership firms and at least two Directors, if number of Directors are more than two in case of Private Limited Companies, as the case may be. However, in case of Public Limited companies, Semi Government Undertakings, Government Undertakings, no 'PAN' documents will be insisted.
- e) Latest Partnership Deed in case of Partnership firm duly registered with Chief Accountant (Treasury) of BMC.

The bidders shall categorically provide their Email-ID in packet ‘A’.

NOTE:

- If the tenderer(s) withdraw tender offer during the tender validity period, his entire E.M.D shall be forfeited.
- If it is found that the tenderer has not submitted required documents in Packet “A” then, the shortfalls will be communicated to the tenderer through e-mail only and compliance required to be made within a time

period of **three working days** otherwise they will be treated as non-responsive.

PACKET – B

The Packet ‘B’ shall contain scanned copies of the following original documents-

- a) The list of similar type of works as stated in para ‘A’ section 1.3 on pg.-9 of Post qualification successfully completed during the last Seven years in prescribed proforma, in the role of prime contractor. Information furnished in the prescribed proforma (Proforma – I) shall be supported by the certificate duly self-attested. Documents stating that it has successfully completed during the last Seven years at least one contract of similar works as stated in para ‘A’ section 1.3 on pg.-9 of Post qualification.
- b) Annual financial turnover for **preceding three financial years as certified by Chartered Accountant** preceding the Financial Year in which bids are invited. **Copies of Applicants duly audited balance sheet and profit and loss account for the preceding three financial years preceding the Financial Year in which bids are invited.** (Proforma – II)
- c) Documents stating that, it has access to or has available liquid assets, unencumbered assets, lines of credit and other financial means (independent of any contractual advance payment) sufficient to meet the cash flow requirements for the subject contract in the event of stoppage, start-up, or other delay in payment, of the minimum 15% of the yearly cost of the work tendered for, net of the tenderer's commitment of other contracts (Certificate from Bankers / C.A./Financial Institution shall be accepted as a evidence).
- d) The bidder shall give undertaking on Rs. 500/-stamp paper that it is his/their sole responsibility to arrange the required machineries/ resources before start of the work.
 - i. Details of works in hand (Proforma VI-A & VI-B) (original), along with copies of work orders & attested copies of percentage of works completed or part thereof.

- ii. Statement showing assessed available Bid Capacity.
- iii. The declaration cum indemnity bond of Rs.500/- stamp paper as per the proforma annexed in 'Annexure B & C'
- iv. All other Proformas & Annexures duly filled & signed.
- v. Litigation history

Note:- Bidders shall submit the undertaking for machinery/equipment/vehicle capability and other undertakings as such on a single Rs.500/- stamp paper.

- i. The tenderers shall upload work plan as per the following outline:
 1. Organizational set up envisage by the contractors.
 2. Equipment/Vehicle proposed to be deployed for this work.
 3. Office proposed to be set up in MMR region (if not at Present).
 4. A note on how the whole work will be carried out (work plan including methodology).
 5. Quality management plan.
 6. All the activities included in the Scope of Work shall be covered in the work plan.

Note:

- i. The successful bidder shall submit valid registration certificate under E.S.I.C., Act 1948, if the tenderer has more than 10 employees /persons on his establishment (in case of production by use of energy) and 20 employees/persons on his establishment (in case of production without use of energy) to MCGM as and when demanded. In case of less employees/persons mentioned above then the successful bidder has to submit an undertaking to that effect on Rs. 500 stamp paper as per circular u/no. CA/FRD/I/65 of 30.03.2013.
- ii. The successful bidder shall submit valid registration certificate under E.P.F. & M.P., Act 1952, if tenderer has more than 20 employees/persons on his establishment, to MCGM as and when demanded. In case if the successful bidder has less employees/persons mentioned above then the successful bidder has to submit an undertaking to that effect on Rs. 500 stamp paper as per circular u/no. CA/FRD/I/44 of 04.01.2013.

Note:

- If it is found that the tenderer has not submitted required documents in Packet “B” then, the shortfalls will be communicated to the tenderer through e-mail only and compliance required to be made within a time period of **three working days** otherwise they will be treated as non-responsive.

PACKET – C

For Packet ‘C’ tenderer(s) will fill data in ‘Item Data Tab’ in Service Line Item via Details and quotes his item wise rate.

Note:

- 1. The rate analysis of major items shall be submitted by L1 and L2 bidder after demand notification by e-mail to bidders by concerned Dy.Ch.Eng. The format for rate analysis is annexed at Annexure D.**
- 2. The contract will be awarded to lowest responsive bidder.**

BID SECURITY OR EMD

- The Bidder shall furnish, as part of the Bid, Bid Security/EMD, in the amount specified in the Bid Data Sheet. This bid security shall be in favor of the authority mentioned in the Bid Data Sheet and shall be valid till the validity of the bid.
- The tenderers shall pay the EMD online instead paying the EMD at any of the CFC centers in BMC Ward Offices.
- Any bid not accompanied by an acceptable Bid Security and not secured as indicated in sub-clause mentioned above, shall be rejected by the Employer as non-responsive.

The Bid Security/EMD of the successful bidder will be discharged when the bidder has signed the agreement and furnished the required Security Deposits.

- The Bid Security/ EMD and ASD of L-2 and other higher bidders (L-3, L-4, etc.) shall be refunded immediately after opening of financial bid.
 - The Bid Security may be forfeited:
 - a) If the Bidder withdraws the Bid after bid opening (opening of technical qualification part of the bid during the period of Bid validity;
 - b) In the case of a successful Bidder, if the Bidder fails within the specified time limit to:
 - i. sign the Agreement; and/or
 - ii. Furnish the required Security Deposits.
1. The cases wherein if the shortfalls are not complied by a contractor, will be informed to Registration and Monitoring Cell. Such non-submission of documents will be considered as 'Intentional Avoidance' and if three or more cases in 12 months are re-reported, shall be viewed seriously and disciplinary action against the defaulters such as banning/de-registration, etc. shall be taken by the registration cell with due approval of the concerned AMC.
 2. No rejections and forfeiture shall be done in case of curable defects. For non-curable defects the 10% of EMD shall be forfeited and bid will be liable for rejection.

Note:

A) Curable Defect shall mean shortfalls in submission such as:

- a. Non-submission of following documents,**
 - i. Valid Registration Certificate**
 - ii. Valid Bank Solvency**
 - iii. Goods & Service Tax Certificate (GST)**
 - iv. Certified Copies of PAN documents and photographs of individuals, owners, etc**
 - v. Partnership Deed and any other documents**
 - vi. Undertakings as mentioned in the tender document.**
- b. Wrong calculation of Bid Capacity.**
- c. No proper submission of experience certificates and other documents, etc.**

B) Non-curable Defect shall mean:

- a. In-adequate submission of EMD amount,**
- b. In-adequacy of technical and financial capacity with respect to Eligibility criteria as stipulated in the tender.**

BID VALIDITY

- **Bids shall remain valid for a period of not less than one eighty (180) days after the deadline date for bid submission specified in Bid Data Sheet. A bid valid for a shorter period shall be rejected by the Employer as non-responsive.**
- In exceptional circumstances, prior to expiry of the original time limit, the Employer may request that the bidders may extend the period of validity for a specified additional period. The request and the bidders' responses shall be made in writing or by cable. A bidder may refuse the request without forfeiting his Bid Security. A bidder agreeing to the request will not be required or permitted to modify his bid, but will be required to extend the validity of his bid security for a period of the extension.

SECURITY DEPOSIT

i. Security Deposit

The security deposit shall mean and comprise **of Contract Deposit**

Contract Deposit - The successful tenderer, here after referred to as the contractor shall pay an amount in the form of Cash or Government Securities or Fixed Deposit Receipts or Bank Guarantee or Demand Draft / Bank Pay Order from a Nationalized / Scheduled Commercial Bank approved by BMC, drawn in favour of “Brihanmumbai Municipal Corporation”, payable at Mumbai, equal to five (5) percent of the contract sum within thirty days from the date of issue of letter of acceptance.

Additional Security Deposit (ASD):

In addition to contract deposit the successful contractor has to pay additional security deposit within 30 days from date of issue of LOA. This additional security deposit will be applicable when the bid price will be below 12% of the estimated cost. The Additional Security Deposit will be calculated as below:-

Additional Security deposit

$$= \mathbf{X/100 \times \text{office estimated cost}}$$

Where X= percentage of rebate quoted above 12%.

This additional security deposit shall be paid in the form of Government Securities or Fixed Deposit Receipts or Bank Guarantee or Demand Draft/ Bank Pay Order from a Nationalized/ Scheduled Commercial Bank approved by BMC.

Refund of Contract Deposit

The Contract Deposit shall be released within 30 days after completion of contract period subject to no recoveries are pending against the said work,

provided that the Engineer is satisfied that there is no demand outstanding against the Contractor.

***Note:**

- i.** It shall be clearly mentioned that the BG shall be applicable for individual work/contract and clubbing of various contracts of the said contractor will not be allowed. In case of obtaining Bank Guarantee, it is necessary to mention that the same shall be valid till certification of final bill subject to no recoveries is pending against the said work.
- ii.** It shall be the responsibility of the bidder to keep the submitted B.G. “VALID” for the stipulated time period in the tender. Normally the BG is validated by the Bank for one year hence the successful bidder shall get it re validated before it expiry. If the same is not re validated before expiry, the BG will be encashed.
- iii.** Bank Guarantee should be issued by way of General Undertaking and Guarantee issued on behalf of the Contractor by any of the Nationalized or Scheduled banks or branches of foreign banks operating under Reserve Bank of India regulations located in Mumbai up to Virar & Kalyan. List of approved Banks is appended at the end of Instructions to Bidders (ITB). The Bank Guarantee issued by branches of approved Banks beyond Kalyan and Virar can be accepted only if the said Bank Guarantee is countersigned by the Manager of a Regional Branch of the same bank within the Mumbai City Limit categorically endorsing thereon that the said Bank Guarantee is binding on the endorsing Branch of the Bank or the Bank itself within Mumbai Limits and is liable to be enforced against the said Branch of the Bank or the bank itself in case of default by the Contractors furnishing the Bank Guarantee. The Bank Guarantee shall be renewed as and when required and/or directed from time to time until the Contractor has executed and completed the works and remedied any defects therein.

B. Legal + Stationary Charges: (As per applicable circular)

Successful tenderer shall pay the Legal Charges +Stationary charges as below or as per latest applicable Circular at the time of award of contract and applicable 18 % GST (currently the amounts mentioned here are as per circular of legal department u/no. 26206 dtd 31.08.2023).

Contract Value		Legal + Stationary Charges
from	Up to Rs. 50,000	Nil
	Rs.500001/- upto Rs. 1,00,00,000/-	At the rate of 0.10 % of the contract value (regarding the subsequent rounding of such amount to the next hundredth) + 18 % GST (Minimum of Rs. 1000 + 18 % GST & Maximum of Rs. 10,000 + 18 % GST)
	Rs. 1,00,00,001 upto Rs. 10,00,00,000/-	[Rs. 10,000 for the contract value of Rs. 1,00,00,000 + At the rate of 0.05 % on the contract value exceeding of Rs. 1,00,00,000 upto Rs. 10,00,00,000/- (regarding the subsequent rounding of such amount to the next hundredth)] + 18 % GST
	Rs. 10,00,00,001/- upto Any limit	[Rs. 55,000 for the contract value of Rs. 10,00,00,000 + At the rate of 0.01 % on the contract value exceeding of Rs. 10,00,00,000/- upto Any limit] + 18 % GST

iv. Stamp Duty: (As per applicable circular)

It shall be incumbent on the successful tenderer to pay stamp duty on the contract.

- i. As per the provision made in Article 63, Schedule I of Bombay Stamp Act 1958, stamp duty is payable for “works contract” that is to say, a contract for works and labour or services involving transfer of property in goods (whether as goods or in some other form) in its execution and includes a sub-contract, as under :

A	Where the amount or value set forth in such contract does not exceed rupees ten lakh.	Five Hundred rupees stamp duty
B	Where it exceeds rupees ten lakhs	Five hundred rupees plus 0.1% of amount above rupees ten lakhs subject to the maximum of Rs. twenty five Lakhs stamp duty.
C	Stamp duty on BG	0.5% on amount of BG paid by successful contractor.

- ii. The successful bidder shall enter into a contract agreement with B.M.C within 60 days from the date of issue of Work Order and the same should be adjudicated for payment of Stamp Duty by the successful bidder.
- iii. Further shortfall if any, in amount of stamp duty paid as against prescribed amount for the documents executed in Mumbai City & Mumbai Suburban District be recovered from the concerned work contractors and to deposit the deficit or unpaid Stamp Duty and penalty by two separate Demand Draft or Pay Order in favour of “Superintendent of Stamp, Mumbai” within 15 days from intimation thereof.
- iv. All legal charges and incidental expenses in this respect shall be borne and paid by the successful tenderer.
- v. All above mentioned values are as applicable while inviting the tender. However the contractor has to pay the stamp duty charges as per the latest applicable circular at the time of award of contract.

IMPORTANT DIRECTIONS

1. All the information uploaded shall be supported by the corroborative documents in absence of which the information uploaded will be considered as baseless and not accepted for qualification criteria. All the documents shall be uploaded with proper pagination. The page No. shall be properly mentioned in the relevant places.

The information shall be uploaded in the sequence as asked for with proper indexing etc. The Bidder shall be fully responsible for the correctness of the information uploaded by him.

2. Applicants/Bidders shall refer [portal.mcgm.gov.in\](http://portal.mcgm.gov.in/tenders)tenders for “The Manual of Bid- Submission for Percentage Rate/Item Rate Tender

Document.” The detail guidelines for creation and submission of bid are available in the referred document.

Any queries or request for additional information concerning this TENDER shall be submitted by e-mail to [dycheswmplanning.swm@mcgm.gov.in/](mailto:dycheswmplanning.swm@mcgm.gov.in) ee1swm.pl@mcgm.gov.in. The subject shall clearly bear the following identification/title: **"Queries/Request for Additional Information: TENDER for “Subject of the tender”** Any changes in mail ID will be intimated on the portal.

3. In case of **Equal Rate of lowest bidders (L1)**, the allotment of work shall be done by giving **48 hrs (2 working days)** from the day of opening of packet C on same BID-Document number **for re-quoting** and such development needs to done by IT department in MCGM’s SRM system. **Till such development is made; ‘Sealed Bids’ shall be called from the bidders quoting the same rates i.e. L1.**

In case of **equal rate of lowest bidders** is obtained **even after re-quoting**, then the successful bidder will be decided by **lottery system** by Ch.Eng.(SWM).

SECTION 7

SCOPE OF WORK

Scope of work:

The refuse collection storage facility at various locations in wards are used for temporary storage of refuse which are collected by the sweepers by sweeping the roads, the litter thrown by the public and the refuse collected from the nearby area.

The tender aims at inviting knowledgeable and resourceful contractor for Manufacturing & Supply of refuse collection storage facility and enclosures at various locations in the wards of Mumbai.

For more details please refer **Section 10- Specification.**

SECTION 8

Bill of Quantities

SCHEDULE (BILL) OF QUANTITIES AND RATES

Subject:- Manufacturing & Supply of refuse collection storage facility and enclosures at various locations in the wards of Mumbai.

Sr. No.	Description	Quantity	Unit	Rate per system (Inclusive of all taxes, Duties, Levies etc.) (Rs.)	Total Cost (Rs.)
1	Part A Manufacturing & Supply of refuse collection storage facility at various locations in wards as per attached technical specifications, requirements, terms & conditions	1300	Nos		
2	Part B Manufacturing & Supply of SS structure (enclosure) at 1.1 Cu. M garbage collection spot along with foundation work as per attached technical specifications, requirements, terms & conditions.	100	Nos		
Total Contract Cost (In Rs.) (Part A+ Part B)					

Note- 1) This BOQ is for representation purpose only. Bidder has to quote the rates in online system only.

2) The rate analysis shall be submitted by L1 & L2 bidder only after demand notification by email to the bidders by concerned Dy.Ch.Eng. The format for rate analysis is annexed at Annexure 'D'.

SECTION 9
General Conditions of
Contract

General Conditions of Contract

A. General

1. Definitions

1.1 Terms which are defined in the Contract Data are not also defined in the Conditions of Contract but keep their defined meanings. Capital initials are used to identify defined terms.

The “Contract” shall mean the tender and acceptance thereof and the formal agreement if any, executed between the Contractor, Commissioner and the Corporation together with the documents referred to therein including these conditions and appendices and any special conditions, the specifications, designs, drawings, price schedules, bills of quantities and schedule of rates. All these documents taken together shall be deemed to form one Contract and shall be complementary to one another.

The Contract Data defines the documents and other information which comprise the Contract.

The Bidder is a person or corporate body who has desired to submit Bid to carry out the Works, till the tender process is concluded.

The “Contractor” shall mean the individual or firm or company, or JV firms whether incorporated or not, whose tender has been accepted by the employer and the legal successor of the individual or firm or company.

The Contractor's Bid is the completed bidding document submitted by the bidder to the Employer.

The “Contract Sum” means the sum named in the letter of acceptance including Physical contingencies subject to such addition thereto or deduction there-from as may be made under the provisions hereinafter contained.

Note: The contract sum shall include the following –

- For item rate contracts, the cost of the work arrived at after finalisation of the quantities shown in schedule of items / quantities by the item rates quoted by the tenderer for various items and summation of the extended cost of each item.
- In case of lump sum contract, the sum for which tender is accepted.

- Special discount / rebate / trade discount offered by the tenderer if any and accepted by the Corporation. Additions or deletions that are accepted after opening of the tenders.

The “Contract Cost” means the Contract Sum. This cost shall be included in the letter of acceptance.

A Defect is any part of the Works not completed in accordance with the Contract.

Drawings means all the drawings, calculations and technical information of a like nature provided by the Engineer to the Contractor under the Contract and all drawings, calculations, samples, patterns, models, operation & maintenance manual and other technical information of like nature submitted by the Contractor and approved by the Engineer.

The Authority shall mean Brihanmumbai Municipal Corporation (BMC)

The “Employer” shall mean the Brihanmumbai Municipal Corporation (BMC)/ Municipal Commissioner for Brihanmumbai, for the time being holding the said office and also his successors and shall also include all “Additional Municipal Commissioners, Director (Engineering Services & Projects)” and the Deputy Municipal Commissioner, to whom the powers of Municipal Commissioner, have been deputed under Section 56 and 56B of the Mumbai Municipal Corporation Act.

The Engineer in-charge shall mean the Executive Engineer in executive charge of the works and shall include the superior officers of the Engineering department i.e. Dy.Ch.Eng/Ch.Eng. and shall mean and include all the successors in BMC

The Engineer's Representative shall mean the Assistant Engineer, Sub-Engineer/Jr. Engineer in direct charge of the works and shall include Sub Eng./ Jr. Eng of Civil section/ Mechanical section/ Electrical section appointed by BMC.

The “Engineer” shall mean the City Engineer / the Hydraulic Engineer / the Chief Engineer / the Special Engineer, appointed for the time being or any other officer or officers of the Municipal Corporation who may be authorized by the commissioner to carry out the functions of the City Engineer / the Hydraulic Engineer / the Chief Engineer / the Special

Engineer or any other competent person appointed by the employer and notified in writing to the Contractor to act in replacement of the Engineer from time to time.

Contractor's equipment means all appliances and things whatsoever nature required for the execution and completions of the Works and the remedying of any defects therein, but does not include plant material or other things intended to form or forming part of the Permanent Works.

The Initial Contract Price is the Contract Price listed in the Employer's Letter of Acceptance.

The Intended Completion Date is the date on which it is intended that the Contractor shall complete the works. The Intended Completion Date is specified in the Contract Data. The Intended Completion Date may be revised only by the Engineer by issuing an extension of time.

Materials are all supplies, including consumables, used by the Contractor for incorporation in the Works and works of routine maintenance.

Plant is any integral part of the Works that shall have a mechanical, electrical, electronic, chemical, or biological function.

Routine Maintenance is the maintenance of activities of the completed structure for seven years as specified in the Contract Data.

The "Site" shall mean the land and other places including water bodies more specifically mentioned in the special conditions of the tender, on, under in or through which the permanent works or temporary works are to be executed and any other lands and places provided by the Municipal Corporation for working space or any other purpose as may be specifically designated in the contract as forming part of the site.

Site Investigation Reports are those that were included in the bidding documents and are reports about the surface and subsurface conditions at the Site.

"Specification" shall mean the specification referred to in the tender and any modification thereof or addition or deduction thereto as may from time to time be furnished or approved in writing by the Engineer.

The Start Date/Commencement Date It is the date when the Contractor shall commence execution of the Works.

Variation means a change to the:-

- i) Specification and /or Drawings (if any) which is instructed by the Employer.
- ii) Scope in the Contract which is instructed by the Employer.
- iii) Price in the Contract which is instructed by the Employer.

The Works, as defined in the Contract Data, are what the Contract requires the Contractor to carry out the work as per specifications.

Jurisdiction: In case of any claim, dispute or difference arising in respect of a contract, the cause of action thereof shall be deemed to have arisen in Mumbai and all legal proceedings in respect of any claim, dispute or difference shall be instituted in a competent court in the City of Mumbai only.

2. Interpretation

2.1 In interpreting these Conditions of Contract, singular also means plural, male also means female or neuter, and the other way around. Headings have no significance. Words have their normal meaning under the language of the Contract unless specifically defined. The Engineer will provide instructions clarifying queries about these Conditions of Contract.

2.2 If sectional completion is specified in the Contract Data, references in the Conditions of Contract to the Works, the Completion Date, and the Intended Completion Date apply to any Section of the Works (other than references to the Completion Date and Intended Completion Date for the whole of the Works).

2.3 The documents forming the Contract shall be interpreted in the following documents: (1) Agreement, (2) Letter of Acceptance, (3) Notice to Proceed with the Work, (4) Contractor's Bid, (5) Contract Data, (6) Special Conditions of Contract Part (7) General Conditions of Contract Part I, (8) Specifications, (9) Drawings, (10) Bill of Quantities, and (11) Any other document listed in the Contract Data.

3 . Engineer's Decisions

3.1 Except where otherwise specifically stated, the Engineer will decide contractual matters between the Employer and the Contractor in the role representing the Employer. However, if the Engineer is required under the

rules and regulations and orders of the Employer to obtain prior approval of some other authorities for specific actions, he will so obtain the approval, before communicating his decision to the Contractor.

3.2 Except as expressly stated in the Contract, the Engineer shall not have any authority to relieve the Contractor of any of his obligations under the contract.

4. Delegation

4.1 The Engineer, with the approval of the Employer, may delegate any of his duties and responsibilities to other person(s), except to the Adjudicator, after notifying the Contractor, and may cancel any delegation after notifying the Contractor.

5. Communications

All certificates, notices or instructions to be given to the Contractor by Employer/ Engineer shall be sent on the address or contact details given by the Contractor of Bid. The address and contact details for communication with the Employer/ Engineer shall be as per the details given in Contract Data. Communications between parties that are referred to in the conditions shall be in writing. The Notice sent by facsimile (fax) or other electronic means shall be effective on confirmation of the transmission. The Notice sent by Registered post or Speed post shall be effective on delivery or at the expiry of the normal delivery period as undertaken by the postal service.

6. Subcontracting

Subletting shall not be allowed. If subletting is observed during the course of the contract, it shall result in the termination of contract at risk & cost of the successful bidder.

7. Other Contractors

7.1 The Contractor shall cooperate and share the Site with other Contractors, public authorities, utilities, and the Employer between the dates given in the Schedule of Other Contractors, as referred to in the Contract Data. The Contractor shall also provide facilities and services for them as described in the Schedule. The Employer may modify the Schedule of Other Contractors, and shall notify the Contractor of any such modification.

7.2 The Contractor should take up the works in convenient reaches as decided by the Engineer to ensure there is least hindrance to the smooth flow and safety of traffic including movement of vehicles and equipment of other Contractors till the completion of the Works.

8. Personnel

8.1 The Contractor shall employ for the work and routine maintenance the key personnel including technical personnel named in the Contract Data or other personnel approved by the Engineer. The Engineer will approve any proposed replacement of technical personnel only if their relevant qualifications and abilities are substantially equal to those of the personnel stated in the Contract Data.

8.2 The Contractor's personnel shall appropriately be qualified, skilled and experienced in their respective trades or occupations. The Engineer shall have authority to remove, or cause to be removed, any person employed on the site or works, who carries out duties incompetently or negligently and persists in any conduct which is prejudicial to safety, health or the protection of the environment.

8.3 If the Engineer asks the Contractor to remove a person who is a member of the Contractor's staff or work force, stating the reasons, the Contractor shall ensure that the person leaves the Site within seven days and has no further connection with the Works in the Contract.

8.4 The Contractor shall not employ any retired Gazetted officer who has worked in the Engineering Department of the BMC /State Government and has either not completed two years after the date of retirement or has not obtained BMC/State Government's permission to employment with the Contractor.

9. Employer's and Contractor's Risks

The Employer carries the risks which this Contract states are Employer's risks, and the Contractor carries the risks which this Contract states are Contractor's risks.

10. Employer's Risks

10.1 The Employer is responsible for the excepted risks which are (a) in so far as they directly affect the execution of the Works in the Employer's country, the risks of war, invasion, act of foreign enemies, rebellion,

revolution, insurrection or military or usurped power, civil war, riot, commotion or disorder (unless restricted to the Contractor's employees) and contamination from any nuclear fuel or nuclear waste or radioactive toxic explosive, or (b) a cause due solely to the design of the Works, other than the Contractor's design.

11. Contractor's Risks

11.1 All risks of loss of or damage to physical property and of personal injury and death which arise during and in consequence of the performance of the Contract other than the excepted risks, referred to in clause 11.1, are the responsibility of the Contractor.

12. Insurance

The contractor has to provide all relevant insurances for the machinery & staff as per the governing laws. All expenses towards this shall be borne only by the contractor. BMC shall be indemnified & absolved arising out of any issues & claims etc. out of this.

12.1 Contractor shall take necessary insurance policy, policies so as to provide adequate insurance cover for execution of the awarded contract work from the Director of Insurance Maharashtra State Mumbai only. It's postal address for correspondences 264 MAHADA, Opp. Kalanagar Bandra (E) Mumbai-400051 (Tel No. 6438403) (Fax No. 6438690) Insurance policy / policies taken out from any other company will not be accepted. The Contractor should produce the documents of insurance done before payment of 1st. bill. If the contractor fails to produce the documents of insurance. One percent of the contract amount will be recovered from the contractors 1st bill and remitted towards insurance premium.

13. Site Investigation Reports

The Contractor, in preparing the Bid, may rely, at his own risk, on any Site Investigation Reports referred to in the Contract Data, supplemented by any other information available to him, before submitting the bid.

14. Queries about the Contract Data

The Engineer will clarify queries on the Contract Data.

15. Contractor to carry out the Works and Undertake Maintenance (if specified in the tender)

15.1 The Contractor shall carry out the Works in accordance with the Specifications and Drawings and as per instructions of the Engineer.

15.2 The Contractor shall carry out the works with maximum input of machinery required to ensure the quality of works as per specifications. The Contractor shall deploy the equipment and machinery as required in the contract.

15.3 The Contractor shall take all reasonable steps to protect the environment on and off the Site and to avoid damage or nuisance to persons or to property of the public or others resulting from pollution, noise or other causes arising as a consequence of his methods of operation.

During continuance of the contract, the Contractor shall abide at all times by all existing enactments on environmental protection and rules made there under, regulations, notifications and byelaws of the State or Central Government, or local authorities and any other law, bye-law, regulations that may be passed or notification that may be issued in future by the State or Central Government or the local authority. Salient features of some of the major laws that are applicable are given below:

- The Water (Prevention and Control of Pollution) Act, 1974, this provides for the prevention and control of water pollution and the maintaining and restoring of wholesomeness of water. 'Pollution' means such contamination of water or such alteration of the physical, chemical or biological properties of water or such discharge of any sewage or trade effluent or of any other liquid, gaseous or solid substance into water (whether directly or indirectly) as may, or is likely to, create a nuisance or render such water harmful or injurious to public health or safety, or to domestic, commercial, industrial, agricultural or other legitimate uses, or to the life and health of animals or plants or of aquatic organisms.
- The Air (Prevention and Control of Pollution) Act, 1981, this provides for prevention, control and abatement of air pollution. 'Air Pollution' means the presence in the atmosphere of any 'air pollutant', which means any solid, liquid or gaseous substance (including noise) present in the atmosphere in such concentration as may be or tend to be

injurious to human beings or other living creatures or plants or property or environment.

- The Environment (Protection) Act, 1986, this provides for the protection and improvement of environment and for matters connected therewith, and the prevention of hazards to human beings, other living creatures, plants and property. 'Environment' includes water, air and land and the inter-relationship which exists among and between water, air and land, and human beings, other living creatures, plants, micro-organism and property.
- The Public Liability Insurance Act, 1991, This provides for public liability insurance for the purpose of providing immediate relief to the persons affected by accident occurring while handling hazardous substances and for matters connected herewith or incidental thereto. Hazardous substance means any substance or preparation which is defined as hazardous substance under the Environment (Protection) Act 1986, and exceeding such quantity as may be specified by notification by the Central Government.
- The Solid Waste Management Rules-2016 This provides for management & handling of solid Waste
- The Constructions & Demolition Waste Rules, 2016.

16. The Works to be completed by the Intended Completion Date

16.1 The Contractor may commence execution of the Works on the Start Date and shall carry out the Works, if specified in the tender, in accordance with the Programme submitted by the Contractor, as updated with the approval of the Engineer, and complete them by the Intended Completion Date.

17. Approval by the Engineer

The Contractor shall submit Specifications and Drawings showing the proposed Temporary Works to the Engineer, who is to approve them if they comply with the Specifications and Drawings.

The Contractor shall be responsible for design and safety of Temporary Works. The Engineer's approval shall not alter the Contractor's responsibility for design and safety of the Temporary Works.

The Contractor shall obtain approval of third parties to the design of the Temporary Works, where required.

All Drawings prepared by the Contractor for the execution of the temporary or permanent Works, are subject to prior approval by the Engineer before their use.

18. Safety

18.1 The Contractor shall be responsible for the safety of all activities on the Site. He shall comply with all applicable safety requirements and take care of safety of all persons entitled to be on the site and the works. He shall use reasonable efforts to keep the site and the works, during execution of works, clear of unnecessary obstruction so as to avoid danger to the persons.

The contractor shall provide all safety gear to his employees as specified in the specification of Project.

18.2 First Aid Facilities: -

- i. At every work place successful bidder shall provide and maintain first aid box of adequate capacity and it should be easily accessible during working hours
- ii. The first-aid box shall be distinctly marked with a red cross on white back ground.
- iii. Adequate arrangements shall be made for immediate recoument of the equipment when necessary.
- iv. Nothing except the prescribed contents shall be kept in the First-aid box.
- v. The first-aid box shall be kept in charge of a responsible person who shall always be readily available during the working hours of the work place.
- vi. A person in charge of the First-aid box shall be a person trained in First-aid treatment.

19. Discoveries

Anything of historical or other interest or of significant value unexpectedly discovered on the Site shall be the property of the Employer. The Contractor shall notify the Engineer of such discoveries and carry out the Engineer's instructions for dealing with them.

20. Possession of the Site

~~—————The Employer shall handover complete or part possession of the site to the Contractor 7 days in advance of construction programme. At the start of the work, the Employer shall handover the possession of at least 75% of the site free of all encumbrances, the remaining 25 % of the possession as per contractor's construction programme.~~

21. Access to the Site

The Contractor shall allow access to the Site and to any place where work in connection with the Contract is being carried out, or is intended to be carried out to the Engineer and any person/persons/agency authorized by: a. The Engineer b. The Employer or authorized by the Employer.

22. Instructions

22.1 The Contractor shall carry out all instructions of the Engineer, which comply with the applicable laws where the Site is located.

22.2 The Contractor shall permit the appointed and/or authorized persons to inspect the Site and/or accounts and records of the Contractor and its subcontractors relating to the performance of the Contract, and to have such accounts and records audited by auditors appointed, if so required. The Contractor's attention is invited to Clause of 'Fraud and Corruption', which provides, inter alia, that acts intended to materially impede the exercise of the inspection and audit rights provided for under the Clause & constitute a obstructive practice subject to contract termination.

22.3 Engineer to have power to issue further drawings or instructions:

The Engineer shall have the power and authority from time to time and at all times to give such further instructions and directions as may appear to him necessary or proper for the guidance of the contractor and the good and sufficient execution of the works according to terms of the specifications and Contractor shall receive, execute, obey and be bound by the same, according to the true intent and meaning thereof, as fully and effectually as though the same had accompanied or had been mentioned or referred to in the specification, and contemplated by the specifications, or may order any of the works contemplated thereby to be omitted, with or without the substitution of any other works in lieu thereof, or may order any work or any

portion of work executed or partially executed, to be removed, changed or altered, added if needful, may order that other works shall be substituted instead thereof and difference of expense occasioned by any such diminution or alteration so ordered and directed shall be added to or deducted from the amount of this Contract, as provided under condition no.10(a) hereinafter.

No work which radically changes the original nature of the Contract shall be ordered by the Engineer and in the event of any deviation being ordered which in the opinion of the Contractor changes the original nature of Contract he shall nevertheless carry it out and disagreement as to the nature of the work and the rate to be paid therefore shall be resolved.

The time for completion of the Works, shall be in event of any deviations resulting in additional cost over the contract price being ordered, be extended or reduced reasonably by the Engineer. The Engineer's decision in this case shall be final.

B. Time Control

23. Programme

Within the time stated in the Contract Data, the Contractor shall submit to the Engineer for approval a Programme, including Environment Management Plan showing the general methods, arrangements, order, and timing for all the activities in the Works, along with monthly cash flow forecasts for the construction of works/ subject work.

After the completion of the construction works, the programme for the Routine Maintenance Work, showing the general methods, arrangements, order and timing for all the activities involved in the Routine Maintenance will also be submitted by the Contractor to the Engineer for approval if specified in the tender. The programme for Routine Maintenance will be submitted in each year for the period of Maintenance.

The Contractor shall submit the list of equipment and machinery being brought to site, the list of key personnel being deployed, the list of machinery/ equipments being placed in field laboratory and the location of field laboratory along with the Programme. The Engineer

shall cause these details to be verified at each appropriate stage of the programme.

An update of the Programme shall be a programme showing the actual progress achieved on each activity and the effect of the progress achieved on the timing of the remaining Works, including any changes to the sequence of the activities.

The Contractor shall submit to the Engineer for approval an updated Programme at intervals no longer than the period stated in the Contract Data. If the Contractor does not submit an updated Programme within this period, the Engineer may withhold the amount stated in the Contract Data from the next payment certificate and continue to withhold this amount until the next payment after the date on which the overdue Programme has been submitted.

The Engineer's approval of the Programme shall not alter the Contractor's obligations. The Contractor may revise the Programme and submit it to the Engineer again at any time. A revised Programme shall show the effect of Variations and Compensation Events.

24. Extension Of Time In Contracts :

Subject to any requirement in the contract as to completion of any portions or portions of the works before completion of the whole, the contractor shall fully and finally complete the whole of the works comprised in the contract (with such modifications as may be directed under conditions of this contract) by the date entered in the contract or extended date in terms of the following clauses:

a) Extension attributable to BMC

- i. Extension Due To Modification: If any modifications have been ordered which in the opinion of the Engineer have materially increased the magnitude of the work, then such extension of the contracted date of completion may be granted as shall appear to the Engineer to be reasonable in the circumstances, provided moreover that the Contractor shall be responsible for requesting such extension of the date as may be considered necessary as soon as the cause thereof shall arise and in any

case should not be less than 30 days before the expiry of the date fixed for completion of the works.

ii. **Extension For Delay Due To BMC:** In the event of any failure or delay by BMC to hand over the Contractor possession of the lands necessary for the execution of the works or to give the necessary notice to commence the works or to provide the necessary drawings or instructions or any other delay caused by the MCGM due to any other cause whatsoever, then such failure or delay shall in no way affect or vitiate the contract or alter the character thereof or entitle the contractor to damages or compensation therefore, but in any such case, the MCGM may grant such extension(s) of the completion date as may be considered reasonable.

Note: For extension of time period as governed in (i) and (ii) above, any modifications in design/drawings, specifications, quantities shall be needed to be justified with recorded reasons with approval of Ch.Eng. for not anticipating the same while preparing estimates and draft tender.

(b) Extension Of Time For Delay Due To Contractor : The time for the execution of the work or part of the works specified in the contract documents shall be deemed to be the essence of the contract and the works must be completed no later than the date(s) / the programme for completion of work as specified in the contract. If the contractor fails to complete the works within the time as specified in the contract for the reasons other than the reasons specified in above as (a.i) and (a.ii), the BMC may, if satisfied that the works can be completed by the contractor within reasonable short time thereafter, allow the contractor for further extension of time as the Engineer may decide. On such

extension the BMC will be entitled without prejudice to any other right and remedy available on that behalf, to recover the compensation as governed by Clause 8(e) of GCC.

For the purpose of this Clause, the contract value of the works shall be taken as value of work as per contract agreement including any supplementary work order/contract agreement issued.

Further, competent authority while granting extension to the currency of contract under Clause (b) of as above may also consider levy of penalty, as deemed fit based on the merit of the case. Also, the reasons for granting extension shall be properly documented.

25. Delays Ordered by the Engineer

The Engineer may instruct the Contractor to delay the start or progress of any activity within the Works. Delay/delays totalling more than 30 days will require prior written approval of the DMC/AMC.

26. Management Meetings

26.1 The Engineer may require the Contractor to attend a management meeting. The business of a management meeting shall be to review the plans for progress of the Works.

26.2 The Engineer shall record the business of management meetings and provide copies of the record to those attending the meeting. The responsibility of the parties for actions to be taken shall be decided by the Engineer either at the management meeting or after the management meeting and stated in writing to all those who attended the meeting.

C. Quality Control

28. Identifying Defects

28.1 The Engineer shall check the Contractor's work and notify the Contractor of any Defects that are found. Such checking shall not affect the Contractor's responsibilities. The Engineer may instruct the Contractor to search for a Defect and test any work that the Engineer considers may have a Defect.

28.2 The Contractor shall permit the Employer's technical person(s) to check the Contractor's work and notify the Engineer and Contractor if any defects that are found.

30. Correction of Defects

30.1 (a) The Engineer shall give notice to the Contractor of any Defects with respect to the equipment/vehicle/work during the contract period.

(b) Every time notice of Defect/Defects is given, the Contractor shall correct the notified Defect/Defects within the duration of time specified by the Engineer's notice.

(c) The Engineer may issue notice to the Contractor to carry out removal of defects or deficiencies, if any, noticed in his inspection, or brought to his notice. The Contractor shall remove the defects and deficiencies within the period specified in the notice and submit to the Engineer a compliance report.

31. Uncorrected Defects and Deficiencies

If the Contractor has not corrected a Defect under clause and deficiencies in works, to the satisfaction of the Engineer, within the time specified in the Engineer's notice, the Engineer will assess the cost of having the Defect or deficiency corrected, and the Contractor shall pay this amount, on correction of the Defect or deficiency by another agency.

D. Cost Control

32. Variations

The Engineer shall, having regard to the scope of the Works and the sanctioned estimated cost, have power to order, in writing, Variations within the scope of the Works he considers necessary or advisable during the progress of the Works. Such Variations shall form part of the Contract and the Contractor shall carry them out and include them in updated Programmes produced by the Contractor. Oral orders of the Engineer for Variations, unless followed by written confirmation, shall not be taken into account.

33. Payments for Variations

33.1 Even if rates for Variation items are not specified in the Bill of Quantities, the Contractor shall carry out such work at the same rate.

33.2 The rate for Extra/Excess shall be governed by clause 10.A of Standard General Condition of Contract.

34. Cash Flow Forecasts

When the Programme is updated, the Contractor shall provide the Engineer with an updated cash flow forecast.

35. Payment Certificates

The payment to the Contractor will be as follows:

(a) A bill shall be submitted by the Contractor monthly and the Engineer In-charge shall take or cause to be taken requisite measurement for the purpose of having the same verified and the claim, so far as it is admissible, shall be adjusted, if possible, within 30 days from the presentation of the bill.

(b) The Engineer shall check the Contractor's statement within 14 days and certify the amount to be paid to the Contractor.

(c) The value of work executed shall be determined, based on VTMS/ WMS & such IT related systems developed by the BMC.

(d) The value of work executed shall comprise the value of the quantities of the items in the Bill of Quantities completed.

(e) The value of work executed shall also include the valuation of Variations and Compensation Events.

(f) The Engineer may exclude any item certified in a previous certificate or reduce the proportion of any item previously certified in any certificate in the light of later information.

(g) The contractor shall submit all bills on the printed forms at the office of AE (SWM) of the ward. The charges to be made in the bills shall always be entered at the rates specified in tender.

36. Payments

36.1 Payments shall be adjusted for deductions for advance payments, retention, security deposit, other recoveries in terms of the Contract and taxes at source, as applicable under the law. The Employer shall pay the Contractor the amounts certified by the Engineer within 15 days of the date of each certificate.

36.2 All sums payable by a contractor by way of compensation under any of these conditions, shall be considered as a reasonable compensation to be applied to the use of BMC without reference to the actual loss or damage sustained and whether any damage has or has not been sustained.

36.3 No payment shall be made for any work estimated to cost less than Rupees One Thousand till after the whole of work shall have been completed and the certificate of completion given. But in the case of works estimated to cost more than Rs. One Thousand, the contractor shall on submitting a monthly bill therefore be entitled to receive payment proportionate to the part of the work than approved and passed by the Engineer In-charge, whose certificate of such approval and passing of the sum so payable shall be final and conclusive against the contractor. All such intermediate payments shall be regarded as payments by way of advance against the final payments only and not as payments for work actual done and completed and shall not preclude the Engineer In-charge from requiring any bad, unsound, imperfect or unskilful work to be removed or taken away and reconstructed or re-erected nor shall any such payment be considered as an admission of the due performance of the contract or any part thereof in any respect or the offering of any claim not shall it conclude, determine or effect in any other way, the powers of the Engineer In-charge as to the final settlement and adjustment of the accounts or otherwise, or in any other way vary or effect the contract. The final bill shall be submitted by the Contractor within one month of the date fixed for the completion of the work otherwise the Engineer In-charge's certificate of the measurements and of the total amount payable for the work shall be final and binding on all parties.

36.4 The payment to the contractor for this work shall be made based on the reports generated in the VTMS (Vehicle Tracking & Management System) System/ WMS & other such IT systems developed by BMC.

37. The Contractor shall not be entitled to compensation to the extent that the Employer's interests are adversely affected by the Contractor for not having given early warning or not having cooperated with the Engineer.

38. Tax

G.S.T. and other state levies/cess which are not subsumed under GST will be applicable. The tenderer shall quote inclusive of all taxes applicable at the time of bid submission. It is clearly understood that BMC will not bear any additional liability towards payment of any Taxes & Duties.

Wherever the Services to be provided by the Tenderers, falls under Reverse Charge Mechanism, the Price quoted shall be exclusive of GST, but inclusive of Taxes / Duties /Cess other than GST, if any.

Rates accepted by BMC shall hold good till completion of work and no additional individual claim shall be admissible on account of fluctuations in market rates; increase in taxes / any other levies / tolls etc. except that payment / recovery for overall market situation shall be made as per price Variation and if there is any subsequent change (after submission of bid) in rate of GST applicable on the work/services to be executed as per tender, i.e. any increase will be reimbursed by BMC whereas any reduction in the rate of GST shall be passed on to BMC as per the provisions of GST act.

“Chapter XXI-Miscellaneous, section 171(1) of GST Act, 2017 governs the ‘Anti Profiteering Measure’ (APM)

As per the provision of this section , ‘ Any reduction in rate of tax on any supply of goods or services or the benefit of input tax credit shall be passed on to the recipient by way of commensurate reduction in prices’

Accordingly, the contractor should pass on the complete benefit accruing to him on account of reduced tax rate or additional input tax credit, to BMC. In this regard bidder has to mandatorily submit “Special Annexure-II” on Rs.500/- stamp paper.

Further, all provisions of GST Act will be applicable to the tender”

39. Currencies

All payments will be made in Indian Rupees.

40. Liquidated Damages

Both, the Contractor and the Employer have agreed that it is not feasible to precisely estimate the amount of losses due to delay in completion of works and the losses to the public and the economy, therefore, both the parties have agreed that the Contractor shall pay liquidated damages to the Employer and not by way of penalty, at the rate per week or part thereof stated in the Contract Data for the period that the Completion Date is later than the Intended Completion Date. Liquidated damages at the same rates shall be withheld if the Contractor fails to achieve the milestones prescribed in the Contract Data. However, in case the Contractor achieves the next milestone, the amount of the liquidated damages already withheld shall be restored to the Contractor by adjustment in the next payment certificate. The Employer and the contractor have agreed that this is a reasonable agreed amount of liquidated damage. The Employer may deduct liquidated damages from payments due to the Contractor. Payment of liquidated damages shall not affect the Contractor's other liabilities.

41. Cost of Repairs

Loss or damage to the Works or Materials to be incorporated in the Works between the Start Date and the end of the Defects Correction periods shall be remedied by the Contractor at his cost if the loss or damage arises from the Contractor's acts or omissions.

E. Finishing the Contract

42. Completion of Work & Maintenance

The Contractor shall request the Engineer to issue a certificate of completion of the works, and the Engineer will do so upon deciding that the works is completed. This shall be governed as per clause no. 8(g) of Standard General Conditions of Contract.

43. Taking Over

43.1 The Employer shall take over the works within seven days of the Engineer issuing a certificate of completion of works. The Contractor shall continue to remain responsible for its routine maintenance during the

maintenance period if specified in the contract.

44. Final Account

Final joint measurement alongwith the representatives of the contractor should be taken recorded and signed by the Contractors. **Contractors should submit the final bill within 1 month of physical completion of the work.**

If the contractor fails to submit the final bill within 1 month, the MCGM staff will prepare the final bill based on the joint measurement within next 3 months.

Engineer's decision shall be final in respect of claims for defect and pending claims against contractors.

No further claims should be made by the Contractor after submission of the final bill and these shall be deemed to have been waived and extinguished. Payment of those items of the bills in respect of which there is no dispute and of items in dispute, for quantities and rates as approved by the Commissioner shall be made within a reasonable period as may be necessary for the purpose of verification etc.

After payment of the final bill as aforesaid has been made, the contractor may, if he so desires, reconsider his position in respect of a disputed portion of the final bills and if he fails to do so within 84 days, his disputed claim shall be dealt with as provided in the contract.

~~A percentage of the retention money, over and above the actual retention money as indicated below shall be held back from payments till the finalization of final bill to be submitted as per above and will be paid within 30 days of acceptance of the final bill.~~

Sr.no.	Amount of Contract Cost	Minimum Payable Amount in final bill
1	Upto Rs.5 Crs.	Rs.10 Laes or final bill whichever is more
2	Upto Rs.25 Crs.	Rs.1 Crore or final bill amount whichever is more
3	Upto Rs. 50 Crs.	Rs.2 Crores or final bill amount whichever is more

4	Upto Rs.100 Crs.	Rs.4 Crore or final bill amount whichever is more
5	More than Rs.100 Crs.:	Rs.7 Crore or final bill amount whichever is more

The contractor have to submit the bill for the work carried out within 15 days from the date of completion of the work to the respective executing department. If the contractor fails to submit their bills to concerned executing department, penalty or action as shown below will be taken for each delayed bill

After 15 days from the date of completion/running bill upto certain date, upto next 15 days i.e. upto 30days	Equal to 5% of bill amount
Next 15 days upto 45 days from the date of completion/running bill upto specified date	Equal to 10% of bill amount
If not submitted witin 45 days from the date of completion/ R.A. bill	Bill will not be admitted for payment.

45. Operating and Maintenance Manuals

If "as built" Drawings and/or operating and maintenance manuals are required, the Contractor shall supply them by the dates stated in the Contract Data.

If the Contractor does not supply the Drawings and/or manuals by the dates stated in the Contract Data, or they do not receive the Engineer's approval, the Engineer shall withhold the amount stated in the Contract Data from payments due to the Contractor.

46. Termination

46.1 The Employer or the Contractor may terminate the Contract if the other party causes a fundamental breach of the Contract.

46.2 Fundamental breaches of Contract shall include, but shall not be limited to, the following:

- a) The Contractor stops work when no stoppage of work is shown on the current Programme and the stoppage has not been authorized by the Engineer;
- b) The Contractor is declared as bankrupt or goes into liquidation other than for approved reconstruction or amalgamation;
- c) the Engineer gives Notice that failure to correct a particular Defect is a fundamental breach of Contract and the Contractor fails to correct it within a reasonable period of time determined by the Engineer;
- d) The Contractor does not maintain a Security, which is required;
- e) The Contractor has delayed the completion of the Works by the number of days for which the maximum amount of liquidated damages can be paid, as defined in relevant clause.
- f) The Contractor fails to provide insurance cover as required under relevant clause.
- g) If the Contractor, in the judgment of the Employer, has engaged in the corrupt or fraudulent practices as defined in GCC in competing for or in executing the Contract.
- h) Any other fundamental breaches as specified in the Contract Data.
- i) If the Contractor fails to deploy machinery and equipment or personnel as specified in the Contract Data at the appropriate time.

46.3 When either party to the contract gives notice of a breach of contract to the Engineer for a cause other than those listed above, the Engineer shall decide whether the breach is fundamental or not.

46.4 Notwithstanding the above, the Employer may terminate the Contract for convenience.

46.5 If the Contract is terminated, the Contractor shall stop work immediately, make the Site safe and secure, and leave the Site as soon as reasonably possible.

47. Payment upon Termination

47.1 If the Contract is terminated because of a fundamental breach of Contract by the Contractor, the Engineer shall issue a certificate for value of

the work done and materials ordered less liquidated damages, if any, less advance payments received up to the date of the issue of the certificate and less the percentage to apply to the value of the work not completed, as indicated in the Contract Data. If the total amount due to the Employer exceeds any payment due to the Contractor, the difference shall be recovered from the security deposit, and performance security. If any amount is still left un-recovered it will be a debt due from the Contractor to the Employer

47.2 If the Contract is terminated at the Employer's convenience, the Engineer shall issue a certificate for the value of the work done, the reasonable cost of removal of Equipment, repatriation of the Contractor's personnel employed solely on the Works, and the Contractor's costs of protecting and securing the Works and less advance payments received up to the date of the certificate, less other recoveries due in terms of the Contract, and less taxes due to be deducted at source as per applicable law.

48. Property

All Materials on the Site, Plant, Equipment, Temporary Works, and Works shall be deemed to be the property of the Employer for use for completing balance construction work if the Contract is terminated because of the Contractor's default, till the Works is completed after which it will be transferred to the Contractor and credit, if any, given for its use.

49. Release from Performance

If the Contract is frustrated by the outbreak of war or by any other event entirely outside the control of the Employer or the Contractor, the Engineer shall certify that the Contract has been frustrated. The Contractor shall make the Site safe and stop work as quickly as possible after receiving this certificate and shall be paid for all work carried out before receiving it and for any work carried out afterwards to which a commitment was made.

F) Other Conditions of Contract

50. Labour

50.1 The Contractor shall, unless otherwise provided in the Contract, make his own arrangements at his own cost for the engagement of all staff and employees, local or other, and for their payment, ~~housing, feeding and transport.~~

50.2 The Contractor shall, if required by the Engineer, deliver to the Engineer a return in detail, in such form and at such intervals as the Engineer may prescribe, showing the staff and the number of the several classes of labour from time to time employed by the Contractor on the Site and such other information as the Engineer may require.

51. Compliance with Labour Regulations

(a) During continuance of the Contract, the Contractor shall abide at all times by all existing labour enactments and rules made there under, regulations, notifications and bye laws of the State or Central Government or local authority and any other labour law (including rules), regulations, bye laws that may be passed or notification that may be issued under any labour law in future either by the State or the Central Government or the local authority.

(b) Furthermore, the Contractor shall keep the Employer indemnified in case any action is taken against the Employer by the competent authority on account of contravention of any of the provisions of any Act or rules made there under, regulations or notifications including amendments. If the Employer is caused to pay or reimburse, such amounts as may be necessary to cause or observe, or for non-observance of the provisions stipulated in the notifications/bye laws/Acts/Rules/regulations including amendments, if any, on the part of the Contractor, the Engineer/Employer shall have the right to deduct any money due to the Contractor including his amount of contract deposit in the form of BG. The Employer/Engineer shall also have right to recover from the Contractor any sum required or estimated to be required for making good the loss or damage suffered by the Employer.

(c) The Contractor shall require his employees to obey all applicable laws, including those concerning safety, health & Environment at work.

(d) The employees of the Contractor or his subcontractor in no case shall be treated as the employees of the BMC at any point of time.

52. Drawings and Photographs of the Works

52.1 The Contractor shall do photography/video photography of the site firstly before the start of the work, secondly mid-way in the execution of different stages of work as required by Engineer In-charge and lastly after the completion of the work. No separate payment will be made to the Contractor for this.

52.2 The Contractor shall not disclose details of Drawings furnished to him and works on which he is engaged without the prior approval of the Engineer in writing. No photograph of the works or any part thereof or plant employed thereon, except those permitted under above clause, shall be taken or permitted by the Contractor to be taken by any of his employees without the prior approval of the Engineer in writing. No photographs/ Video photography shall be published or otherwise circulated without the approval of the Engineer in writing.

53. The Apprentices Act, 1961

The Contractor shall duly comply with the provisions of the Apprentices Act 1961 (III of 1961), the rules made there under and the orders that may be issued from time to time under the said Act and the said Rules and on his failure or neglect to do so, he shall be subject to all liabilities and penalties provided by the said Act and said Rules.

54. Contract Document

The documents forming the contract are to be taken as mutually explanatory of one another. Unless otherwise provided in the contract, the priority of the documents forming the contract shall be as follows

- 1) Contract Agreement (if completed)
- 2) The letter of Acceptance
- 3) The Bid:
- 4) Addendum to Bid; if any
- 5) Tender Document

- 6) The Bill of Quantities:
- 7) The Specification:
- 8) Detailed Engineering Drawings
- 9) Standard General Conditions of Contracts (GCC)
- 10) All correspondence documents between bidder/contractor and BMC.

55. Conflict of Interest

The Applicant shall not have a conflict of interest (the “Conflict of Interest”) that affects the Bidding Process. Any Applicant found to have a Conflict of Interest shall be disqualified. An Applicant shall be deemed to have a Conflict of Interest affecting the Bidding Process, if

1. A constituent of such Applicant is also a constituent of another Applicant;
or
2. Such Applicant has the same legal representative for purposes of this Application as any other Applicant; or
3. Such Applicant, or any Associate thereof has a relationship with another Applicant, or any Associate thereof, directly or through common third party/ parties, that puts either or both of them in a position to have access to each other’s information about, or to influence the Application of either or each other; or
4. The Applicant shall be liable for disqualification if any legal, financial or technical adviser of the Authority in relation to the Project is engaged by the Applicant, its Member or any Associate thereof, as the case may be, in any manner for matters related to or incidental to the Project. For the avoidance of doubt, this disqualification shall not apply where such adviser was engaged by the Applicant, its Member or Associate in the past but its assignment expired or was terminated 6 (six) months prior to the date of issue of this TENDER. Nor will this disqualification apply where such adviser is engaged after a period of 3 (three) years from the date of commercial operation of the Project.

56. Applications and costs thereof

No Applicant shall submit more than one Application for the Project. An applicant applying individually shall not be entitled to submit another

application either individually. The Applicant shall be responsible for all of the costs associated with the preparation of their Applications and their participation in the Bid Process. The Authority will not be responsible or in any way liable for such costs, regardless of the conduct or outcome of the Bidding Process.

57. Acknowledgment by Applicant

It shall be deemed that by submitting the Application, the Applicant has:

- a. made a complete and careful examination of the tender;
- b. received all relevant information requested from the Authority;
- c. accepted the risk of inadequacy, error or mistake in the information provided in the tender or furnished by or on behalf of the Authority relating to any of the matters referred; and
- d. Agreed to be bound by the undertakings provided by it under and in terms hereof.

“The Authority” shall not be liable for any omission, mistake or error in respect of any of the above or on account of any matter or thing arising out of or concerning or relating to the TENDER or the Bidding Process, including any error or mistake therein or in any information or data given by the Authority.

58. Right to reject any or all Applications/ Bids

Notwithstanding anything contained in this TENDER, “The Authority” reserves the right to reject any Application and to annul the Bidding Process and reject all Applications/ Bids, at any time without any liability or any obligation for such acceptance, rejection or annulment, and without assigning any reasons therefore. In the event that the Authority rejects or annuls all the Bids, it may, in its discretion, invite all eligible Bidders to submit fresh Bids hereunder.

“The Authority” reserves the right to reject any Application and/ or Bid if:

- (a) at any time, a material misrepresentation is made or uncovered, or
- (b) the Applicant does not provide, within the time specified by the Authority, the supplemental information sought by the Authority for evaluation of the Application.

In case it is found during the evaluation or at any time before signing of the Agreement or after its execution and during the period of subsistence thereof including the concession thereby granted by “The Authority”, that one or more of the pre-qualification conditions have not been met by the Applicant, or the Applicant has made material misrepresentation or has given any materially incorrect or false information, the Applicant shall be disqualified forthwith if not yet appointed as the Successful Bidder either by issue of the LOA (Letter of Approval) or entering into of the Agreement, and if the Applicant has already been issued the LOA or has entered into the Concession Agreement, as the case may be, the same shall, notwithstanding anything to the contrary contained therein or in this TENDER, be liable to be terminated, by a communication in writing by “The Authority” to the Applicant, without the Authority being liable in any manner whatsoever to the Applicant and without prejudice to any other right or remedy which the Authority may have under this TENDER, the Bidding Documents, the Concession Agreement or under applicable law.

“The Authority” reserves the right to verify all statements, information and documents submitted by the Applicant in response to the TENDER. Any such verification or lack of such verification by the Authority shall not relieve the Applicant of its obligations or liabilities hereunder nor will it affect any rights of the Authority there under.

59. The bid shall be rejected if the bidder-

- a. Stipulates the validity period less than 180 days.
- b. Stipulates own condition/conditions.
- c. Does not fill and (digital) sign undertaking forms, which are incorporated, in the document.

60. Clarifications

Applicants requiring any clarification on the tender may notify “the Authority” in writing or ~~by fax~~ or e-mail. They should send in their queries before the date specified in the header data. “The Authority” shall Endeavor to respond to the queries within the period specified therein. The responses will be sent by ~~fax~~ and/or e-mail if necessary. The Authority will forward all the queries and its responses thereto, to all purchasers of the TENDER without identifying the source of queries.

“The Authority” shall Endeavor to respond to the questions raised or clarifications sought by the Applicants. However, the Authority reserves the right not to respond to any question or provide any clarification, in its sole discretion, and nothing in this Clause shall be taken or read as compelling or requiring the Authority to respond to any question or to provide any clarification, but not later than the date provided in header data.

“The Authority” may also on its own motion, if deemed necessary, issue interpretations and clarifications to all Applicants. All clarifications and interpretations issued by the Authority shall be deemed to be part of the tender. Verbal clarifications and information given by Authority or its employees or representatives shall not in any way or manner be binding on the Authority.

61. Amendment of tender

At any time prior to the deadline for submission of Application, the Authority may, for any reason, whether at its own initiative or in response to clarifications requested by an Applicant, modify the tender by the issuance of Addendum.

Any Addendum thus issued will be sent in writing/~~Fax~~/ Email/ to all those who have purchased the tender or published on BMC portal.

In order to afford the Applicants a reasonable time for taking an Addendum into account, or for any other reason, the Authority may, in its sole discretion, extend the Application Due Date.

G) Preparation and Submission of Application

62. Language

The Application and all related correspondence and documents in relation to the Bidding Process shall be in English language. Supporting documents and printed literature furnished by the Applicant with the Application may be in any other language provided that they are accompanied by translations of all the pertinent passages in the English language, duly authenticated and certified by the Applicant. Supporting materials, which are not translated into English, may not be considered. For the purpose of interpretation and evaluation of the Application, the English language translation shall prevail.

63. Format and signing of Application

The Applicant shall provide all the information sought under this TENDER. The Authority will evaluate only those Applications that are received in the required formats and complete in all respects. Incomplete and /or conditional Applications shall be liable to rejection.

The Applicant will upload bid in One Folder in electronic form which shall contain the scanned certified copies of the documents given below and the documents uploaded has to be digitally signed by the bidder. These copies shall be certified by Practicing Notary approved by the Govt. of Maharashtra or Govt. of India with his stamp, clearly stating his name & registration number, except where original documents are demanded.

64. Marking of Applications

The Applicant shall submit the Application in the format specified, together with the documents, upload in folder as “VENDOR” together with their respective enclosures

Applications submitted by fax, telex, telegram shall not be entertained and shall be rejected outright.

65. Late Applications

Applications received by the Authority after the specified time on the Application Due Date shall not be eligible for consideration and shall be summarily rejected.

66. Confidentiality

Information relating to the examination, clarification, evaluation, and recommendation for the short-listed qualified Applicants shall not be disclosed to any person who is not officially concerned with the process or is not a retained professional advisor advising the Authority in relation to or matters arising out of, or concerning the Bidding Process. The Authority will treat all information, submitted as part of Application, in confidence and will require all those who have access to such material to treat the same in confidence. The Authority may not divulge any such information unless it is directed to do so by any statutory entity that has the power under law to require its disclosure or is to enforce or assert any right or privilege of the

statutory entity and/ or the Authority or as may be required by law or in connection with any legal process.

67. Clarification of Financial Bids

To assist in the examination, evaluation and comparison of Bids, the Engineer may, at his discretion, ask any bidder for clarification of his Bid, including breakdown of unit rates. The request for clarification and the response shall be in writing or by post/~~faesimile~~/e-mail. No Bidder shall contact the Engineer on any matter relating to his bid from the time of the bid opening to the time the contract is awarded. Any effort by the Bidder to influence the Engineer in the Engineer's bid evaluation, bid comparison or contract award decisions may result in the rejection of the Bidder's bid.

68. Inspection of site and sufficiency of tender:

1. The Contractor shall inspect and examine the site and its surrounding and shall satisfy himself before submitting his tender as to the nature of the work (so far as is practicable), the form and nature of the site, the quantities and nature of the work and materials/equipment/vehicles necessary for the completion of the works and means of access to the site, and in general shall himself obtain all necessary information as to risk, contingencies and other circumstances which may influence or affect his tender. He shall also take into consideration the hydrological and climatic conditions.

2. The employer may make available to the Contractor data on hydrological and subsurface conditions as obtained by or on his behalf from investigations relevant to the works but the Contractor shall be responsible for his own interpretation thereof. The contractor shall engage his investigating agency with prior approval of the Engineer from the approved list of such agencies by MCGM or Govt at his cost initially before commencing actual work and which shall be reimbursed immediately subject to satisfaction of the Engineer for faithful compliance and submission of required data regarding such investigation within specified time.

3. The Contractor shall be deemed to have satisfied himself before tendering as to the correctness and sufficiency of his tender for the works and of the rates and prices quoted in the schedule of works / items / quantities, or in Bill of Quantities, which rates and prices shall, except as otherwise provided

cover all his obligations under the Contract and all matters and things necessary for proper completion and maintenance of the works. No extra charges consequent on any misunderstanding.

4. Not Foreseeable Physical Obstructions or Conditions: If, however, during the execution of the Works the Contractor encounters physical obstructions or physical conditions, other than climatic conditions on the Site, which obstructions or conditions were, in his opinion, not foreseeable by an experienced contractor, the Contractor shall forthwith give notice thereof to the Engineer. On receipt of such notice, the Engineer shall, if in his opinion such obstructions or conditions could not have been reasonably foreseen by an experienced contractor, after due consultation with the Contractor, determine:

- any extension of time to which the Contractor is entitled and
- and shall notify the Contractor accordingly. Such determination shall take account of any instruction which the Engineer may issue to the Contractor in connection therewith, and any proper and reasonable measures acceptable to the Engineer which the Contractor may take in the absence of specific instructions from the Engineer. However, such costing shall be got approved by the competent authority as governed vide rules prevailing with authority.

5. Office for the Engineer (Works costing upto Rs.50 Lakhs)

~~The Contractor shall at his own cost and to satisfaction of the Engineer provide a small temporary office, at the work site which will include tables, chairs and lockers for keeping the records. He shall also make necessary arrangements for drinking water, telephone with a pre-requisite of e-governance and electronic communication. These offices are not to be allowed on public roads without the written instruction of the Engineer. These offices should be preferably located within 50 to 500 m of the worksite. In case the office is more than 500m away from the worksite, the contractor is to provide conveyance for Municipal Staff.~~

6. Office for the Engineer (Works costing above Rs.50 lakhs)

The Contractor shall at his own cost and to satisfaction of the Engineer provide a temporary office at the work-site which will include tables, chairs and lockers for keeping the records. He shall also make necessary arrangements for drinking water, latrines, with doors, windows, locks, bolts and fastenings sufficient for security for the Engineer, and his subordinates, as close to the works from time to time in progress as can be conveniently arranged, and shall at his own cost furnish the office with such chairs, tables, lockers, locks and fastenings as may be required by the Engineer, and no expense of any kind in connection with the erection or upkeep of the offices or fittings shall be borne by the Corporation, but all such work shall be carried out by the Contractor and the expenses thereof defrayed by him. The Contractor shall also make water connections and fit up stand pipe with a bib tap at each office. The latrines and the water connections shall be subject to all the conditions herein elsewhere laid down for temporary water connection and latrines generally with all requisite equipments for e-governance and electronic and digital communication. These offices are not to be allowed on public roads without the written instruction of the Engineer. These offices should be preferably located within 50 to 500 m of the worksite. In case the office is more than 500m away from the worksite, the contractor is to provide conveyance. Also, for staff working beyond working hours the contractor has to provide conveyance

7. Permission for provision and removal of office on completion of work:

The tenderer shall obtain permission for provision of site office, cement go-down, store, etc. on payment of necessary cost implication. The cement go-down, Watchman cabins, etc. shall Supply, Installation, Testing and commissioning of Split type AC units of various capacity at Bhandup Complex. Page 85 be provided as directed and shall be removed by the Tenderers on completion of the work at their cost. It is binding on the Tenderer to fulfill requirements of Environmental Authorities. The location of such office shall be finalized and got approved from the Engineer before erection / commencement work.

69. Official Secrecy:

The Contractor shall of all the persons employed in any works in connection with the contract that the India Official Secrets Act 1923 (XIX of 1923) applies to them and will continue to apply even after execution of the said works and they will not disclose any information regarding this contract to any third party. The contractor shall also bring into notice that, any information found to be leaked out or disclosed the concern person as well as the Contractor will be liable for penal action; further the Corporation will be at liberty to terminate the contract without notice.

70. Subsequent Legislation:

If on the day of submission of bids for the contract, there occur changes to any National or State statute, Ordinance, decree or other law or any regulation or By-laws or any local or other duly constituted authority or the introduction of any such National or State Statute, Ordinance, decree or by which causes additional or reduced cost to the Contractor, such additional or reduced cost shall, after due consultation with the Contractor, be determined by the concerned Engineering Department of BMC and shall be added to or deducted from the Contract Price with prior approval of competent authority and the concerned Engineering Department shall notify the Contractor accordingly with a copy to the Employer. BMC reserve the right to take decision in respect of addition/reduction of cost in contract.

71. Patent, Right and Royalties:

The contractor shall save harmless and indemnify the Corporation from and against all claims and proceedings for or on account of infringement of any Patent rights, design trademark or name of other protected rights in respect of machine work, or material used for or in connection with the Works or any of them and from and against all claims, proceedings, damages, costs, charges and expenses whatsoever in respect thereof or in relation thereto. Except where otherwise specified, the contractor shall pay all tonnage and other royalties, rent and other payments or compensation, if any, for getting stone, sand, gravel, clay or other materials required for the works or any of them.

72. Payments, Tax and Claims:

- The limit for unforeseen claims**

Under no circumstances whatever the contractor shall be entitled to any compensation from BMC on any account unless the contractor shall have submitted a claim in writing to the Eng. in charge within 1 month of the case of such claim occurring.

□ No interest for delayed payments due to disputes, etc:

It is agreed that the Brihanmumbai Municipal Corporation or its Engineer or Officer shall not be liable to pay any interest or damage with respect of any moneys or balance which may be in its or its Engineer's or officer's hands owing to any dispute or difference or claim or misunderstanding between the Municipal Corporation of Greater Bombay or its Engineer or Officer on the one hand and the contractor on the other, or with respect to any delay on the part of the Brihanmumbai Municipal Corporation or its Engineer or Officers in making periodical or final payments or in any other respect whatever.

73. Settlement of Disputes:

□ Termination of contract for death

If the Contractor is an individual or a proprietary concern and the individual or the proprietor dies and if the Contractor is a partnership concern and one of the legal representative of the individual Contractor or the proprietor of the proprietary concern and in case of partnership, the surviving partners, are capable of carrying out and completing the contract, the Commissioner shall be entitled to cancel the contract as to its uncompleted part without the Corporation being in any way liable to payment of any compensation to the estate of the deceased Contractor and or to the surviving partners of the Contractor's firm on account of the cancellation of the contract. The decision of the Commissioner that the legal representative of the deceased Contractor or surviving partners of the Contractor's firm cannot carry out and complete the contract shall be final and binding on the parties. In the event of such cancellation the Commissioner shall not hold estate of the deceased Contractor and or surviving partners of the Contractor's firm liable in damages for not completing the contract.

□□ Settlement of Disputes:

If any dispute or differences of any kind whatsoever other than those in respect of which, the decision of any person is, by the Contract, expressed to

be final and binding) shall arise between the Employer and the Contractor or the Engineer and the Contractor in connection with or arising out of the Contract or carrying out of the Works (Whether during the progress of the Works or after their completion and whether before or after the termination, abandonment or breach of the Contract) it, the aggrieved party may refer such dispute within a period of 7 days to the concerned Addl. Municipal Commissioner who shall constitute a committee comprising of three officers i.e. concerned Deputy Municipal Commissioner or Director (ES&P), Chief Engineer other than the Engineer of the Contract and concerned Chief Accountant. The Committee shall give decision in writing within 60 days. Appeal on the Order of the Committee may be referred to the Municipal Commissioner within 7 days. Thereafter the Municipal Commissioner shall constitute a Committee comprising of three Addl. Municipal Commissioners including Addl. Municipal Commissioner in charge of Finance Department. The Municipal Commissioner within a period of 90 days after being requested to do so shall give written notice of committee's decision to the Contractor. Save as herein provided such decision in respect of every matter so referred shall be final and binding upon both parties until and after the completion of the works, and shall forthwith be given effect to by the Contractor who shall proceed with the works with due diligence, whether he requires arbitration as hereinafter provided or not. If the Commissioner has given written notice of the decision to the Contractor and no Claim to arbitration has been communicated within a period of 90 days from receipt of such notice the said decision shall remain final and binding upon the Contractor.

74. Arbitration and Jurisdiction:

If the Commissioner shall fail to give notice of the decision as aforesaid within a period of 90 days after being requested as aforesaid, or if the Contractor be dissatisfied with any such decision, then and in any such case the Contractor may within 90 days after receiving notice of such decision or within 90 days after the expirations of the first named period of 90 days (as the case may be) require that the matter or matters in dispute be referred to arbitration as hereinafter provided.

i) In case of the contract where the contract price and/or contract value is less than Rs. 5,00,00,000/- (Rupees Five Crore Only), any dispute arising out of or in

connection with this contract, including any question regarding its existence, validity or termination, shall be referred to a mutually agreed arbitral tribunal in accordance with the Arbitration and Conciliation Act, 1996 (amended upto date). The arbitral tribunal shall consist of sole arbitrator, as mutually agreed upon by the parties and the said dispute shall be finally resolved by said arbitral tribunal. The decision of the arbitral tribunal shall be given in writing (with reasons) and which will be final & binding upon the parties hereto & the expenses of the arbitration shall be paid as may be determined by the arbitral tribunal. The seat of the arbitration shall be Mumbai. The venue of arbitration shall be English.

If the parties fails to appoint mutually agreed arbitral tribunal, within the period of 30 days from the date of application seeking arbitration in the dispute, the arbitral tribunal shall be appointed by recognized arbitral institution i.e. Mumbai Centre for International Arbitration (approved by Government of Maharashtra under G.R. no. ARB/case No. 1,/2017/D-19 dtd. 28.02.2017) as per Arbitration Rules of Mumbai Centre for International Arbitration then in force (“MCIA Rules”)

(ii) In case of contract where the contract price and/or contract value is Rs. 5,00,00,000/- (Rupees Five Crore Only) or more, any dispute arising out of or in connection with such a contract, including any question regarding its existence, validity or termination, shall be directly referred to and finally resolved by recognized arbitral institution i.e. Mumbai Centre for International Arbitration (approved by Government of Maharashtra under G.R. no. ARB/case No. 1,/2017/D-19 dtd. 28.02.2017) as per Arbitration Rules of Mumbai Centre for International Arbitration then in force (“MCIA Rules”). The arbitral tribunal shall consist of a sole arbitrator. The seat of the arbitration shall be Mumbai. The language of the Arbitration shall be English. In either case, the law governing this arbitration agreement and the contract shall be in Indian Law.

75. Copyright: The copyright of all drawings and other documents provided by the Contractor under the contract shall remain vested in the Contractor or his sub-contractors as the case may be the employer shall have a license to use such drawings and other documents in connection with the design, construction, operation, maintenance of the works. At any time the Employer shall have further license without additional payment to the Contractor to use any such drawings or documents for the purpose of making any improvement of the works or enlargement or duplication of any part thereof, provided that such improvement, enlargement, or duplication by itself or in conjunction with any other improvements, enlargements or duplications already made in accordance with the further license does not result in the duplication of the whole works.

76. Receipts to be signed in firm's name by any one of the partners:

Every receipt for money which may become payable or for any security which may become transferable to the Contractor under these present shall, if signed in the partnership name by any one of the partners, be a good and sufficient discharge to the Commissioner and Municipal Corporation in respect of the money or security purporting to be acknowledged thereby, and in the event of death of any of the partners during the pendency of this contract, it is hereby expressly agreed that every receipt by any one of the surviving partners shall, if so signed as aforesaid, be good and sufficient discharge as aforesaid provided that nothing in this clause contained shall be deemed to prejudice or effect any claim which the Commissioner or the Corporation may hereafter have against the legal representatives of any partners so dying or in respect of any breach of any of the conditions thereof, provided also that nothing in this clause contained shall be deemed prejudicial or affect the respective rights or obligations of the Contractors and of the legal representatives of any deceased Contractors interest.

77. Proprietary data

All documents and other information supplied by the Authority or submitted by an Applicant to the Authority shall remain or become the property of the Authority. Applicants are to treat all information as strictly confidential and shall not use it for any purpose other than for preparation and submission of their Application. The Authority will not return any Application or any information provided along therewith.

78. Correspondence with the Applicant

Save and except as provided in this TENDER, the Authority shall not entertain any correspondence with any Applicant in relation to the acceptance or rejection of any Application.

79. Price Variation Clause

~~The Contractor shall be reimbursed or shall refund to the Corporation as the case may be the variation in the value of the work carried out from time to time,~~

~~depending on whether the prices of material and labour as a whole rise or fall, and the method adopted for such computations shall be as given below, it being clearly understood that the contractor shall have no claim for being reimbursed on the ground that the price of a particular material or group of materials have risen beyond the limits of the presumptions made in the following paras, however, no price variations shall be made applicable for contracts upto 12 months:~~

~~A) Controlled materials: Price variations shall be permitted in respect of these materials the price level of which is controlled by the Government or its agency. The rate ruling on the date of submission of the tender shall be considered as the basic price of such material for adjustment. Any variation in this rate shall be considered for reimbursement to the contractor or refund to be claimed from the contractor as the case may be. The contractor shall, for the purpose of adjustment submit in original the relevant documents from the suppliers.~~

~~B) Labour and other materials: For the purpose of this contract and for allowing reimbursement or refund on account of variation of prices of (i) labour, and (ii) materials other than materials mentioned in A above, computation will be based on the formula enunciated below which is based on the presumptions that:~~

~~i) The general price level of labour, rises or falls in proportion to the rise or fall of consumer price index number 9 (general) for working class in Mumbai.~~

~~ii) The general price level of materials rises or falls in proportion to rise or fall of whole sale price index as published by 'Economic Adviser to Govt. of India'~~

~~i) And that the component of labour is to the extent of 30 percent of 88 percent and the component of materials is to the extent of 70 percent of 88 percent of the value of the work carried out. The remaining 12 percent being the presumptive profit of the contractor.~~

~~a) Formula for Labour component:~~

$$\text{VL} = (0.88 R) \times 30 \times (I - IO) / 100 - IO$$

~~b) Formula for Material component :~~

$$\text{VM} = (0.88 R \times 70 - C) \times (W - WO) / 100 - WO$$

~~Where -~~

~~VL = Amount of price variation to be reimbursed or claimed as refund on account of general rise or fall of index referred to above.~~

~~I = Consumer Price Index number of working class for Mumbai (declared by the Commissioner of Labour and Director of Employment, Mumbai) applicable to the period under reference (base year ending 2004-05 as 100 i.e. new series of indices).~~

~~IO = Consumer price index number for working class for Mumbai (declared by the Commissioner of labour and Director of Employment, Mumbai) prevailing, on the day of 28 days prior to the date of submission of the tender.~~

~~VM = The amount of price variation to be reimbursed or claimed as refund on account of general rise or fall of wholesale price index for period under reference.~~

~~W = Average wholesale price index as published by Economic Adviser to Govt. of India applicable to the period under reference.~~

~~WO = Wholesale price index as stated above prevailing on the day of 28 days prior to the date of submission of the tender.~~

~~R = Total value of the work done during the period under reference as recorded in the Measurement Book excluding water charges and sewerage charges but including cost of excess in respect of item upto 50 percent~~

~~C = Total value of Controlled materials used for the works as recorded in Measurement Book and paid for at original basic rate plus the value materials of used.~~

~~i) The quantity of the Controlled material adopted in working out the value of 'C' shall be inclusive of permitted wastages as / if mentioned in specifications.~~

~~ii) The basic rate for the supply of controlled material shall be inclusive of all the components of cost of materials excluding transport charges incurred for bringing the material from place of delivery to the site.~~

~~Computations based on the above formula will be made for the period of each bill separately and reimbursement will be made to (when the result is plus) and refund will be claimed from (when the result is minus) the contractor's next bill. The above formulae will be replaced by the formulae in Annexure-I as and when mentioned in special conditions of contract~~

~~The operative period of the contract for application of price variation shall mean the period commencing from the date of commencement of work mentioned in the work order and ending on the date when time allowed for the work order and ending on the date when time allowed for the work specified in the contract for work expires, taking into consideration, the extension of time, if any, for completion of the work granted by Engineer under the relevant clause of the conditions of contract in cases other than those where such extension is necessitated on account of default of the contractor.~~

~~The decision of the Engineer as regards the operative period of the contract shall be final and binding on the contractors.~~

~~iii) Where there is no supply of controlled items to contractor the component 'C' shall be taken as zero.~~

~~B) Adjustment after completion: If the Contractor fails to complete the works within the time for completion adjustment of prices thereafter until the date of completion of the works shall be made using either the indices or prices relating to the prescribed time for completion, or the current indices or prices whichever is more favorable to the employer, provided that if an extension of time is granted, the above provision shall apply only to adjustments made after the expiry of such extension of time.~~

~~C) Price variation will be calculated similarly and separately for extra items and / or excess quantities and provisional sums calculated under Sub Clause 10 (b)A (i)&(ii) and Sub Clause 10 (b) B(ii) based on the above formula/formulae in Annexure-I as and when mentioned in Special conditions of contract; IO and WO being~~

~~the indices applicable to the date on which the rates under Sub Clause 10 (a)A (i)&(ii) and Sub Clause 10 (a) B(iii) are fixed. No price variation shall be admissible for FAIR items created during execution.~~

~~D) Price variation will be calculated similarly and separately for extra items and / or excess quantities and provisional sums calculated under Sub Clause 10 (b)A (i)&(ii) and Sub Clause 10 (b) B(ii) based on the above formula/formulae in Annexure I as and when mentioned in Special conditions of contract; IO and WO being the indices applicable to the date on which the rates under Sub Clause 10 (a)A (i)&(ii) and Sub Clause 10 (a) B(iii) are fixed. No price variation shall be admissible for FAIR items created during execution.~~

80. Maximum Price Variation shall be as follows:

Time Period of Project	Maximum limit of Price Variation
Up to 12 months	No variation allowed
Above 12 months to 24 months	5%
Above 24 months	10%

*Approval of AMC / MC shall be obtained before invitation of tender in case of any changes in above

Note: 1) The extension in time period for the projects originally estimated including monsoon results in change of price variation slabs as mentioned above i.e. from first slab to

second slab or from second slab to third slab, then the maximum limit of original slab will prevail.

2) Operative period shall mean original or extended time period of contract.)
Operative period shall mean original or extended time period of contract.

For example:

Extension of Time period	Maximum Price Variation
If original period of 11 months including monsoon extends to 16. The	No variation allowed

operative period will be 11+5 months.	
If original period of 11 months excluding monsoon extends to 16.The operative period will be 11+5 months.	Maximum 5% variation allowed

Price Variation during Extended Period of Contract:

i) Extension Due To Modification & Extension for delay due to MCGM : The price variation for the period of extension granted shall be limited to the amount payable as per the Indices. In case the indices increases or decreases, above/below the indices applicable, to the last month of the original or extended period vide clause 8(l)(a)(i) and (ii) of standard GCC

ii) Extension Of Time For Delay Due To Contractor :

a) The price variation for the period of extension granted shall be limited to the amount payable as per the Indices in case the indices increase, above the indices applicable, to the last month of the original completion period or the extended period vide above clause 8(l) (a)(i) and (ii) of standard GCC. b) The price variation shall be limited to the amount payable as per the indices, in case the indices decrease or fall below the indices applicable, to the last month of original / extended period of completion period vide above clause 8(l)

(b) of standard GCC, then lower indices shall be adopted.

iii) Extension of Time For Delay due to reasons not attributable to MCGM and Contractor (Reference Cl.8(d) of Standard GCC): The price variation for the period of extension granted shall be limited to the amount payable as per the Indices in case the indices increases or decreases, above/below the indices applicable, to the last month of the original period.

81. Payment:

i) Bills shall be submitted by the Contractor from time to time (but at an interval of not less than one month) for the works executed. The Engineer

shall arrange to have the bills verified by taking or causing to be taken, where necessary, the requisite measurement of work.

ii) Payment on account for amount admissible shall be made on the Engineer certifying the sum to which the Contractor is considered entitled by way of payment for all the work executed, after deducting there from the amount already paid, security deposit/ retention money and such other amounts as may be deductible or recoverable in terms of the contract. Please refer the specification of the tender.

~~iii) On request, the contractor will be paid upto 75 percent of the value of the work carried out as an adhoc payment in the first week of next month after deducting there from recoveries on account of advances, interest, retention money, income tax etc. The balance payment due will be paid thereafter.~~

~~iv) No interim payment will be admitted until such time the Contractor have fully complied with the requirement of the Condition no.8 (g) and 8 (h) concerning submission and approval of Network Schedule for the works, as detailed in Condition 8 (h). A fixed sum shall be held in abeyance at the time of next interim payment for non attainment of each milestone in the network and shall be released only on attainment of the said milestone.~~

~~v) An interim certificate given relating to work done or material delivered may be modified or corrected by a subsequent interim certificate or by the final certificate. No certificate of the Engineer supporting an interim payment shall of itself be conclusive evidence that any work or materials to which it relates is / are in accordance with the contract.~~

82. Banning/De-Registration of Agencies of Construction works/ M & E work in BMC

The regulations regarding Demotion/ Suspension Banning for specific period or permanently / De-Registration shall be governed as per the respective condition in Contractor Registration Rules of BMC.

83. JOINT VENTURE (Not Applicable)

~~In case if Joint Venture is allowed for the Project, the guidelines for JV as follows shall be incorporated in the Tender Document:~~

~~a) Joint Venture should be allowed only when the number of identifiable different works is more than one and/or the estimated cost of tender is more than Rs.100 Crores. JV shall also be allowed for complex technical work below Rs.100 Crores with the approval of concerned AMC~~

~~b) Separate identity/name shall be given to the Joint Venture firm.~~

~~c) Number of members in a JV firm shall not be more than three in normal circumstances, if the work involves only one discipline (say Civil or Electrical). If number of members in JV is required to be more than three, then approval of concerned AMC needs to be sought.~~

~~d) A member of JV firm shall not be permitted to participate either in individual capacity or as a member of another JV firm in the same tender.~~

~~e) The tender form shall be purchased and submitted in the name of the JV firm or any constituent member of the JV.~~

~~f) Normally EMD shall be submitted only in the name of the JV and not in the name of constituent member. However, EMD in the name of lead partner can be accepted subject to submission of specific request letter from lead partner stating the reasons for not submitting the EMD in the name of JV and giving written confirmation from the JV partners to the effect that the EMD submitted by the lead partner may be deemed as EMD submitted by JV firm.~~

~~g) One of the members of the JV firm shall be the lead member of the JV firm who shall have a majority (at least 51%) share of interest in the JV firm. The other members shall have a share of not less than 20% each in case of JV firms with up to three members and not less than 10% each in case of JV firms with more than three members. In case of JV firm with foreign member(s), the lead member has to be an Indian firm with a minimum share of 51%.~~

~~h) A copy of Letter of Intent or Memorandum of Understanding (MoU) executed by the JV members shall be submitted by the JV firm along with the tender. The complete details of the members of the JV firm, their share and responsibility in the JV firm etc. particularly with reference to financial technical and other obligation shall be furnished in the agreement.~~

~~i) Once the tender is submitted, the agreement shall not be modified/alterd/terminated during the validity of the tender. In case the tenderer fails to observe/comply with this stipulation, the full Earnest Money Deposit (EMD) shall be forfeited. In case of successful tenderer, the validity of this agreement shall be extended till the currency of the contract expires.~~

~~j) Approval for change of constitution of JV firm shall be at the sole discretion of the MCGM. The constitution of the JV firm shall not be allowed to be modified after submission of the tender bid by the JV firm except when modification becomes inevitable due to succession laws etc. and in any case the minimum eligibility criteria should not get vitiated. In any case the Lead Member should continue to be the Lead Member of the JV firm. Failure to observe this requirement would render the offer invalid.~~

~~k) Similarly, after the contract is awarded, the constitution of JV firm shall not be allowed to be altered during the currency of contract except when modification become inevitable due to succession laws etc. and in any case the minimum eligibility criteria should not get vitiated. Failure to observe this stipulation shall be deemed to be breach of contract with all consequential penal action as per contract condition.~~

~~l) On award of contract to a JV firm, a single Performance Guarantee shall be required to be submitted by the JV firm as per tender conditions. All the Guarantees like Performance Guarantee, Bank Guarantee for Mobilization advance, machinery Advance etc. shall be accepted only in the name of the JV firm and no splitting of guarantees amongst the members of the JV firm shall be permitted.~~

~~m) On issue of LOA, an agreement among the members of the JV firm (to whom the work has been awarded) has to be executed and got registered before the Registrar of the Companies under Companies Act or before the Registrar / Sub-Registrar under the Registration Act, 1908. This agreement shall be submitted by the JV firm to the MCGM before signing the contract agreement for the work. (This agreement format should invariably be part of the tender condition). In case the tenderer fails to observe/comply with this stipulation, the full Earnest Money Deposit (EMD) shall be forfeited and other penal actions due shall be taken against partners of the JV and the JV. This joint venture agreement shall have, inter-alia, following clauses:-~~

~~**i. Joint and several liability** The members of the JV firm to which the contract is awarded, shall be jointly and severally liable to the Employer (MCGM) for execution of the project in accordance with General and Special conditions of the contract. The JV members shall also be liable jointly and severally for the loss, damages caused to the MCGM during the course of execution of the contract or due to no execution of the contract or part thereof.~~

~~**ii. Duration of the Joint Venture Agreement** It shall be valid during the entire period of the contract including the period of extension if any and the maintenance period after the work is completed.~~

~~**iii. Governing Laws**—The Joint Venture Agreement shall in all respect be governed by and interpreted in accordance with Indian Laws.~~

~~**iv. Authorized Member**—Joint Venture members shall authorize one of the members on behalf of the Joint Venture firm to deal with the tender, sign the agreement or enter into contract in respect of the said tender, to receive payment, to witness joint measurement of work done, to sign measurement books and similar such action in respect of the said tender/contract. All notices/correspondences with respect to the contract would be sent only to this authorized member of the JV firm.~~

~~No member of the Joint Venture firm shall have the right to assign or transfer the interest right or liability in the contract without the written consent of the other members and that of the employer in respect of the said tender / contract.~~

~~**n) Documents to be enclosed by the JV firm along with the tender:**~~

~~**i.** In case one or more of the members of the JV firm is/are partnership firm(s), following documents shall be submitted:~~

~~**a.** Notary certified copy of the Partnership Deed,~~

~~**b.** Consent of all the partners to enter into the Joint Venture Agreement on a stamp paper of appropriate value (in original).~~

~~**c.** Power of Attorney (duly registered as per prevailing law) in favor of one of the partners to sign the MOU and JV Agreement on behalf of the partners and create liability against the firm.~~

~~**ii.** In case one or more members is/are Proprietary Firm or HUF, the following documents shall be enclosed:~~

~~**a.** Affidavit on Stamp Paper of appropriate value declaring that his Concern is a Proprietary Concern and he is sole proprietor of the Concern OR he is in position of "KARTA" of Hindu Undivided Family and he has the authority, power and consent given by other partners to act on behalf of HUF.~~

~~**iii.** In case one or more members is/are limited companies, the following documents shall be submitted:~~

~~**a.** Notary certified copy of resolutions of the Directors of the Company, permitting the company to enter into a JV agreement, authorizing MD or one of the Directors or Managers of the Company to sign MOU, JV Agreement, such other documents required to be signed on behalf of the Company and enter into liability against the company and/or do any other act on behalf of the company.~~

~~**b.** Copy of Memorandum and articles of Association of the Company.~~

~~e. Power of Attorney (duly registered as per prevailing law) by the Company authorizing the person to do/act mentioned in the para (a) above.~~

~~o) All the members of the JV shall certify that they have not been black listed or debarred by MCGM from participation in tenders/contract in the past either in their individual capacity or the JV firm or partnership firm in which they were members / partners.~~

~~p) Credentials & Qualifying criteria: Technical and financial eligibility of the JV firm shall be adjudged based on satisfactory fulfilment of the following criteria:~~

~~**Technical eligibility criteria:** In case of Work involving single discipline, the Lead member of the JV firm shall meet at least 35% requirement of technical capacity as stipulated in tender document.~~

OR

~~In case of composite works (e.g. works involving more than one distinct component such as Civil Engineering works, M & E works, Electrical works, etc. and in the case of major bridges, substructure and superstructure etc.), atleast one member should have satisfactorily completed 35% of the value of any one component of the project work so as to cover all the components of project work or any member having satisfactorily completed 35% of the value of work of each component during last seven financial years.~~

~~**In such cases, what constitutes a component in a composite work shall be clearly defined as part of the tender condition without any ambiguity.**~~

~~**Financial eligibility criteria:** The contractual payments received by the JV firm or the arithmetic sum of contractual payments received by all the members of JV firm in any one of the previous three financial years and shall be at least 100% of the estimated value of the work as mentioned in the tender.~~

84. Compensation for delay:

~~If the Contractor fails to complete the works and clear the site on or before the Contract or extended date(s) / period(s) of completion, he shall, without prejudice to any other right or remedy of Municipal Corporation on account of such breach, pay as agreed compensation, amount calculated as stipulated below (or such smaller amount as may be fixed by the Engineer) on the contract value of the whole work or on the contract value of the time or group of items of work for which separate period of completion are given in the contract and of which completion is delayed for every week that the whole of the work of item or group of items of work concerned remains~~

~~uncompleted, even though the contract as a whole be completed by the contract or the extended date of completion. For this purpose the term 'Contract Value' shall be the value of the work at Contract Rates as ordered including the value of all deviations ordered:~~

- ~~• Completion period for projects (originally stipulated or as extended) not exceeding 6 months : to the extent of maximum 1 percent per week~~
- ~~• Completion period for projects (originally stipulated or as extended) exceeding 6 months and not exceeding 2 years: to the extent of maximum ½ percent per week.~~
- ~~• Completion period for projects (originally stipulated or as extended) exceeding 2 years : to the extent of maximum ¼ percent per week.~~

~~When the delay is not a full week or in multiple of a week but involves a fraction of a week the compensation payable for that fraction shall be proportional to the number of days involved.~~

~~Provided always that the total amount of compensation for delay to be paid this condition shall not exceed the undernoted percentage of the Contract Value of the item or group of items of work for which a separate period of completion is given.~~

- ~~i) Completion period (as originally stipulated or as extended) not exceeding 6 months: 10 percent.~~
- ~~ii) Completion period (as originally stipulated or as extended) exceeding 6 months and not exceeding 2 years : 7½ percent.~~
- ~~iii) Completion period (as originally stipulated or as extended) exceeding 2 years : 5 percent.~~

~~The amount of compensation may be adjusted set off against any sum payable to the contractor under this or any other contract with the Municipal Corporation.~~

~~Please note schedule of penalties in section 10 SPECIFICATION.~~

85. Action and Compensation Payable in Case of Bad Work and Not Done As Per Specifications

All works under or in course of execution or executed in pursuance of the contract, shall at all times be open and accessible to the inspection and supervision of the Engineer-in-charge, his authorized subordinates in charge of the work and all the superior officers, officer of the Vigilance Department of the BMC or any organization engaged by the BMC for Quality Assurance and the contractor shall, at all times, during the usual working hours and at all other times at which reasonable notice of the visit of such officers has been given to the contractor, either himself be present to receive orders and instructions or have a responsible agent duly accredited in writing, present for that purpose. Orders given to the Contractor's agent shall be considered to have the same force as if they had been given to the contractor himself.

If it shall appear to the Engineer-in-charge or his authorized subordinates in-charge of the work or to the officer of Vigilance Department, that any work has been executed with unsound, imperfect or unskillful workmanship or with materials of any inferior description, or that any materials or articles provided by him for the execution of the work are unsound or of a quality inferior to that contracted for or otherwise not in accordance with the contract, the contractor shall, on demand in writing which shall be made within twelve months of the completion of the work from the Engineer-in-Charge specifying the work, materials or articles complained of notwithstanding that the same may have been passed, certified and paid for forthwith rectify, or remove and reconstruct the work so specified in whole or in part, as the case may require or as the case may be, remove the materials or articles so specified and provide other proper and suitable materials or articles at his own charge and cost. In the event of the failing to do so within a period specified by the Engineer-in-Charge in his demand aforesaid, then the contractor shall be liable to pay compensation at the same rate as under clause 8.e. of the general condition of contract in section 9 of tender document (for Compensation for delay) for this default. In such case the Engineer-in Charge may not accept the item of work at the rates applicable under the contract but may accept such items at reduced rates as the Engineer in charge may consider reasonable during the preparation of on

account bills or final bill if the item is so acceptable without detriment to the safety and utility of the item and the structure or he may reject the work outright without any payment and/or get it and other connected and incidental items rectified, or removed and re-executed at the risk and cost of the contractor. Decision of the Engineer-in-Charge to be conveyed in writing in respect of the same will be final and binding on the contractor.

If the penalisation amount exceeds maximum limit with respect to Clause 8.e of Standard General Conditions of Contract, then a show cause notice shall necessarily be issued to the contract as to why the contract should not be terminated.

The above clause is summarized to make it easy to understand as follows:

1. The Engineer-in-charge shall issue notice to the contractor for rectifying the defects or redoing of the work if necessary, within specific time to achieve the desired quality and quantity of the work and this should be governed by clause 8.f and 9.b of Standard General Conditions of Contract.
2. If the contractor fails to comply the same, only then, the contractor shall be liable to pay compensation at the same rate as under clause 8.e of the Standard General Condition of Contract (for Compensation for delay) for this default.
3. If the penalization amount exceeds the maximum limit, then the contractor will be liable for being banned/ deregistered from business dealings with MCGM and this shall be governed by relative provision in Registration Rules of MCGM and Standard General Conditions of Contract.
4. This penalization shall be levied only on account of delay in work, unsound, imperfect or unskillful workmanship or with materials of any inferior description, or that any materials or articles provided by him for the execution of the work are unsound or of quality inferior to that contracted for or otherwise not in accordance with the contract.

86. Contractors remain liable to pay compensation:

In any case in which any of the powers conferred upon the Engineer In-charge by the **relevant clauses** in documents that form a part of contract as exercised or is exercisable in the event of any future case of default by the Contractor, he is declared liable to pay compensation amounting to the

whole of his security deposit. The liability of the Contractor for past and future compensation shall remain unaffected.

In the event of the Executive Engineer taking action against these relevant clauses, he may, if he so desires, take possession of all or any tools and plant, materials and stores in or upon the work of site thereof or belonging to the Contractor or procured by him and intended to be used for the execution of the work or any part thereof paying or allowing for the same in account at the contract rates, or in the case of contract rates not being applicable at current market rates to be certified by the Executive Engineer, may after giving notice in writing to the Contractor or his staff of the work or other authorized agent require him to remove such tools and plants, materials or stores from the premises within a time to be specified in such notice and in the event of the Contractor failing to comply with any such requisition, the Executive Engineer may remove them at the contractors expense or sell them by auction or private sell on account of the Contractor at his risk in all respects and certificate of the Executive Engineer as to the expense of any such removal and the amount of the proceeds an expense of any such sell be final and conclusive against the Contractor.

❖ INTERNAL GRIEVANCE REDRESSAL MECHANISM

B.M.C has formed an Internal Grievance Redressal Mechanism for redressal of grievances. Any Bidder or prospective Bidder aggrieved that any decision, action or omission of the procuring entity being contrary to the provisions of the tender or any rules or guidelines issued therein, in Packet "A", 'B' & 'C' can make an application for review of decision of responsiveness in Packet "A", 'B' & 'C' within a period of 7 days or any such other period, as may be specified in the Bid document .

While making such an application to procuring entity for review, aggrieved bidders or Prospective bidders shall clearly specify the ground or grounds in respect of which he feels aggrieved.

Provided that after declaration of a bidder as a successful in Packet 'A' (General Requirements), an application for review may be filed only by a bidder who has participated in procurement proceedings and after

declaration of successful bidder in Packet 'B' (Technical Bid), an application for review may be filed only by successful bidders of Packet 'A'. Provided further that, an application for review of the financial bid can be submitted, by the bidder whose technical bid is found to be acceptable / responsive.

Upon receipt of such application for review, B.M.C. may decide whether the bid process is required to be suspended pending disposal of such review. The B.M.C after examining the application and the documents available to him, give such reliefs, as may be considered appropriate and communicate its decision to the Applicant and if required to other bidders or prospective bidders, as the case may be.

B.M.C shall deal and dispose off such application as expeditiously as possible and in any case within 10 days from the date of receipt of such application or such other period as may be specified in pre-qualification document, bidder registration document or bid documents, as the case may be.

Where B.M.C. fails to dispose off the application within the specified period or if the bidder or prospective bidder feels aggrieved by the decision of the procuring entity, such bidder or prospective bidder may file an application for redressal before the 'Internal Procurement Redressal Committee' within 7 days of the expiry of the allowed time or of the date of receipt of the decision, as the case may be. Every such application for internal redressal before Redressal Committee shall be accompanied by fee of Rs.25,000/- fee shall be paid in the form of D.D. in favour of M.C.G.M.

1st Appeal by the bidder against the decision of C.E./HoD/Dean can be made to concerned D.M.C/Director who should decide appeal in 7 days. If not satisfied, 2nd Appeal by the bidder can be made to concerned A.M.C.for decision .

Grievance Redressal Committee (GRC) is headed by Concerned D.M.C/Director of particular department for the first appeal / Grievances by the bidder against the decision for responsiveness / Non-Responsiveness In Packet 'A', Packet 'B' or Packet 'C' and if not satisfied, Concerned A.M.C. will take decision as per second appeal made by the bidder.

This Grievance Redressal Committee (GRC) will be operated through DMC (CPD) office where appeals of aggrieved bidder will be received with fee

of Rs.25000/-from aggrieved bidder.The necessary correspondence in respect of said applications to the aggrieved bidder & concerned department ,issuing notices, arranging of Grievance Redressal Committee(GRC) with D.M.C.and further proceeding will be carried out through registrar appointed by B.M.C.

No application shall be maintainable before the Redressal Committee in regard of any decision of the B.M.C. relating to following issues:-

- i) Determination of need of procurement
- ii) The decision of whether or not to enter into negotiations.
- iii) Cancellation of a procurement process for certain reasons.

On receipt of recommendation of the Committee, It will be communicate his decision thereon to the Applicant and to the Committee within 10 days or such further time not exceeding 20 days, as may be considered necessary from the date of receipt of the recommendation and in case of non-acceptance of any recommendation, the reason of such non-acceptance shall also be mentioned in such communication.

Additional Municipal Commissioner and/or Procurement Redressal Committee, if found, come to the conclusion that any such complaint or review is of vexatious, frivolous or malicious nature and submitted with the intention of delaying or defeating any procurement or causing loss to the procuring entity or any other bidder, then such complainant shall be punished with fine, which may extend to Five Lac rupees or two percent of the value of the procurement, whichever is higher

87. No Claim To Any Payment Or Compensation Or Alteration In Or Restriction Of Work

a) If at any time after the execution of contract documents, the Engineer shall for any reason whatsoever, desires that the whole or any part of the works specified in the Tender should be suspended for any period or that the whole or part of the work should not be carried out, at all, he shall give to the Contractor a Notice in writing of such desire and upon the receipt of such notice, the Contractor shall forthwith suspend or stop the work wholly

or in part as required after having due regard to the appropriate stage at which the work should be stopped or suspended so as not to cause any damage or injury the work already done or endanger the safety thereof, provided that the decision of the Engineer as to the stage at which the work or any part of it could be or could have been safely stopped or suspended shall be final and conclusive against the contractor. The Contractor shall have no claim to any payment or compensation whatsoever by reason of or in pursuance of any notice as aforesaid, on account of any suspension, stoppage or curtailment except to the extent specified hereinafter.

b) Where the total suspension of Work Order as aforesaid continued for a continuous period exceeding 90 days the contractor shall be at liberty to withdraw from the contractual obligations under the contract so far as it pertains to the unexecuted part of the work by giving 10 days prior notice in writing to the Engineer within 30 days of the expiry of the said period of 90 days, of such intention and requiring the Engineering to record the final measurement of the work already done and to pay final bill. Upon giving such Notice, the Contractor shall be deemed to have been discharged from his obligations to complete the remaining unexecuted work under his contract. On receipt of such notice the Engineer shall proceed to complete the measurement and make such payment as may be finally due to the contractor within a period of 90 days from the receipt of such Notice in respect of the work already done by the contractor. Such payment shall not in any manner prejudice the right of the contractor to any further compensation under the remaining provisions of this clause.

c) Where the Engineer required to Contractor to suspend the work for a period in excess of 30 days at any time or 60 days in the aggregate, the Contractor shall be entitled to apply to the Engineer within 30 days of the resumption of the work after such suspension for payment of compensation to the extent of pecuniary loss suffered by him in respect of working machinery remained ideal on the site of on the account of his having to pay the salary of wages and labour engaged by him during the said period of suspension provided always that the contractor shall not be entitled to any claim in respect of any such working machinery, salary or wages for the first 30 days whether consecutive or in the aggregate or such suspension or in

respect of any such suspension whatsoever occasion by unsatisfactory work or any other default on his part, the decision of the Engineer in this regard shall be final and conclusive against the contractor.

88. Contractor to supply equipment etc required to carry out the work and is liable for damages arising for its non provision

The Contractor shall supply at his own cost all material, plant, tools, appliances, implements, equipments, vehicles requisite or proper for the proper execution of the work, whether, in the original altered or substituted form and whether included in the specification of other documents forming part of the contract or referred to in these conditions or not and which may be necessary for the purpose of satisfying or complying with the requirements of the Eng-In-Charge as to any matter as to which under these conditions is entitled to be satisfied, or which is entitled to require together with the carriage therefore to and from the work.

The Contractor shall also supply without charge, the requisite number of person with the means and materials necessary for the purpose of setting out works and counting, weighing and assisting in the measurements of examination at any time and from time to time of the work or materials, failing which the same may be provided by the Engineer In-charge at the expense of the contractor and the expenses may be deducted from any money due to the contractor under the contract or from his security deposit or the proceeds of sale thereof, or offers sufficient portion thereof.

The contractor shall provide all necessary measures & precautions to protect the public from accident and shall also be bound to bear the expenses of defence of every suit, action or other legal proceedings, that may be brought by any person for injury sustained owing to neglect of the above precautions and to pay any damages and cost which may be awarded in any such suit action or proceedings to any such person or which may with the consent of the contractor be paid for compromising any claim by any such person.

89. Prevention of Fire:

The contractor shall not set fire to any standing jungle, trees, brushwood or grass or waste.

Contractor shall take necessary measures to prevent fire and its spreading to surrounding properties.

90. Compensation for all damages done intentionally or unintentionally by contractor whether in or beyond the limits of BMC property including any damage caused by spreading the fire shall be estimated by the Engineer In-charge or such other officer as he may appoint and the estimate of the Engineer in-charge to the decision of the Dy. Chief Engineer on appeal shall be final and the contractor shall be bound to pay the amount of the assessed compensation on demand failing which the same will be recovered from the Contractor as damages or deducted by the Engineer In-charge from any sums that may be due or become due from BMC to contractor under this Contract or otherwise. Contractor shall bear the expenses of defending any action or other legal proceedings that may be brought to prevent the spread of fire and he shall pay any damages and costs that may be awarded by the Court in consequence.

91. In the case of Tender by partners, any change in the constitution of the firm shall be forthwith, notified by the contractor through the Engineer In-charge for his information.

92. Action where no specifications:

In the case of any class of work for which there are no such specifications, such works shall be carried out in accordance with the specifications and in the event of there being no such specifications, then in such case, the work shall be carried out in all respects in accordance with all instructions and requirements of the Engineer In-charge.

93. Safety and medical help:

(i) The Contractor shall be responsible for and shall pay the expenses of providing medical help to any workmen who may suffer a bodily injury as a result of an accident. If such expenses are incurred by BMC, the same shall be recoverable from the contractor forthwith and be included without prejudice to any other remedy of BMC from any amount due or that may become due to the Contractor.

(ii) The contractor shall provide necessary personal safety equipment and first-aid box for the use of persons employed on the site and shall maintain the same in condition suitable for immediate use at any time.

(iii) The workers shall be required to use the safety equipments so provided by the contractor and the contractor shall take adequate steps to ensure the proper use of equipments by those concerned.

(iv) When the work is carried on in proximity to any place where there is risk or drawing all necessary equipments shall be provided and kept ready for use and all necessary steps shall be taken for the prompt rescue of any person in danger.

94. Anti-malaria and other health measures:

Anti-Malaria and other health measures shall be taken as directed by the Executive Health Officer of BMC. Contractor shall see that mosquitogenic conditions are created so as to keep vector population to minimum level. Contractor shall carry out anti-malaria measures in the area as per the guidelines issued by the Executive Health Officer of BMC from time to time.

In case of default, in carrying out prescribed anti-malaria measures resulting in increase in malaria incidence, contractor shall be liable to pay BMC on anti-malaria measures to control the situation in addition to fine.

SECTION 10 SPECIFICATIONS

SPECIFICATIONS

Subject: Manufacturing & Supply of refuse collection storage facility and enclosures at various locations in the wards of Mumbai.

1) Preamble:-

The 1.1 Cu. Mt capacities M. S. Refuse Bins are used for temporary storage of refuse where generation of waste in higher frequency such as high footfall areas, vegetable market, goods market, near stations. Temporary storage and collected waste being emptied into refuse vehicles by using universal lifting mechanism. In this system of collection and transfer of refuse, manual handling is so far eliminated. There is requirement of 1.1 Cu. M. capacity refuse bins from various wards to avoid open dump and overflowing of bins.

Brihanmumbai Municipal Corporation (B.M.C) proposes to invite e-tenders from the experienced firms dealing in this line for supply of 1.1 Cu. M. capacity M.S. sheet refuse bins suitable for lifting and tipping by compactors universal bin lifting mechanism operated by BMC & Private contractors. Along with manufacturing contractor has to delivered the bins at the collection spot or as directed by individual wards across the Mumbai.

Moreover it is also proposed to provide SS enclosure to the 1.1 Cu. M. bin at various possible collection points in Mumbai to provide aesthetic improvement of location, no eyesore of garbage in public, avoid water accumulation during rainy days.

Therefore the scope of the work involves

- a) Manufacturing & Supply of 1.1 Cu. M. bins as per specification-1300 Nos.

- b) Manufacture, supply and Installation of SS enclosure for 1.1 m³ container -100 Nos.

2) Contract Period:

- i) The Contract Period is for **one year (365 days)** from actual date of start of work. However, the contractor should start the work from the date mentioned in Letter of acceptance (LOA).
- ii) Contractor shall have to finish all the formalities like inspection of sample, testing/trial of sample of field, approval of sample, Submission & approval of detailed drawing within 30 days from actual date of start of work.
- iii) The Contractor shall be required to carry out the modifications after the field trials as may be required without any extra cost. The prototype/sample shall be included in the total quantity.

3) Quantity of Bins:-

- Total 1.1 Cu. M. bins required -1300 nos.
- SS enclosure for 1.1 m³ container-100 nos.
- The exact quantity of bins required for Dry Waste (Blue Colour) & Wet Waste (Green Colour) shall be provided as demanded by BMC ward Engineers. Contractor has to collect the requirement from wards after receipt of LOA.

4) Warranty:-

For 1.1 Cu. M. Bin

- The contractor should give one year warranty for replacement of defective bins or any part, if the bins are found defective due to manufacturing defects, poor workmanship or sub-standard material. Such bins should be replaced free of cost. The one year warranty will be calculated from the date of delivery.

- Warranty of wheel and swivel caster assembly for free replacement in case of any damage and breakage due to any manufacturing defect only such as developing cracks in the wheel assembly, porosity.

For Enclosure

The contractor should give one year warranty for replacement of defective Enclosure or any part, if the Enclosure are found defective due to manufacturing defects, poor workmanship or sub-standard material. Such enclosure should be replaced free of cost. The one-year warranty will be calculated from the date of installation.

5) Technical Specifications:

A. Specifications for 1.1 m³ Bins

- i) The dimensions of the bins shall be as per the accompanied detail drawing and details mentioned below:

Dimensions of containers

Length of the bin	1210 mm (± 3 %)
Width of the bin	1040 mm (± 3 %)
Height of the bin	1225 mm (including the height of Wheels) (± 3%)

ii) Materials to be use for manufacturing of the bins:-

Following are the tentative material to be used for fabrication & manufacturing of M S bin, However contractors responsibility to access material to be required toward completion of job.

- a) 3 mm thick steel sheet from reputed company's i.e SAIL/ Tisco/ Essar/ Jindal or any equivalent etc to manufacture Main container body of the bin.

- b) Test Certificate of material should be submitted be provided at the start of work.
- c) FRP lid- 2 nos.
- d) Ms angle 40X40X5 mm thick for bottom frame- 7nos.
- e) The bin shall have forged lifting pin (trunnion) of size 36 mm (+/- 2 mm) dia M.S. with end flange (M.S. stopper) of 63 mm. dia and 6 mm thick plate at both sides- 2 nos.
- f) M.S plate of size 150mm X 150 mm X 5 mm thick as inner plate for pin (trunion) per bin- 2 nos.
- g) Gusset plates of 6 mm thick of size 60x60 for top bend support-12 nos
- h) Gusset plates of 6 mm thick of size 60x 60 for bottom support- 4 nos
- i) Gusset plate for handle of 3 mm thick -4 nos.
- j) Vertical M. S. Stiffener of size 50x15X300mm length and 3 mm thickness- 4 nos.
- k) Lifting pin support C channel from outside of size 75X40X280 mm length having thickness of 5 mm- 2 nos
- l) M.S. Handle from 10 mm rod- 4 nos.
- m) Ms bend 3 mm thick of size 150X150 mm half round on top surface – 4 nos
- n) Ms round bar inside top corner bend of 32 mm dia X 200 mm length top surface- 4 nos.
- o) Four wheels made of one piece UHMW-PE (Ultra High Molecular Weight- Polyethylene) of 200 mm dia. and shall have swiveling assembly which rotate through 360 degree.
- p) Wheel bracket of size 150 X 115 X 8 mm thick- 4 nos
- q) Lid bracket – 4 nos
- r) Hinge support with supporting pipe for lead and required fastners.
- ⊕ Hexagonal bolt with nut and washers (M 12x 50 long)-16 nos, or required fastners to complete the job-

iii) Procedure to manufacture the bins

a) Main Container Body:

1. The containers shall be manufactured by using 3 mm thick sheet steel manufactured from reputed company's i.e SAIL/Tisco/Essar/ Jindal make only.
2. Bottom plate shall be of 3 mm thick and it is formed with two longer sides and top frame all in one single sheet.
3. Two nos. of Smaller side plate shall be formed with 25 mm collar bend at all three sides (bottom & two sides)
4. The joining of four vertical sides metal sheets shall be by Lap joints carried out by MIG welding process.
5. There shall be sufficient reinforcements by same sheet forming by embossing the suitable ribs, so as to take jerks induced during loading / unloading garbage into compactors.
6. The vertical sheets shall have 2 horizontal ribs and 5 vertical ribs on longer side and 2 horizontal ribs and 3 vertical ribs on smaller side of suitable deep self formed by embossing the same sheet. All the ribs shall be protruding outside the bin surface.
7. Top frame shall be formed the shape of pipe of 40 mm OD by suitably shaping the vertical sides of M.S. sheet.
8. The constructional details shall be as per the attached drawing.
9. The other sections such as angles, round bars etc. shall be of first grade and of approved quality.
10. All the welding work has to be carried out by MIG welding process only. To maintain the high degree of accuracy and uniformity without damaging mechanical or chemical properties.

b) Top Edge Frame :

1. Top edge frame shall be tube shaped made of 3 mm thick sheet steel formed in the same vertical sides as already explained in (a) above.
2. The top four edges of the round pipe of container shall be first joined by using M.S. rod of 32 mm (minimum) dia to match the I. D. of top piped frame.
3. Minimum 100 mm long rod shall be projected inside the piped frame.
4. The rod shall be given 'L' shape by properly bending & then inserted into corners of piped frame & then welded. The joint at the corner of L shape reinforcement should be avoided.
5. The four top corner joints shall be further strengthened by providing half round (ID matching the OD of the pipe frame) 'L' shaped tie formed by pressing 3 mm M.S. sheet. The total length of 'L' shaped tie shall be 150 mm on each outside portion of the corner.
6. The top piped frame shall be further supported by welding triangular stiffeners/gussets of 6 mm thick plate. There shall be four nos. & two nos. of stiffeners / gussets on long side & short side respectively.

c) Collar :-

The smaller side plate of the bin should have collar of 25 mm width on both sides and bottom for lap joint to make overlap of 25 mm with longer side plate.

d) Lid:-

The container shall have **2** nos of FRP (Fiber reinforced Plastic) lid hinged at one end which shall open freely while unloading.

The material shall be resistant to waste water and chemicals.

The design of hinge shall be as per the requirement of lid opening. The **weight of the single lid** shall not be less than **3 kg**.

e) Side Lifting Trunnion (Pin): -

The bin shall have two side lifting Trunnion compatible for being lifted by universal bin lifters mechanism of the refuse vehicles.

The lifting Trunnion shall be 36 mm (+/- 2 mm) dia M.S. with end flange of M.S. stopper of 63 mm. dia and 6 mm thick plate shall be provided by welding for preventing the accidental fall of bins. Suitable pin holding inner plate shall be welded to the bin firmly from inside and channel from outside by welding to vertical side as well as top frame. Trunnions are fixed by passing through pin holding inner plate, bin side wall C channel by suitably welding. Trunnions must protrude 5 mm. inside the holding plate by MIG welding.

f) Holes for draining:-

For proper draining of water, leachate etc. arrangement shall be made by providing 6 Nos. of 20 mm dia. drain holes. The holes should be drilled at the bottom as shown or as directed.

g) MIG (Metal Inert Gas) welding process:-

Unless it is specified otherwise or as directed, all welding work shall be carried out by MIG welding process as per prevailing standards by continuous welding from inside & outside & shall be free from welding defects, sharp edges & burrs etc.

h) Stiffeners / Gusset plates:-

Sufficient stiffeners / gusset plates shall be provided between the top frame and the main body.

i) Bin Pulling system:-

The bins are always full of garbage. Hence to avoid direct contact of labours with these bins, the Pulling mechanism shall be provided for smooth operation for unloading of the bins. The MS material of suitable strength shall be used to fabricate such Mechanism. Only cost of bin pulling system is included in this tender. The Handle / arm is required to operate this mechanism shall be purchased afterward as per requirement of sites.

The demonstration of the said provision shall be given before opening of packet C, Within 3 days after opening of packet A and Packet B.

j) Construction Design:-

The overall construction shall be designed as per applicable prevailing standards of manufacturing, fabrication, welding of bins. Successful contractor shall also refer the existing bin at ward/ field as sample for manufacturing & fabrication in consultation with BMC Engineer.

The wheels castors, sheet material, lifting Trunions (Pin), cover & other parts shall be extra strong to withstand heavy and rough operations and impact loads. Metal stiffeners on vertical

sides shall be provided as per drawing for extra safety to avoid smashing and damaging of the container body.

k) Wheels: & Swivel Wheel Assembly -

1. The bin shall have rest on four wheels made of one piece UHMW-PE (Ultra-high-molecular-weight polyethylene) by of 200 mm dia. x 50mm width and shall have swiveling through 360 degree.
2. Overall dimensions of wheel are as under: -
 - Diameter of the wheel - 200 mm,
 - Width of wheel - 50 mm,
 - Width of Hub - 56 mm,
 - O.D. of hub - 84 mm
3. The wheels shall be manufactured by compression molding method from virgin UHMW-PE powder white in colour.
4. Heavy duty **forged** swivel type castors with white UHMW-PE (Ultra High Molecular Weight Polyethylene) wheels shall be fabricated.
5. Test Certificate of wheel should be submitted be provided at the start of work mentioning load carrying capacity, material and manufacturing method.
6. There shall be a M. S. (Metal insert) sleeve of size of 60 mm O.D., 52 mm I.D. & 56 mm long pressed into wheel and 2 Nos. of ball bearings having both side covers & circular clip to prevent the ball bearings coming out from both the ends.
7. The swiveling assembly shall be painted for protection against corrosion.
8. Two front wheel shall have locking/ bracking system to prevent the bin movement kept at sloppy ground.
9. **Heavy duty swivel mechanism** -

This assembly shall be formed by using good quality forged steel, chrome plated carbon steel balls, brass grease nipple, locking pin, 2 Nos. of 8 mm thick brackets, 2 nos. of dust covers, cotter pin, etc.

The overall height with 200 mm dia. Wheel	= 255 mm
Offset of wheel	= 60 mm
Plate Size	= 150 x 115 mm
Hole Distance	= 120 x 60 mm
Top plate thickness	= 8 mm (Rectangle Shape)

10. Brackets;- There shall be two nos. of 8 mm thick brackets to hold the wheel.
11. The castor wheel assembly shall be first fitted by nut bolts & then the castor wheel assembly fixed plate shall be welded to bottom plate from all sides firmly.
12. Suitable base frame shall be fabricated by using 40 x 40 x 5 mm M.S angle. The wheel frame and bottom of the bin shall be fastened by using 4 nos. of bolts and nuts of size 12 mm dia. for each wheel with suitable washers on both sides. The bolt should protrude minimum 5 mm outside the nut after fully tightened. The nut bolts shall be suitably tack welded to prevent damages, stealing by antisocial elements. The wheel base frame and bins bottom shall be held together by welding intermittently to each other or continuously as directed. All the sharp corners

to be grinded for smooth finish and aesthetic look.

13. Brands acceptable to B.M.C

- 1) Ratan
- 2) Akash Engineers
- 3) Rexello
- 4) Pioneer
- 5) Khushi

Or any other brand approved by **Chief Engineer (SWM) Department.**

14. However, the contractor shall submit the authorisation of the Wheel Manufacturer along with the tender. If Authority letter is not submitted the Packet C will not be opened and tender shall be treated as rejected.

iv) Painting process:-

1. After complete fabrication process, and before painting, the container body shall be, thoroughly cleaned, de-scaling & degreasing to remove foreign particles.
2. Thereafter, the complete container shall be painted with 2 coats of anticorrosive Epoxy primer paint and two coat of anticorrosive epoxy paint as per prevailing standard-outside of container.
3. Inside Painting:- The inside body of container shall be painted with two coats of black anticorrosive/ epoxy paint.
4. Outside Body:-
For Dry Waste:- The container using for Dry Waste shall be painted with Blue colour paint or as directed.
For Wet Waste:- The container using for Wet Waste shall be painted with green colour paint or as directed.
5. Quality of paint & Brands:- The paint shall be of Good Quality

and of ICI/Asian/Johnson & Nicholson /British/Burger or as approved by site Engineer

6. Finishing:- After completion of painting work, the bins shall be finished and lettering and other work shall be carried out as mentioned or as directed.
7. Inspection shall be carried out from Engineer in charge before and after painting of the bins.

1) Lettering Work:-

Necessary lettering work shall be carried out as directed such as serial number, Ward, B.M.C., Type of use, Logo, Date of supply, slogan etc. The date of supply shall also be punched at the trunion holding channel. The serial nos. of containers shall be engraved as well as painted at specified location.

B) Specifications to Fabricate, Supply and install SS enclosure for

1.1 Cu. M Container

- i) Material and general specification
 - a) The lot of garbage is spread up on collection spots and the garbage is also overflowing from the bins which creates an ugly and unhygienic conditions at the collection spots. To overcome this situation, it is proposed to provide enclosure to 1.1 M³ bins which will avoid Eyesore. Therefore contractor shall visit the each collection spot, survey the site and install the enclosure in consultation of the A.E.(SWM)ward.
 - b) Tenderer shall design suitable enclosure for accommodating one number of 1.1 m³ bin along with frame and RCC platform.
 - c) All the walls, doors, superstructure and supporting frame shall be made of SS 202 material or above grade.
 - d) Superstructure of enclosure shall be made up of 50X50X2 mm square SS 202 pipe.

- e) Supporting frame work shall be made up of 25X25X1.6 mm SS 202 pipe.
- f) The enclosure shall be provided with clear inside space to accommodate 1100 Lit bin along with approx. 100 mm clearance from all side.
- g) The roof top shall be projected out of the super structure at least 100 mm on three sides and 25 mm on rear side.
- h) The height of the enclosure shall be selected to have clear opening of 700mm in front side above the container height for easy unloading of various types of house hold bins into container.
- i) The backside of Enclosure shall have opening of around 250 mm height.
- j) Front door shall be made up of SS frame work of 25x25x1.6 mm and SS sheet of 1 mm shall be specially structured for aesthetics look.
- k) The side and back walls shall be made of SS frame work of 25x25x1.6 mm and SS sheet of 1 mm shall be specially structured for aesthetic look.
- l) The front side of the enclosure shall be provided with openable doors in to two halves for easy removal of bins.
- m) All other sides of enclosure shall be aesthetically designed to cover at least 90% height of 1.1 cum bin.
- n) The side walls and doors shall be designed to have proper ventilation.
- o) Sufficient opening shall be provided on front side such that after opening the door it ensures easy maneuvering of the container.
- p) 03 numbers of heavy-duty SS hinges shall be provided to each door. The opening angle of door shall be more than 120°.
- q) The door shall be provided with suitable locking mechanism.
- r) The entire structure shall be provided with aesthetically designed arc shaped roof for easy draining out of rain water towards the back side of the Bin.

- s) To display clean up messages on the front side of roof, it shall be provided with the flat board of height 250 mm from the top and to the full width of the roof. The message shall be given by BMC and stickering work of the same shall be carried out by the contractor.
- t) Both the side of the roof shall be aesthetically covered to prevent visibility of garbage from side.
- u) The flooring of the enclosure shall be made up of prefabricated RCC platform of M 150 grade having height of min. 75mm with 6mm steel bar for reinforcement.
- v) Platform shall be projected out of the enclosure area on front side up to 500mm with a gentle slope for easy removal of bin. The projected portion of slab shall have gradual slope so as to have a height of 25 mm at the front end.
- w) The platform shall have provision of anchoring of super structure which shall be design in such way that the super structure and platform can be shifted from one place to other place easily in SKD condition.
- x) The design will be approved by BMC and any subsequent minor changes required will be informed to the contractor with the approval of Engineer of the contract, for which contractor shall be ready without any extra cost.
- y) The enclosure shall be designed to accommodate one 1.1 m³ Bin. The contractor shall arrange number of Enclosures at one location as per direction of site Engineer.

ii) Installation

The contractor shall carryout installation of entire enclosure at the site at various wards. The scope of work of installation is as below:

- a) The entire enclosure and RCC platform shall be brought to site in SKD condition.
- b) The platform shall be brought to the site in one piece in fully cast condition.
- c) A.E.(SWM) ward will give the place with minor levelling, cleaning, compaction of flooring.
- d) The precast platform shall be placed on the flooring and other structure shall be assembled at site by the contractor.
- e) After complete installation the contractor shall give a trial of the system to BMC officers.
- f) Contractor shall arrange required tools, equipment, welding plant, gas cutting, Dg set, etc for site work. The cost for which shall be born by the contractor.

6) Delivery Details:

i) Delivery Schedule:

The completion/ supply period from date of issuing part P.O.,

For 1.1 Cu. M bin

- a) If P.O. quantity is 100 nos. or less, then supply shall be within 35 days of that PO ,
- b) If P.O. quantity is more than 101 and up to 200 nos., then entire supply shall be within 50 days for that part PO quantity.
- c) If P.O. quantity is more than 201 and up to 300, then entire supply shall be within 60 days for that PO quantity.
- d) The maximum no of Quantity per part P.O. shall not exceed 300 nos.

For Encloser

- a) If P.O. quantity is 10 nos. or less, then supply shall be within 40 days from the date of handing over of site.
- b) If P.O. quantity is more than 10 and up to 20 nos. then entire supply shall be within 80 days from the date of handing over of site.
- c) The maximum no of Quantity per part P.O. for Enclosure shall not exceed 20 nos.

Contract period is of one year and as and when required within the contract period, part P.O. will be issued to the contractor for supply of bin as well as Enclosures. At a time only one part PO will be issued.

ii) Delivery Site:

For 1.1 Cu. M bin & enclosure

- a) The supply of the bins & enclosure shall be made at given location within Brihanmumbai limits i.e. City, Western & Eastern Subs. without any extra cost.
- b) Delivery of 1.1 Cu. M. Capacity M.S. refuse bins & enclosure shall be made at A.E.(SWM) of respective wards or at various sites as directed by A.E.(SWM) of respective wards. Cost of all transportation shall be included in offer.

7) Inspection and trials of bins:-

- i) The Contractor shall offer sample of 1.1 Cu. M. Capacity M. S. refuse bin for inspection within 15 days from the date of start of work.
- ii) After receipt of LOA the successful contractor shall manufacture 1 number of enclosures with precast platform as a prototype and shall be offered for the inspection to

BMC officers within 15 days.

- iii) The contractor shall manufacture balance quantity of enclosure as per approved prototype unit.
- iv) Inspection at manufacturing place at various stages will be decided after the production schedule is finalized. All expenses towards this shall be borne by the Contractor.
- v) After final inspection, the list of individual delivery sites will be given by BMC. It will be the responsibility of bidders to deliver each and every container to the site. Actual delivery date shall be reckoned as date of delivery on individual site.
- vi) Testing -Each castor wheel assembly shall be capable of taking minimum 500 Kg. load. Necessary test certificate for same shall be produced.

8) Trial of 1.1 Cu. M. capacity M.S. Refuse Bin/Container: -

- i) The contractor should give satisfactory trial of containers by using B.M.C's compactors at one of the garages/sites.
- ii) The dimensions, specifications, drawings given here are close to the existing containers. On inspection of sample or in case of any difficulty in handling the containers by the compactors, necessary modifications, alterations has to be carried out free of cost to suit the operations as directed by the office of Dy. Ch. E(S.W.M) Planning.
- iii) If required Maximum 10% modifications in weight & designing and strengthening of the containers shall have to be carried out by the contractor subject to the approval of Engineer. Fabrication allowance of (+)/(-) 3% in all dimensions is admissible only in case of practical

difficulties. No tolerance in the sheet thickness is permitted.

9) Payment: -

For 1.1 Cu. M bin

- i. The contractor shall raise the invoice against the supply of minimum 50 number of containers against the Purchase Order. 95% of bill will be paid after the supply of containers against the raised invoice and remaining 5 % will be paid against satisfactory completion of work or completion of one year warranty period whichever is later.
- ii. The contractor shall submit the Invoice with acknowledged delivery challans against supply of M.S. bins to (SWM) Planning Office.
- iii. If the poor performance of bins and defects observed during contract period only subject to manufacturing defect, such as:-
 - Crack develop in the wheel assembly because of manufacturing defect.
 - Peeling of painting of container.
 - Crack developed in the container handle.
 - Deformation developed in the shape of container due to poor workmanship.

The proportion with the defective quantum will be deducted from the contractors bills.

For Enclosure

- i. The contractor shall raise the invoice against the supply of Enclosure against the Purchase Order. 95% of bill will be paid after the supply of Enclosure against the raised invoice and remaining 5 % will be paid against satisfactory completion of work or completion of one year warranty period.

- ii. The contractor shall submit the Invoice with acknowledged delivery challans, Installation report against supply of Enclosure to (SWM) Planning Office.

10) Submission of Drawing:-.

- i) The Contractor shall be required to submit the detailed drawing of the containers and enclosure within 7 days after issuance of LOA. The detailed technical and dimensional drawing shall be scrutinized by the engineers of the dept. and shall be approved.
- ii) The detailed technical and dimensional drawing shall be scrutinized by the engineers of the dept. and shall be approved. However, such approval shall not absolve the bidders from the performance of the Enclosure as per the contract conditions.
- iii) The drawing should contain the general necessary details such as material, thickness, wheels etc. mentioned in the BOQ table.

11) Special instruction to Contractor

- i) The rates quoted for Supply of 1.1 Cu. M. Capacity M.S. refuse bins/containers and enclosures as per specification shall be firm and inclusive of all taxes & duties and transportation, loading, unloading, etc. Supply of M. S. Container has include certain small work or services which are incidental or consequential to the supply such as transportation, installation, commissioning, training, maintenance.
- ii) The contractor shall conversant with the volume and scope of work involve in subject work.
- iii) Contractor shall have mechanical workshop in MMR region with manpower, machinery and tools etc. required to carry out the work for successful completion of job.
- iv) The contractor shall follow all relevant Safety, Health and Environment procedures and shall comply with the legal

requirements as per the provisions of various rules and regulation prevailing, as well as factory act. For any mishaps etc. if happened the contractors will be held responsible.

- v) Codes of standard: In case of any conflict between codes / standard and specification, the latter shall prevail and in case of further conflict in this matter, the interpretation of the specifications by the BMC engineer shall be final and binding.
- vi) The contractor shall take photographs with date and time of delivered items of the supply at the site.

12) Special Instruction to wards

- i) The respective A.E.(SWM) shall receive the delivery and take necessary entry in their record/register with acknowledgement on delivery challan.
- ii) The details of the bins shall be keep in record and submit the same to higher authorities as and when required.
- iii) A.E.(SWM) of respective wards shall acknowledged the delivery challans against supply of M.S. bins and submit the same to (SWM) Planning Office.

13) Penalty:

- i) Delay in the offer of inspection of sample of 1.1 Cu. M. capacity M.S. refuse bin/container beyond 15 days from the date of start of work a penalty of Rs.2,500/-per day.
- ii) Delay in submission of detailed technical and dimensional drawing of the 1.1 Cu. M. capacity M.S. refuse bin and Enclosure beyond 7 days from the date of approval of sample of 1.1 Cu. M. capacity M.S. refuse bin/Encloser attracts a penalty of Rs.1,000/-per day.
- iii) If contractor fails to supply any or all the good within the time

period specified in the contract, penalty of ½% per week on delayed material subject to 10% maximum of the value of the goods supplied in that PO.

SECTION 11

Fraud & Corrupt Practices

FRAUD AND CORRUPT PRACTICES

- The Applicants and their respective officers, employees, agents and advisers shall observe the highest standard of ethics during the Bidding Process. Notwithstanding anything to the contrary contained herein, the Authority may reject an Application without being liable in any manner whatsoever to the Applicant if it determines that the Applicant has, directly or indirectly or through an agent, engaged in corrupt practice, fraudulent practice, coercive practice, undesirable practice or restrictive practice in the Bidding Process.
- Without prejudice to the rights of the Authority under relevant Clause hereinabove, if an Applicant is found by the Authority to have directly or indirectly or through an agent, engaged or indulged in any corrupt practice, fraudulent practice, coercive practice, undesirable practice or restrictive practice during the Bidding Process, such Applicant shall not be eligible to participate in any tender or RFQ issued by the Authority during a period of 2 (two) years from the date such Applicant is found by the Authority to have directly or indirectly or through an agent, engaged or indulged in any corrupt practice, fraudulent practice, coercive practice, undesirable practice or restrictive practice, as the case may be.
- For the purposes of this Clause, the following terms shall have the meaning hereinafter respectively assigned to them:

A. “corrupt practice” means

the offering, giving, receiving, or soliciting, directly or indirectly, of anything of value to influence the actions of any person connected with the Bidding Process (for avoidance of doubt, offering of

employment to, or employing, or engaging in any manner whatsoever, directly or indirectly, any official of the Authority who is or has been associated in any manner, directly or indirectly, with the Bidding Process or the LOA or has dealt with matters concerning the Concession Agreement or arising there from, before or after the execution thereof, at any time prior to the expiry of one year from the date such official resigns or retires from or otherwise ceases to be in the service of the Authority, shall be deemed to constitute influencing the actions of a person connected with the Bidding Process); or save and except as permitted under the relevant sub clause, engaging in any manner whatsoever, whether during the Bidding Process or after the issue of the LOA or after the execution of the Concession Agreement, as the case may be, any person in respect of any matter relating to the Project or the LOA or the Concession Agreement, who at any time has been or is a legal, financial or technical adviser of the Authority in relation to any matter concerning the Project;

B. “fraudulent practice” means a misrepresentation or omission of facts or suppression of facts or disclosure of incomplete facts, in order to influence the Bidding Process;

“Coercive practice” means impairing or harming or threatening to impair or harm, directly or indirectly, any person or property to influence any persons participation or action in the Bidding Process;

D. “undesirable practice” means (i) establishing contact with any person connected with or employed or engaged by the Authority with the objective of canvassing, lobbying or in any manner influencing or attempting to influence the Bidding Process; or (ii) having a Conflict of Interest; and

- E. “Restrictive practice”** means forming a cartel or arriving at any understanding or arrangement among Applicants with the objective of restricting or manipulating a full and fair competition in the Bidding Process.
- F.** If the Employer/Financier determines that the Contractor has engaged in corrupt, fraudulent, collusive, coercive or obstructive practices, in competing for or in executing the Contract, then the Employer may, after giving 14 days’ notice to the Contractor, terminate the Contractor's employment under the Contract and expel him from the Site, and the provisions of relevant Clause shall apply as if such expulsion had been made.
- G.** Should any employee of the Contractor be determined to have engaged in corrupt, fraudulent, collusive, coercive, or obstructive practice during the execution of the Works, then that employee shall be removed in accordance with relevant Clause.

For the purposes of this Sub-Clause:

- i. **“corrupt practice”** is the offering, giving, receiving to soliciting, directly or indirectly, of anything of value to influence improperly the actions of another party;
- ii. **“another party”** refers to a public official acting in relation to the procurement process or contract execution. In this context, “public official” includes Financier staff and employees of other organizations taking or reviewing procurement decisions.
- iii. **“fraudulent practice”** is any act or omission, including a misrepresentation, that knowingly or recklessly misleads, or attempts to mislead, a party to obtain a financial or other benefit or to avoid an obligation;

- iv. **“Collusive practice”** is an arrangement between two or more parties designed to achieve an improper purpose, including to influence improperly the actions of another party;
- v. **“coercive practice”** is impairing or harming, or threatening to impair or harm, directly or indirectly, any party or the property of the party to influence improperly the actions of a party;
- vi. **“obstructive practice”** is deliberately destroying, falsifying, altering or concealing of evidence material to the investigation or making false statements to investigators in order to materially impede the Financier investigation into allegations of a corrupt, fraudulent, coercive or collusive practice; and/or threatening, harassing or intimidating any party to prevent it from disclosing its knowledge of matters relevant to the investigation or from pursuing the investigation; or
- vii. Acts intended to materially impede the exercise of the Financier’s inspection and audit rights provided.
- viii. **“party”** refers to a public official; the terms “benefit” and “obligation” relate to the procurement process or contract execution; and the “act or omission” is intended to influence the procurement process or contract execution.
- ix. **“parties”** refers to participants in the procurement process (including public officials) attempting to establish bid prices at artificial, non-competitive levels.
- x. a **“party”** refers to a participant in the procurement process or contract execution.

SECTION 12

Pre Bid Meeting

PREBID MEETING

~~———— Pre bid meeting of the interested parties shall be convened at the designated date, time and place. A maximum of three representatives of each Applicant shall be allowed to participate on production of authority letter from the Applicant.~~

~~———— During the course of Pre-bid meeting, the Applicants will be free to seek clarifications and make suggestions for consideration of the Authority. The Authority shall Endeavour to provide clarifications and such further information as it may, in its sole discretion, consider appropriate for facilitating a fair, transparent and competitive Bidding Process.~~

SECTION 13
List of Approved Banks

LIST OF APPROVED BANKS

1. The following Banks with their branches in Brihanmumbai and in suburbs and extended suburbs up to Virar and Kalyan have been approved only for the purpose of accepting Banker's guarantee from 1997-98 onwards until further instructions.
2. The Bankers Guarantee issued by branches of approved Banks beyond Kalyan and Virar can be accepted only if the said Banker's Guarantee is countersigned by the Manager of a branch of the same Bank, within the Mumbai Limit categorically endorsing thereon that said bankers Guarantee is binding on the endorsing Branch of the bank within Mumbai limits and is liable to be on forced against the said branch of the Bank in case of default by the contractor/supplier furnishing the bankers Guarantee.

A	S.B.I and its subsidiary Banks
1	State Bank Of India.
2	State Bank Of Bikaner & Jaipur.
3	State Bank Of Hyderabad.
4	State Bank Of Mysore.
5	State Bank Of Patiyala.
6	State Bank Of Saurashtra.
7	State Bank Of Travankore.
B	Nationalized Banks
8	Allahabad Bank.
9	Andhra Bank.
10	Bank Of Baroda.
11	Bank Of India.
12	Bank Of Maharashtra.
13	Central Bank Of India.
14	Dena Bank.

15	Indian Bank.
16	Indian Overseas Bank. Oriental Bank Of Commerce.
18	Punjab National Bank.
19	Punjab & Sindh Bank.
20	Syndicate Bank.
21	Union Bank Of India.
22	United Bank Of India.
23	UCO Bank.
24	Vijaya Bank.
24A	Corporation Bank.
C	Scheduled Commercial Banks
25	Bank Of Madura Ltd.
26	Bank Of Rajasthan Ltd.
27	Banaras State Bank Ltd.
28	Bharat Overseas Bank Ltd
29	Catholic Syrian Bank Ltd.
30	City Union Bank Ltd.
31	Development Credit Bank.
32	Dhanalakshmi Bank Ltd.
33	Federal Bank Ltd.
34	Indsind Bank Ltd.
35	I.C.I.C.I Banking Corporation Ltd.
36	Global Trust Bank Ltd.
37	Jammu & Kashmir Bank Ltd.
38	Karnataka Bank Ltd.
39	KarurVysya Bank Ltd.
40	Laxmi Vilas Bank Ltd.
41	Nedugundi Bank Ltd.
42	Ratnakar Bank Ltd.

43	Sangli Bank Ltd.
44	South Indian Bank Ltd.
45	S.B.I Corporation & Int Bank Ltd.
46	Tamilnadu Mercantile Bank Ltd.
47	United Western Bank Ltd.
48	Vysya Bank Ltd.
D	Schedule Urban Co-op Banks
49	Abhyudaya Co-op Bank Ltd.
50	Bassein Catholic Co-op Bank Ltd.
51	Bharat Co-op Bank Ltd.
52	Bombay Mercantile Co-op Bank Ltd.
53	Cosmos Co-op Bank Ltd.
54	Greater Mumbai Co-op Bank Ltd.
55	JanataSahakari Bank Ltd.
56	Mumbai District Central Co-op Bank Ltd.
57	Maharashtra State Co-op Bank Ltd.
58	New India Co-op Bank Ltd.
59	North Canara G.S.B. Co-op Bank Ltd.
60	Rupee Co-op Bank Ltd.
61	Sangli Urban Co-op Bank Ltd.
62	Saraswat Co-op Bank Ltd.
63	Shamrao Vithal Co-op Bank Ltd.
64	Mahanagar Co-op Bank Ltd.
65	Citizen Bank Ltd.
66	Yes Bank Ltd.
E	Foreign Bank
67	ABM AMRO (N.Y.) Bank.
68	American Express Bank Ltd.
69	ANZ Grindlays Bank Ltd.
70	Bank Of America N.T. & S.A.

71	Bank Of Tokyo Ltd.
72	Bankindosuez.
73	BanqueNationale de Paris.
74	Barclays bank.
75	City Bank N.A.
76	Hongkong & Shanghai banking Corporation.
77	Mitsui Taiyokbe Bank Ltd.
78	Standard Chartered Bank.
79	Cho Hung Bank.

SECTION 14

Appendix

FORM OF TENDER

To,
The Municipal Commissioner for Brihanmumbai
Sir,

I/ We have read and examined the following documents relating to
the work of _____

- i. Notice inviting tender.
- ii. Directions to tenderers (General and special)
- iii. General condition of contract for Works of the Brihanmumbai Municipal Corporation as amended up to date.
- iv. Relevant drawings
- v. Specifications.
- vi. Special directions
- vii. Annexure A and B.
- viii. Bill of Quantities and Rates.

1A. I/We _____
(full name in capital letters, starting with surname), the Proprietor/
Managing Partner/ Managing Director/ Holder of the Business, for the
establishment / firm / registered company, named herein below, do hereby
offer to
.....
.....
.....
.....

Referred to in the specifications and schedule to the accompanying form of
con-tract of the rates entered in the schedule of rates sent herewith and
signed by me/ us” (strike out the portions which are not applicable).

1B. I/We do hereby state and declare that I/We, whose names are given
herein below in details with the addresses, have not filled in this tender
under any other name or under the name of any other establishment /firm
or otherwise, nor are we in any way related or concerned with the
establishment /firm or any other person, who have filled in the tender for
the aforesaid work.”

2. I/We hereby tender for the execution of the works referred to in the
aforesaid documents, upon the terms and conditions, contained or referred

to therein and in accordance with the specifications designs, drawings and other relevant details in all respects.

* At the rates entered in the aforesaid Bill of Quantities and Rates.

3. According to your requirements for payment of Earnest Money amounting to Rs. _____ /-(Rs. _____)

4. I/We have deposited the amount through online payment gateways with the C.E. of the Corporation not to bear interest

I/We hereby request you not to enter into a contract with any other person/s for the execution of the works until notice of non/acceptance of this tender has first been communicated to me/us, and in consideration of yours agreeing to refrain from so doing I/we agree not to withdraw the offer constituted by this tender before the date of communication to me/us of such notice of non/acceptance, which date shall be not later than ten days from the date of the decision of the Standing Committee or Education Committee of the Corporation, as maybe required under the Mumbai Municipal Corporation Act, not to accept this tender.(Subject to condition 5 below).

5. I/We also agree to keep this tender open for acceptance for a period of 180 days from the date fixed for opening the same and not to make any modifications in its terms and conditions which are not acceptable to the Corporation.

6. I/We agree that the Corporation shall, without prejudice to any other right or remedy, be at liberty to forfeit the said earnest money absolutely, if.

a. I/We fail to keep the tender open as aforesaid.

b. I/We fail to execute the formal contract or make the contract deposit when called upon to do so.

c. I/we do not commence the work on or before the date specified by the Engineer in his work order.

7. I/We hereby further agree to pay all the charges of whatsoever nature in connection with the preparation, stamping and execution of the said contract.

8. I/We further agree that, I/we shall register ourselves as 'Employer' with the Bombay Iron and Steel Labour Board' and fulfill all the obligatory provisions of Maharashtra Mathadi, Hamal and other Manual workers (Regulation of Employment and Welfare) Act 1969 and the Bombay Iron and Steel unprotected workers Scheme 1970.

9. "I/We..... have failed in the accompanying tender with full knowledge of liabilities and, therefore, we will not raise any objection or dispute in any manner relating to any action,

including forfeiture of deposit and blacklisting, for giving any information, which is found to be incorrect and against the instructions and directions given in this tender.

10. "I/We further agree and undertake that in the event it is revealed subsequently after the allotment of work/contract to me/us, that any information given by me/us in this tender is false or incorrect, I/We shall compensate the Brihanmumbai Municipal Corporation for any such losses or inconvenience caused to the Corporation in any manner and will not resist any claim for such compensation on any ground whatsoever. I/we agree and undertake that I/we shall not claim in such case any amount by way of damages or compensation for cancellation of the contract given to me/us or any work assigned to me/us or is with-drawn by the Corporation,"

Address
.....
.....

Yours faithfully,

Digital Signature of the Tenderer or the Firm

- 1.....
- 2.....
- 3.....
- 4.....
- 5.....

Full Name and private residential address of all the partners constituting the Firm

A/c No.
.....

- 1. Name of Bank
- 2.
- 3. Name of Branch
- 4.
- 5. Vendor No.
.....

AGREEMENT FORM

Tender / Quotation dated 20....

Standing Committee/Education Committee Resolution No.

CONTRACT FOR THE WORKS.....

This agreement made this day of

Two thousand.....Between.

inhabitants of Mumbai, carrying on business at.....

in Bombay under the style and name of Messrs

.....(Hereinafter called “the contractor of the one part and Shri.....

the D.M.C.(SWM) (hereinafter called “the commissioner” in which expression are included unless the inclusion is inconsistent with the context, or meaning thereof, his successor or successors for the time being holding the office of D.M.C.(SWM) of the second part and the Brihanmumbai Municipal Corporation (hereinafter called “the Corporation”) of the third part, WHEREAS the contractor has tendered for the construction, completion and maintenance of the works described above and his tender has been accepted by the Commissioner (with the approval of the Standing Committee/Education Committee of the Corporation NOW THIS

THIS AGREEMENT WITNESSETH as follows:-

- 1) In this agreement words and expressions shall have the same meanings as are respectively assigned to them in the General Conditions of Contract for works hereinafter referred to:-
- 2) The following documents shall be deemed to form and be read and constructed as a part of this agreement viz.
 - a) The letter of Acceptance
 - b) The Bid:
 - c) Addendum to Bid; if any
 - d) Tender Document
 - e) The Bill of Quantities:
 - f) The Specification:
 - g) Detailed Engineering Drawings

h) Standard General Conditions of Contracts (GCC)

i) All correspondence documents between bidder and BMC

3) In consideration of the payments to be made by the Commissioner to the contractor as hereinafter mentioned the contractor hereby covenants with the Commissioner to construct, complete and maintain the works in conformity in all respects with the provision of the contract.

4) The Commissioner hereby covenants to pay to the Contractor in consideration of the construction, completion and maintenance of the works the contract sum, at times and in the manner prescribed by the contract.

IN WITNESS WHERE OF the parties hereto have caused their respective common seals to be herein to affixed (or have hereunto set their respective hands and seals) the day and year above written.

Signed, Sealed and delivered by the contractors

In the presence of

Trading under the name and style of

Full Name

Address

Contractors

Signed by the D.M.C.(SWM) in the presence of

Ex. E.(SWM)Planning.

D M.C.(SWM)

The Common seal of the Brihanmumbai Municipal Corporation was hereunto affixed on the 20 in the presence of two members of the Standing Committee.

1.

1.

2.

2.

And in the presence of the Municipal Secretary

Municipal Secretary

SECTION 15

ANNEXURES

&

PROFORMAS

Annexure A

Name of Work:- Manufacturing & Supply of refuse collection storage facility and enclosures at various locations in the wards of Mumbai.

Sr. No.	Parameter	Details
1	The Engineer for this work	1.Ch.E.(SWM)
		2.Dy.Ch.E.(SWM)Planning
		3. Ex. Eng.(SWM Planning
2	Description of work	Manufacturing & Supply of refuse collection storage facility and enclosures at various locations in the wards of Mumbai.
3	EMD	Rs. 23,76,400.00
4	Contract Period	One Year (365 days)

Signature of Tenderer/Bidder

Annexure- B

(On Rs. 500/- Stamp Paper)

PRE-CONTRACT INTEGRITY PACT

The Bidder commits himself to take all measures necessary to prevent corrupt practices, unfair means and illegal activities during any stage of his bid or during any pre-contract or post-contract stage in order to secure the contract or in furtherance to secure it and in particular commits himself to the following:-

1. The Bidder will not offer, directly or through intermediaries, any bribe, gift, consideration, reward, favour, any material or immaterial benefit or other advantage, commission, fees, brokerage or inducement to any official of the BMC, connected directly or indirectly with the bidding process, or to any person, organization or third party related to the contract in exchange for any advantage in the bidding, evaluation, contracting and implementation of the Contract.
2. The Bidder further undertakes that he has not given, offered or promised to give, directly or indirectly any bribe, gift, consideration, reward, favour, any material or immaterial benefit or other advantage, commission, fees, brokerage or inducement to any official of the BMC or otherwise in procuring the Contract or forbearing to do or having done any act in relation to the obtaining or execution of the Contract or any other Contract with the Government for showing or forbearing to show favour or disfavour to any person in relation to the Contract or any other Contract with the Government.
3. The Bidder will not collude with other parties interested in the contract to impair the transparency, fairness and progress of the bidding process, bid evaluation, contracting and implementation of the contract.
4. The Bidder will not accept any advantage in exchange for any corrupt practice, unfair means and illegal activities.
5. The Bidder, either while presenting the bid or during pre-contract negotiations or before signing the contract, shall disclose any payments he has made, is committed to or intends to make to officials of the BMC or their family members, agents, brokers or any other intermediaries in connection with the contract and the details of services agreed upon for such payments.
6. The Bidder shall not use improperly, for purposes of competition or personal gain, or pass on to others, any information provided by the BMC as part of the business relationship, regarding plans, technical proposals and business details, including information contained in any electronic data

carrier. The Bidder also undertakes to exercise due and adequate care lest any such information is divulged.

7. The Bidder commits to refrain from giving any complaint directly or through any other manner without supporting it with full and verifiable facts.

8. The Bidder shall not instigate or cause to instigate any third person to commit any of the actions mentioned above.

9. The Bidder and their respective officers, employees, agents and advisers shall observe the highest standard of ethics during the Bidding Process. Notwithstanding anything to the contrary contained herein, the Authority may reject an Application without being liable in any manner whatsoever to the Applicant if it determines that the Applicant has, directly or indirectly or through an agent, engaged in corrupt practice, fraudulent practice, coercive practice, undesirable practice or restrictive practice in the Bidding Process

For the purposes of this Clause 9, the following terms shall have the meaning herein after respectively assigned to them:

7. “fraudulent practice” means a misrepresentation or omission of facts or suppression of facts or disclosure of incomplete facts, in order to influence the Bidding Process ;

8. “coercive practice” means impairing or harming or threatening to impair or harm, directly or indirectly, any person or property to influence any persons participation or action in the Bidding Process;

9. “undesirable practice” means (i) establishing contact with any person connected with or employed or engaged by the Authority with the objective of canvassing, lobbying or in any manner influencing or attempting to influence the Bidding Process; or (ii) having a Conflict of Interest; and

10. “restrictive practice” means forming a cartel or arriving at any understanding or arrangement among Applicants with the objective of restricting or manipulating a full and fair competition in the Bidding Process.

Signature of Tenderer/Bidder

Annexure- C

(On Rs. 500/- Stamp Paper)

DECLARATION CUM INDEMNITY BOND

(Notorised)

I, _____ of _____, do hereby declared and undertake as under.

1. I declare that I have submitted certificates as required to Executive engineer (Monitoring) at the time of registration of my firm/company and there is no change in the contents of the certificates that are submitted at the time of registration.

2. I declare that I _____ in capacity as Manager/Director/Partners/Proprietors of _____ has not been charged with any prohibitory and /or penal action such as banning (for specific time or permanent)/de-registration or any other action under the law by any Government and/or Semi Government and/or Government undertaking.

3. I declare that I have perused and examined the tender document including addendum, condition of contract, specifications, drawings, bill of quantity etc. forming part of tender and accordingly, I submit my offer to execute the work as per tender documents at the rates quoted by me in capacity as _____ of _____.

4. I further declare that if I am allotted the work and I failed to carry out the allotted work in accordance with the terms and conditions and within the time prescribed and specified, BMC is entitled to carry out the work allotted to me by any other means at my risk and cost, at any stage of the contract.

5. I also declare that I will not claim any charge/damages/compensation for non availability of site for the contract work at any time.

6. I declare that I will positively make the arrangements of the required equipment on the day of commencement or with respect to the progress of the work in phases, as per the instructions of site in charge.

Signature of Tenderer/Bidder

BANKERS GURANTEE IN LIEU OF CONTRACT DEPOSIT

THIS INDENTURE made this _____ day of _____ BETWEEN

THE _____ BANK incorporated under the English/Indian Companies Acts and carrying on business in Mumbai (hereinafter referred to as 'the bank' which expression shall be deemed to include its successors and assigns) of the first part _____

inhabitants carrying on business at _____ in Mumbai under the style and name of Messer's _____ (hereinafter referred to as 'the consultant') of the second part Shri. _____

THE MUNICIPAL COMMISSIONER FOR BRIHANMUMBAI (hereinafter referred to as 'the commissioner' which expression shall be deemed, also to include his successor or successors for the time being in the said office of Municipal Commissioner) of the third part and BRIHANMUMBAI MUNICIPAL CORPORATION (hereinafter referred to as 'the Corporation') of the fourth part WHEREAS the consultants have submitted to the Commissioner tender for the execution _____ of the work of

" _____ and the terms of such tender /contract require that the consultants shall deposit with the Commissioner as/contract deposit/ earnest money and /or the security a sum of Rs._ (Rupees _____) AND WHEREAS if and when any such tender is accepted by the Commissioner, the contract to be entered into in furtherance thereof by the consultants will provide that such deposit shall remain with and be appropriated by the Commissioner towards the Security - deposit to be taken under the contract and be redeemable by the consultants, if they shall duly and faithfully carry out the terms and provisions of such contract and shall duly satisfy all claims properly chargeable against them there under AND WHEREAS the consultants are constituents of the Bank and in order to facilitate the keeping of the accounts of the consultants, the Bank with the consent and concurrence of the consultants has requested the Commissioner to accept the undertaking of the Bank hereinafter contained, in place of the contractors depositing with the Commissioner the said sum as earnest money and /or security as aforesaid AND WHEREAS accordingly the Commissioner has agreed to

accept such undertaking NOW THIS AGREEMENT WITNESSES that in consideration of the premises, the Bank at the request of the consultants (hereby testified) UNDERTAKES WITH the commissioner to pay to the commissioner upon demand in writing , whenever required by him , from time to time , so to do ,a sum not exceeding in the whole Rs. (Rupees _____) under the terms of the said tender and /or the contract. The B.G. is valid up to _____”Notwithstanding anything what has been stated above, our liability under the above guarantee is restricted to Rs._____only and guarantee shall remain in force upto_____ unless the demand or claim under this guarantee is made on us in writing on or before _____all your right under the above guarantee shall be forfeited and we shall be released from all liabilities under the guarantee thereafter”

IN WITNESS WHEREOF

WITNESS(1) _____

Name and _____

address _____

WITNESS(2) _____

Name and _____ the duly constituted Attorney Manager
address _____

the Bank and the said Messer's _____

_____ (Name of the Bank)

WITNESS(1) _____

Name and _____

address _____

WITNESS(2) _____

Name and _____

For Messer's _____

Address _____

have here into set their respective hands the day and year first above written.

The amount shall be inserted by the Guarantor, representing the Contract Deposit in Indian Rupees.

Annexure D

Rate Analysis

Item Description

Sr. No.	Description of rate analysis parameters	Unit	Quantity	Rate	Amount
1					
2					
3					
4					
5					
6					
7	Total of all components				
8	Overhead & profit				
9	Total (7+8)				
7	Per unit rate				

Sign & seal of the Tenderer

Annexure E

INFORMATION REGARDING STATUS OF TENDERER

(To be filled in by the tenderer)

(1) (a) Whether it is a proprietor concern	----- -----
(b) If so, name of the owner	----- ----- ----- -----
(2) If it is a partnership concern, please furnish name of each partner and a copy of registration certificate	----- ----- ----- ----- -----
(3) In case of company, please furnish the documentary proof to show that the company is registered	----- ----- ----- ----- -----

Signature of the Authorised Signatory / Signatories:

Name of concerned person(s) / company:

Stamp:

Date:

Annexure F

Name of Work: Manufacturing & Supply of refuse collection storage facility and enclosures at various locations in the wards of Mumbai.

EARNEST MONEY DEPOSIT (To be filled in by the tenderer)

1	Amount of E.M.D.	:	Rs. 23,76,400.00
2	Contract Period	:	1 year (365 days)

**Signature of authorized Signatory
of company**

Annexure G

DETAILS OF LITIGATION HISTORY

1) I M/s participating in the above subject Bid, here by declared that there is no litigation history against me during the last 5 years, prior to due date of the tender.

Or

2) I M/s participating in the above subject Bid, here by declared that the litigation history against me during the last 5 years, prior to due date of the tender, is as under

Sr. No	Year	Action taken	Name of the Organization	Remarks
1.				
2.				
3.				
4.				
5.				

I further declared that information furnished above is correct, and in future, if BMC finds that information disclosed is false or incomplete, then BMC can directly disqualify my bid and can initiate penal action including blacklisting of the firm.

**Full Signature of the tenderer with
Official Seal and Address**

ANNEXURE H

GRIEVANCE REDRESSAL MECHANISM

B.M.C has formed an Internal Grievance Redressal Mechanism for redressal of bidder's grievances. Any Bidder or prospective Bidder aggrieved by any decision, action or omission of the procuring entity being contrary to the provisions of the tender or any rules or guidelines issued therein, in Packet "A", 'B' & 'C' can make an application for review of decision of responsiveness in Packet "A", 'B' & 'C' within a period of 7 days or any such other period, as may be specified in the Bid document.

While making such an application to procuring entity for review, aggrieved bidders or Prospective bidders shall clearly specify the ground or grounds in respect of which he feels aggrieved.

Provided that after declaration of a bidder as a successful in Packet 'A' (General Requirements), an application for review may be filed only by a bidder who has participated in procurement proceedings and after declaration of successful bidder in Packet 'B' (Technical Bid), an application for review may be filed only by successful bidders of Packet 'A'. Provided further that, an application for review of the financial bid can be submitted, by the bidder whose technical bid is found to be acceptable / responsive.

Upon receipt of such application for review, B.M.C. may decide whether the bid process is required to be suspended pending disposal of such review. The B.M.C after examining the application and the documents available to him, give such reliefs, as may be considered appropriate and communicate its decision to the Applicant and if required to other bidders or prospective bidders, as the case may be.

B.M.C shall deal and dispose off such application as expeditiously as possible and in any case within 10 days from the date of receipt of such application or such other period as may be specified in pre-qualification document, bidder registration document or bid documents, as the case may be.

Where B.M.C. fails to dispose off the application within the specified period or if the bidder or prospective bidder feels aggrieved by the decision of the procuring entity, such bidder or prospective bidder may file an application for redressal before the 'Internal Procurement Redressal Committee' within 7 days of the expiry of the allowed time or of the date of receipt of the decision, as the case may be. Every such application for internal redressal before Redressal Committee shall be accompanied by fee of Rs.25,000/- fee shall be paid in the form of D.D. in favour of M.C.G.M.

1st Appeal by the bidder against the decision of C.E./HoD/Dean can be made to concerned D.M.C/Director who should decide appeal in 7 days.

If not satisfied, 2nd Appeal by the bidder can be made to concerned A.M.C.for decision .

Grievance Redressal Committee (GRC) is headed by Concerned D.M.C/Director of particular department for the first appeal / Grievances by the bidder against the decision for responsiveness / Non-Responsiveness In Packet 'A',Packet 'B' or Packet 'C' and if not satisfied, Concerned A.M.C.will take decision as per second appeal made by the bidder.

This Grievance Redressal Committee (GRC) will be operated through DMC (CPD) office where appeals of aggrieved bidder will be received with fee of Rs.25000/-from aggrieved bidder.The necessary correspondence in respect of said applications to the aggrieved bidder & concerned department ,issuing notices, arranging of

Grievance Redressal Committee(GRC) with D.M.C.and further proceeding will be carried out through registrar appointed by B.M.C.

No application shall be maintainable before the Redressal Committee in regard of any decision of the B.M.C. relating to following issues:-

- i) Determination of need of procurement
- ii) The decision of whether or not to enter into negotiations.
- iii) Cancellation of a procurement process for certain reasons.

On receipt of recommendation of the Committee, It will be communicate his decision thereon to the Applicant within 10 days or such further time not exceeding 20 days, as may be considered necessary from the date of receipt of the recommendation and in case of non-acceptance of any recommendation, the reason of such non-acceptance shall also be mentioned in such communication.

Additional Municipal Commissioner and/or Grievance Redressal Committee, if found, come to the conclusion that any such complaint or review is of vexatious, frivolous or malicious nature and submitted with the intention of delaying or defeating any procurement or causing loss to the procuring entity or any other bidder, then such complainant shall be punished with fine, which may extend to Five Lac rupees or two percent of the value of the procurement, whichever is higher.

**Full Signature of tenderer
with Official Seal & Address**

ANNEXURE I

**UNDERTAKING FOR PAYING WAGES AS PER MINIMUM WAGES ACT TO
BE SUBMITTED BY TENDERER**

(On Rs.500/- stamp paper)

(To be submitted with packet 'B')

To,

The Commissioner,

Brihanmumbai Municipal Corporation,

Mumbai-400 001.

Subject :	Manufacturing & Supply of refuse collection storage facility and enclosures at various locations in the wards of Mumbai.
E-Tender No	2024_MCGM_

Dear Sir,

I/We, _____(Name of the tenderer) hereby undertake that I/we are paying my/our staff as per Minimum Wages Act-1948, revised by the Government and adapted by BMC from time to time.

For and on behalf of M/s. _____

(Name of Tenderer)

Special Annexure – II

Irrevocable Undertaking

(On Rs.500/- Stamp Paper)

I Shri/Smt.....aged..... Years, Indian Inhabitant. Proprietor/Partner/Directors of M/s.....

resident at do

hereby give Irrevocable Undertaking as under :

1. I say & undertake that as specified in Section 171 of CGST Act, 2017, any reduction in rate of tax on supply of goods or services or the benefit of input tax credit shall be mandatorily passed on to BMC by way of commensurate reduction in prices.
2. I further say and undertake that I understand that in case the same is not passed on and is discovered at any later stage, BMC shall be at liberty to initiate legal action against me for its recovery including, but not limited to, an appeal to the Screening Committee of the GST Counsel.
3. I say that above said irrevocable undertaking is binding upon me/my partners/company/other Directors of the company and also upon my/our legal heirs, assignee, Executor, administrator etc.
4. If I fail to compliance with the provisions of the GST Act, I shall be liable for penalty/punishment or both as per the provisions of GST Act.

Whatever has been stated here in above is true & correct to my/our own knowledge & belief.

Solemnly affirmed at

DEPONANT

This day of

BEFORE ME

Interpreted Explained and Identified by me.

PROFORMAS

Name of the work:- Manufacturing & Supply of refuse collection storage facility and enclosures at various locations in the wards of Mumbai.

PROFORMA - I

The list of similar work stated in PQC during last 7 years

Sr. No.	Name of the Project	Name of the Employer	Stipulated Date of Completion	Actual date of Completion	Actual Cost of Work Done
1	2	3	4	5	6

Note:-

1. Scanned Attested copies of completion/performance certificates from the Engineer-in-Charge for each work should be annexed in the support of information furnished in the above proforma.
2. Works shall be grouped financial year-wise.

PROFORMA – II

Name of the work:- Manufacturing & Supply of refuse collection storage facility and enclosures at various locations in the wards of Mumbai.

PROFORMA – II					
Sr. No.	Financial Year	Actual Turnover of the Works	Updated value to current year	Average of last three years	Page No.
1	2	3	4	5	6

NOTE: The above figures shall tally with the audited balance sheets uploaded by the tenderers duly certified by Chartered Accountant.

PROFORMA III

Name of the work:- Manufacturing & Supply of refuse collection storage facility and enclosures at various locations in the wards of Mumbai.

At least similar works as stated in Para "A" of Post Qualification

Sr. No.	Name of the Project	Name of the Employer	Cost of the Project	Date of issue of Work Order	Stipulated Date of Completion	Actual date of Completion	Remarks explaining reasons for the delay if any
1	2	3	4	5	6	7	8

Note: Scanned Attested copies of completion/performance certificates from the Engineer-in-charge for each work should be annexed in support of information furnished in the above proforma.

PROFORMA IV

Personnel

Sr. No.	Post	Name	Qualification	Work Experience	
		(Prime Candidate/ Alternative)		No. of Years	Name of projects
1	Project manager (10 years experience)				
2	Technical Representative (5 years experience)				
3	Site Engineer (2 years)				
4	Site Supervisor				

Note:- Scanned Attested copies of qualification certificates and details of work experience shall be submitted /uploaded.

PROFORMA - V
Machinery (~~For special works only~~)

Proforma -V/A			
Sr. No.	Equipment	Number	Owned/Leased/ Assured access

Proforma -V/B			
Sr. No.	Equipment	Number	Owned

Note: The tenderer shall furnish/upload the requisite scanned Attested documents of ownership/leased of machineries. The undertaking from the supplier will not be accepted.

PROFORMA – VI

Name of the work:- Manufacturing & Supply of refuse collection storage facility and enclosures at various locations in the wards of Mumbai.

PROFORMA – VI A

Details of existing commitments & Ongoing Works

Place	Contract no. & date	Name & Address of the employer	Value of the contract in Rs.	Scheduled date of completion	Value of remaining work to be completed	Anticipated date of completion

PROFORMA – VI B

Details of work for which bids are already uploaded

Description of work	Place	Name & Address of the employer	Value of the contract in Rs.	Time Period	Date on which decision is expected	Remarks

Note:- Scanned Attested copies of certificates from the Engineer-in-charge for each work shall be annexed.

Supply of Refuse Compactor Container for Collection of Garbage

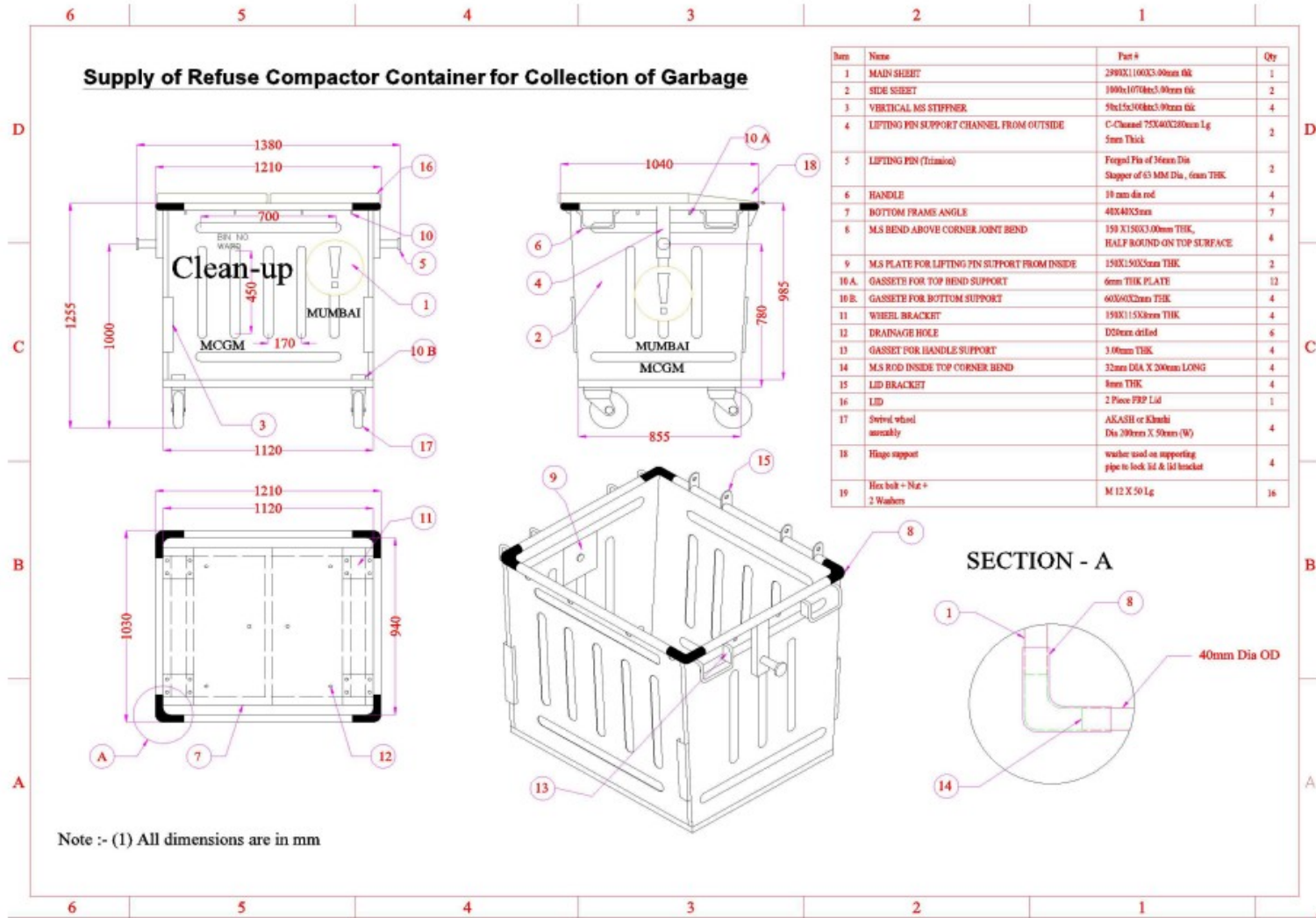

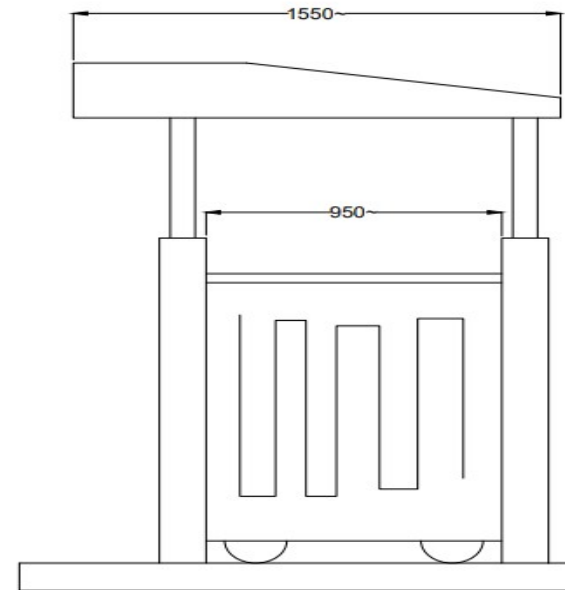
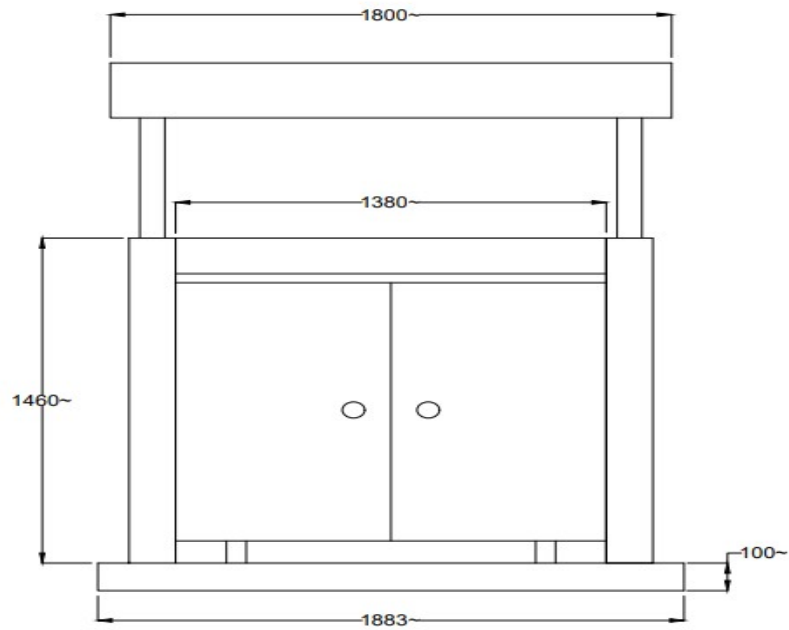

Note :- (1) All dimensions are in mm