

**BRIHANMUMBAI MUNICIPAL CORPORATION**

**E-TENDER FOR**

**BID NO: 7200052322**

**Subject: Maintenance of ANPR Cameras with associated accessories of Speed Violation Detection System in Brihanmumbai for the period of two years (01.09.2023 to 31.08.2025).**

---

Website: <https://portal.mcgm.gov.in>  
Office of: Chief Engineer (Roads & Traffic),  
Engineering Hub Building,  
Dr. E.Moses Road,  
Worli Naka, Worli,  
Mumbai- 400 018. INDIA

# INDEX

<b>SECTION</b>	<b>DESCRIPTION</b>	<b>PG-NO</b>
<b>1</b>	<b>E-TENDER NOTICE</b>	<b>3-6</b>
<b>2</b>	<b>ELIGIBILITY CRITERIA</b>	<b>7-8</b>
<b>3</b>	<b>DISCLAIMER</b>	<b>9-11</b>
<b>4</b>	<b>INTRODUCTION</b>	<b>12-13</b>
<b>5</b>	<b>E-TENDER ONLINE SUBMISSION PROCESS</b>	<b>14-16</b>
<b>6</b>	<b>INSTRUCTIONS TO BIDDERS</b>	<b>17-34</b>
<b>7</b>	<b>SCOPE OF WORK</b>	<b>35-38</b>
<b>8</b>	<b>BILL OF QUANTITIES</b>	<b>39-43</b>
<b>9</b>	<b>GENERAL CONDITIONS OF CONTRACT</b>	<b>44-45</b>
<b>10</b>	<b>SPECIFICATIONS &amp; SELECTION OF MATERIAL</b>	<b>46-55</b>
<b>11</b>	<b>FRAUD AND CORRUPT PRACTICES</b>	<b>56-59</b>
<b>12</b>	<b>LIST OF APPROVED BANKS</b>	<b>50-63</b>
<b>13</b>	<b>SPECIAL INSTRUCTIONS TO BIDDERS</b>	<b>64-69</b>
<b>14</b>	<b>APPENDIX &amp; PROFORMAS</b>	<b>70-104</b>
<b>15</b>	<b>LIST OF LOCATION OF SPEED VIOLATION SYSTEM</b>	<b>105-106</b>

# **SECTION 1**

## **E-TENDER NOTICE**

# BRIHANMUMBAI MUNICIPAL CORPORATION

Department: Chief Engineer (Roads & Traffic)

No. Dy.Ch.E/ATC-281/ Traffic dated 09.05.2023

## e-TENDER NOTICE

### E- Tender no: 7200052322

**Subject: Maintenance of ANPR Cameras with associated accessories of Speed Violation Detection System in Brihanmumbai for the period of two years (01.09.2023 to 31.08.2025).**

The Brihanmumbai Municipal Corporation (BMC) invites e-tender on percentage Basis for subject work from contractors of repute, multidisciplinary engineering organizations i.e. eminent firm, Proprietary/Partnership Firms/ Private Limited Companies/ Public Limited Companies/Companies registered under the Indian companies' act 2013, the contractors registered with the Brihanmumbai Municipal Corporation, (BMC) in **Class AA as per old or Class A as per new registration** in Electrical/ Mechanical/ Electronics and from the contractors/firms equivalent and superior classes registered in Central or State Government/Semi Govt. Organization/Central or State Public Sector Undertakings, will be allowed subject to condition that, the contractors who are not registered with BMC will have to apply for registering their firm within three months time period from the award of contract, otherwise their Bid Security i.e. E.M.D (Earnest Money Deposit) will be forfeited/recovered and an amount equal to Registration Fee of respective class will be recovered as penalty.

Bidding Process will comprise of THREE stages.

The Bid can be downloaded from BMC's portal (<https://portal.mcgm.gov.in>) and on payment of Rs. 11,500/- + Applicable GST. The bidders not registered with BMC are mandated to get registered (Vendor Registration) with BMC for e-tendering process & obtain login credentials to participate in the online bidding process.

- i) To download the application form, for those applicants not having vendor registration, need to apply first for vendor registration at the office of Central Purchase Department (CPD), Office at Byculla, Bakariadda, Mumbai.
- ii) Followed by SRM login ID and password to be obtained from Central Purchase Department (CPD), Office at Byculla, Bakariadda, Mumbai
- iii) For e-Tendering registration, enrolment for digital signature certificates and user manual, please refer to respective links provided in 'Tenders' tab. Vendors can get digital signature from any one of the Certifying Authorities (CA's) licensed by controller of certifying authorities namely, Safes crypt, IDRBT, National informatics centre, TCS, CUSTOMS, MTNL, GNFC and e-Mudhra CA.

Sr No	Name of the work	Contract Period	Estimated Cost of project (Rs)
1	Maintenance of ANPR Cameras with associated accessories of Speed Violation Detection System in Brihanmumbai for the period of two years (01.09.2023 to 31.08.2025).	24 months	Rs. 1,30,02,826/-

In terms of the 3 stage system of e-tendering, Bidder will be required to deposit, along with its Bid, an Earnest Money Deposit (EMD) of Rs.1,30,100/- (Rupees One Lakh Thirty Thousand One Hundred only), refundable in accordance to the relevant clause of bid document, from the Bid Due Date, except in the case of the selected Bidder whose Bid Security/EMD shall be retained. The Bidders will have to provide Earnest Money Deposit through the payment gateways while submitting the bids. The Bid shall be summarily rejected if it is not accompanied by the Earnest Money Deposit. The e-tender is available on BMC portal (<https://portal.mcgm.gov.in>) as mentioned in the Header Data of Tender.

As per THREE Packet systems, the document for Packet A & B is to be uploaded by the bidder in vendors' document online in Packet A, B. Packet A, B & C shall be opened on dates as mentioned in header data. All the responsive and eligible bidders if they so wish can be present at the time of opening of bids, in the office of Ex. Engineer (ATC). The Packet C shall be opened if bids submission in Packet A & B satisfies/includes all the requirements and same are found acceptable to the Authority.

The Municipal Commissioner reserves the right to reject all or any of the e-tender(s) without assigning any reasons at any stage.

The dates and time for submission and opening the bids are as shown in the Header Data. If there are any changes in the dates, the same will be displayed on the BMC Portal. (<https://portal.mcgm.gov.in>)

The interested bidders for the subject work may contact the Ex. Engr. (Area Traffic Control) at the following address on any working day during office hours.

Office of: Executive Engineer (Area Traffic Control),  
Ground Floor, Engineering Hub Building,  
Dr.E.Moses Road, Worli, Mumbai- 400 018,

The bidders may wish to visit the site for the subject work and can collect the information of the present status from the department who have invited the bids.

The BMC reserves the rights to accept any of the bid or reject any or all the bids received for subject work, without assigning any reasons thereof. The information regarding above subject matter is available on Website of BMC. (<https://portal.mcgm.gov.in>)

**Sd/-(09.05.2023)**  
**Dy. Ch. Engineer (Traffic)**

## **HEADER DATA**

<b>Tender Document Number</b>	7200052322
<b>Name of Organization</b>	Brihanmumbai Municipal Corporation
<b>Subject</b>	<b>Maintenance of ANPR Cameras with associated accessories of Speed Violation Detection System in Brihanmumbai for the period of two years (01.09.2023 to 31.08.2025)</b>
<b>Cost of Tender</b>	Rs. 11,500/- + Applicable GST
<b>Cost of E-Tender(Estimated Cost)</b>	Rs. 1,30,02,826/-
<b>Bid Security Deposit/ EMD</b>	Rs. 1,30,100/-
<b>Date of issue and sale of tender</b>	11.05.2023 from 11:00 Hrs
<b>Last date &amp; time for sale of tender</b>	05.06.2023 upto 12:00 Hrs
<b>Submission of Packet A, B &amp; Packet C(Online) &amp; (Receipt of Bid Security Deposit)</b>	05.06.2023 upto 16:00 Hrs
<b>Opening of Packet A</b>	06.06.2023 after 15:00 Hrs
<b>Opening of Packet B</b>	06.06.2023 after 15:10 Hrs
<b>Opening of Packet C</b>	15.06.2023 after 15:00 Hrs
<b>Address for communication</b>	Office of Ex. Engr. (Area Traffic Control), Ground Floor, Engineering Hub, Dr. E.Moses Road, Worli, Mumbai- 400 018
<b>Venue for opening of bid</b>	On line in the office of Ex. Engr (Area Traffic Control).
<b>Mail id for any issue in online e-tendering process</b>	<a href="mailto:etendering.it@mcgm.gov.in">etendering.it@mcgm.gov.in</a> .

**This tender document is not transferable.**

The BMC reserves the rights to accept any of the bid or reject any or all the bid received for above subject without assigning any reason thereof.

**Sd/- (09.05.2023)**  
**Dy. Ch. Engineer (Traffic)**

# **SECTION 2**

## **ELIGIBILITY CRITERIA**

Name of the Dept	Details of work
Roads & Traffic	Maintenance of ANPR Cameras with associated accessories of Speed Violation Detection System in Brihanmumbai for the period of two years (01.09.2023 to 31.08.2025)

**2 .1 Technical Capacity:**

The tenderer(s) in their own name shall have satisfactorily executed the work of similar nature in BMC /Semi Govt. /Govt. & Public Sector Organizations etc. during **last seven (7) years** ending last day of month previous to the one in which bids are invited as a prime Contractor.

I. **Three similar completed works each** of value not less than the value equal to **20%** of estimated cost put to tender.

Or

II. **Two similar completed works each** of value not less than the value equal to **25%** of estimated cost put to tender.

Or

III. **One similar completed work** of value equal and or not less than the **40%** of estimated cost put to tender

The value of executed works shall be brought to current costing level by enhancing the actual value of work at compounded rate of 10 % per annum; calculated from the date of completion to the last date of receipt of bids for tenders.

**2.2 Financial Capacity:**

Achieved an average annual financial turnover as certified by 'Chartered Accountant' equal to **30%** of the estimated cost of work in **last three (3) financial years** immediately preceding the Financial Year in which bids are invited. i.e. 2019-20,2020-21,2021-22.

**2.3 Similar Experience:**

"Supply, installation, & commissioning of Speed Violation Detection System in Mumbai or any of the Urban City".

OR

"Maintenance of Speed Violation Detection System in Mumbai or any of the Urban City".

# **SECTION 3**

## **DISCLAIMER**

## **DISCLAIMER**

The information contained in this e-tender document or provided to bidder(s), whether verbally or in documentary or any other form, by or on behalf of the Brihanmumbai Municipal Corporation (BMC), hereafter also referred as "The Authority", or any of its employees or advisors, is provided to bidder(s) on the terms and conditions set out in this e-tender and such other terms and conditions subject to which such information is provided.

This e-tender includes statements, which reflect various assumptions and assessments arrived at by the Brihanmumbai Municipal Corporation (BMC) in relation to the Project. Such assumptions, assessments and statements do not purport to contain all the information that each bidder may require. This e-tender may not be appropriate for all persons, and it is not possible for the Brihanmumbai Municipal Corporation (BMC), its employees or advisors to consider the investment objectives, financial situation and particular needs of each party who reads or uses this e-tender. The assumptions, assessments, statements and information contained in this e-tender may not be complete, accurate, adequate or correct. Each bidder should therefore, conduct its own investigations and analysis and should check the accuracy, adequacy, correctness, reliability and completeness of the assumptions, assessments, statements and information contained in this e-tender and obtain independent advice from appropriate sources.

Information provided in this e-tender to the bidder(s) is on a wide range of matters, some of which may depend upon interpretation of law. The information given is not intended to be an exhaustive account of statutory requirements and should not be regarded as a complete or authoritative statement of law. The Brihanmumbai Municipal Corporation (BMC) accepts no responsibility for the accuracy or otherwise for any interpretation or opinion on law expressed here.

The Brihanmumbai Municipal Corporation (BMC), its employees and advisors make no representation or warranty and shall have no liability to any person, including any Bidder, under any law, statute, rules or regulations or tort, principles of restitution or unjust enrichment or otherwise for any loss, damages, cost or expense which may arise from or be incurred or suffered on account of anything contained in this e-tender or otherwise, including the accuracy, adequacy, correctness, completeness or reliability of the e-tender and any assessment, assumption, statement or information contained therein or deemed to form part of this e-tender or arising in any way with pre-qualification of bidders for participation in the Bidding Process. The Brihanmumbai Municipal Corporation (BMC) also accepts no liability of any nature whether resulting from negligence or otherwise howsoever caused arising from reliance of any bidder upon the statements contained in this e-tender.

The Brihanmumbai Municipal Corporation (BMC) may, in its absolute discretion but without being under any obligation to do so, update, amend or supplement the information, assessment or assumptions contained in this e-tender.

The issue of this e-tender does not imply that the Brihanmumbai Municipal Corporation (BMC) is bound to select and short-list pre-qualified Applications for Bid Stage or to appoint the selected Bidder or Concessionaire, as the case may be, for the Project and the Brihanmumbai Municipal Corporation (BMC) reserves the right to reject all or any of the Applications or Bids without assigning any reasons whatsoever.

The bidder shall bear all its costs associated with or relating to the preparation and submission of its bid including but not limited to preparation, copying, postage,

delivery fees, expenses associated with any demonstrations or presentations which may be required by The Brihanmumbai Municipal Corporation (BMC) or any other costs incurred in connection with or relating to its bid. All such costs and expenses will remain with the bidder and the Brihanmumbai Municipal Corporation (BMC) shall not be liable in any manner whatsoever for the same or for any other costs or other expenses incurred by bidder in preparation or submission of the bid, regardless of the conduct or outcome of the Bidding Process.

# **SECTION 4**

## **INTRODUCTION**

## **INTRODUCTION**

### **4 .1 Background:**

The Brihanmumbai Municipal Corporation covers an area of 483.14 sq.kms. with a population of 1.24 Crores as per census of 2011. The metropolis accounts major portion of India's international trade and government's revenue, from being one of the foremost centers of education, science and technological research and advancement. The Mumbai Metropolis has historic tradition of strong civic activism dedicated to the cause of a better life for all its citizens. And it's the Brihanmumbai Municipal Corporation (BMC), hereafter called the "corporation", the primary agency responsible for urban governance in Brihanmumbai.

BMC (The Authority) is one of the largest local self-governments in the Asian Continent. In observance of historic traditions of strong civic activism, with the change in time and living conditions to match with the urbanization, BMC has mainly focused in providing almost all kinds of engineering services viz, Hydraulics, storm water drain, sewerage, water supply projects, roads, bridges, solid waste management, and environmental services. Beside this, the BMC is also providing dedicated services in various segments such as Health, Primary Education as well as the construction and maintenance of Public Markets and Slaughter Houses.

BMC is an organization having different departments, right from engineering depts. to health depts. Moreover there are other dept. like education, market, fire brigade dept., Octroi and other such departments where quite a good number of staff members are working.

The ATC section under the Deputy Chief Engineer (Traffic) of BMC is handling the maintenance of Traffic Signal Junctions. This section is maintaining the Speed Violation Detection System. Speed Violation Detection System was introduced for ITS by considering the number of accidental deaths on highways causing by over speeding of vehicles. Automatic Number Plate Recognition (ANPR) is a technology for automatically reading vehicle number plates. Speed Limit violation detection system is working as a Detection System for those vehicles which crosses the maximum allowed speed limit on that particular route and the vehicle owners are penalized through e-Challan system of Traffic Police. This system will be capturing the Speed of each vehicle along with number plate through an Image for those vehicles which crosses the desired speed limit on that route.

At present 52 nos of ANPR Cameras are installed at various locations in Brihanmumbai for Speed Violation Detection System and 12 nos of ANPR camera will be installed at newly constructed flyover spanning at Ghatkopar Mankhurd Link Road in M/E ward of Brihanmumbai. The technical details of existing system are attached separately under Section 10 of this tender document. Under the present proposal, it is proposed to maintenance of 52 nos of existing ANPR Cameras and 12 nos of upcoming ANPR cameras & other allied equipment of Speed Violation Detection System. The scope of the work under present proposal is attached separately under the section 7 of this tender Document.

# **SECTION 5**

## **E-TENDERING ONLINE SUBMISSION PROCESS**

# E-TENDERING ONLINE SUBMISSION PROCESS

The terminology of e-Tendering is solely depending upon policies in existence, guidelines and methodology adopted since decades. The SRM is only change in process of accepting and evaluation of tenders in addition to manual. The SAP module to be used in this E-tendering is known as Supplier Relationship Module (SRM). SRM is designed and introduced by ABM Knowledge ware Ltd. who will assist BMC in throughout the tendering process for successful implementation.

**NOTE:** This tendering process is covered under Information Technology ACT & Cyber Laws as applicable

(1) In e-tendering process some of the terms and its definitions are to be read as under wherever it reflects in online tendering process.

Start Date read as "Sale Date"

End Date read as "Submission Date"

Supplier read as "Contractor/bidder"

Vendor read as "Contractor/bidder"

Vendor Quotation read as "Contractors Bid/Offer"

Purchaser read as "Department/MCGM"

I. Before entering in to online tendering process, the contractors should complete the registration process so as to get User ID for E-tendering links. For this, the contractors can access through Supplier registration via BMC Portal.

There are two methods for this registration:(II and III)

II. Transfer from R3 (registered contractors with BMC) to SRM

a. Contractors already registered with BMC will approach to Vendor Transfer cell.

b. Submit his details such as (name, vendor code, address, registered Email ID, pan card etc.) to Vendor transfer cell.

c. BMC authority for Vendor Transfer, transfers the Vendor to SRM application from R3 system to SRM system.

d. Transferred Vendor receives User ID creation link on his supplied mail Id.

e. Vendor creates his User ID and Password for e-tendering applications by accessing link sent to his mail ID.

III. Online Self Registration (Temporary registration for bidder not registered with BMC)

a. Vendor fills up Self Registration form via accessing BMC portal.

b. Vendor Transfer cell (same as mentioned above) accesses Supplier Registration system and accepts the Vendor request.

c. Accepted Vendor receives User ID creation email with Link on his supplied mail Id.

d. Vendor creates his User ID and Password for e-tendering application.

IV. CONTRACTORS BIDDING:

For E-Tendering online submission process, please refer the manual available on BMC portal <http://portal.mcgm.gov.in> and same can be downloaded from the below link:  
<https://portal.mcgm.gov.in/irj/go/km/docs/documents/HomePage%20Data/Whats%20New/220721.pdf>

The tenderer shall pay the EMD/Bid Security through payment gateways before submission of Bid and shall upload the screenshot of receipt of payment in Packet 'A' instead of paying the EMD at any of the CFC centers in BMC Ward Offices.

The e-tender is available on BMC portal, <https://portal.mcgm.gov.in>, as mentioned in the Header Data of the tender. The tenders duly filled in should be uploaded and submitted online on or before the end date of submission. The Packet 'A', Packet 'B' & Packet 'C' of the tender will be opened as per the time-table shown in the Header Data in the office of Ex. Engineer (ATC).

The Municipal Commissioner reserves the right to reject all or any of the e-Tenders(s) without assigning any reason at any stage. The dates and time for submission and opening the tenders are as shown in the Header Data. If there are any changes in the dates the same will be displayed on the BMC Portal (<https://portal.mcgm.gov.in>).

In case of any issue related to e-tendering online process, please mail to [etendering.it@mcgm.gov.in](mailto:etendering.it@mcgm.gov.in). with error screenshot.

# **SECTION 6**

## **INSTRUCTIONS TO BIDDERS**

## INSTRUCTIONS TO BIDDERS

### 6.1 Scope of Bid:

The BMC Authority wishes to receive bids for Qualification in order to SELECT experienced and capable bidder for the work of **"Maintenance of ANPR Cameras with associated accessories of Speed Violation Detection System in Brihanmumbai for the period of two years (01.09.2023 to 31.08.2025)"**

### 6.2 Eligibility of Bidders:

The Brihanmumbai Municipal Corporation (BMC) invites e-tender on Percentage Basis to appoint Contractor for the work of "Maintenance of ANPR Cameras with associated accessories of Speed Violation Detection System in Brihanmumbai for the period of two years (01.09.2023 to 31.08.2025)." from contractors of repute, multidisciplinary engineering organizations i.e. eminent firm, Proprietary/Partnership Firms/ Private Limited Companies/ Public Limited Companies/Companies registered under the Indian companies' act 2013, the contractors registered with the Brihanmumbai Municipal Corporation, (BMC) in **Class AA as per old registration or Class A as per new registration** in Electrical/ Mechanical/ Electronics and from the contractors/firms equivalent and superior classes registered in Central or State Government/Semi Govt. Organization/Central or State Public Sector Undertakings, will be allowed subject to condition that, the contractors who are not registered with BMC will have to apply for registering their firm within three months time period from the award of contract, otherwise their Bid Security i.e. E.M.D (Earnest Money Deposit) will be forfeited/recovered and an amount equal to Registration Fee of respective class will be recovered as penalty.

To be eligible for pre-qualification and short-listing, the bidder shall fulfil the following conditions of eligibility:

### 6.3 For Regular, Routine and Maintenance works:

Name of the Department	Details of project works
<b>Roads &amp; Traffic</b>	<b>Maintenance of ANPR Cameras with associated accessories of Speed Violation Detection System in Brihanmumbai for the period of two years (01.09.2023 to 31.08.2025)</b>

### 6.4 Technical Capacity:

The tenderer(s) in their own name shall have satisfactorily executed the work of similar nature in BMC /Semi Govt. /Govt. & Public Sector Organizations etc. during **last seven (7) years** ending last day of month previous to the one in which bids are invited as a prime Contractor.

- I. **Three similar completed** works **each** of value not less than the value equal to **20%** of estimated cost put to tender.

Or

II. **Two similar completed works each** of value not less than the value equal to **25%** of estimated cost put to tender.

Or

III. **One similar completed work** of value equal and or not less than the **40%** of estimated cost put to tender

The value of executed works shall be brought to current costing level by enhancing the actual value of work at compounded rate of 10 % per annum; calculated from the date of completion to the last date of receipt of bids for tenders.

#### **6.5 Financial Capacity:**

Achieved an average annual financial turnover as certified by 'Chartered Accountant' equal to **30%** of the estimated cost of work in **last three (3) financial years** immediately preceding the Financial Year in which bids are invited. i.e. 2019-20, 2020-21, 2021-22.

#### **6.6 Similar Experience:**

"Supply, installation, & commissioning of Speed Violation Detection System in Mumbai or any of the Urban City".

OR

"Maintenance of Speed Violation Detection System in Mumbai or any of the Urban City".

#### **6.7 Bid Capacity:**

The bid capacity of the prospective bidders will be calculated as under:

**Assessed Available Bid Capacity = (A\* N\* 2 – B)**

Where,

**A**= Maximum value of Mechanical /Electrical/Electronics/Information Technology/ Computer Engineering works executed in any one year (year means Financial year) during **the last five years** (updated to the price level of the Financial year in which bids are received at a rate of 10% per year) taking into account the completed as well as works in progress.

**N** = Number of years prescribed for completion of the Project/Works, **excluding monsoon period**, for which these bids are being invited. (E.g. 7 months = 7/12 year) For every intervening monsoon 0.33 shall be added to N.

**B** = Value of existing commitments (only allotted works) on the last date of submission of bids as per bidding document and on-going works to be completed during the period of completion of the Project/Works for which these bids are being invited.

**Note:** The statement showing the value of existing commitments and on-going works as well as the stipulated period of completion remaining for each of the works listed should be attached along with certificates duly signed by the Engineer-in Charge, not below the rank of an Executive Engineer or equivalent.

**Even though the bidders meet the above qualifying criteria, they are subject to be disqualified if they have:**

- made misleading or false representation in the forms, statements and attachments submitted in proof of the qualification requirements; and/or

- Record for poor performance such as abandoning the works, not properly completing the contract, inordinate delays in completion or financial failures etc.

### 6.8 Equipment Capabilities:

The successful bidder will make an arrangements of the required equipment on the day of commencement or with respect to the progress of the work in phases, as per the instructions of site in charge. The successful bidder to that effect will ensure commitment on an undertaking on Rs.500/- stamp paper to be submitted along with the Bid in Packet B.

### 6.9 Technical Personnel:

Bidder and/or its managerial staff should have qualification/experience appropriate to the function they fulfil. The minimum standard shall be increased by asking that at least one number or more of the bidder or its managerial staff have acquired qualification or work experience to the need of the contract. The minimum standard may also state that the person or persons responsible for managing the works must have a minimum numbers of years experience working on similar nature of projects.

Bidder(s) shall supply general information on the management structure of the firm, and shall have provisions of suitably qualified personnel to fill the key positions as required during the contract implementation.

The Bidder(s) shall supply information on a prime candidate or an alternate for each key position and each shall meet the requirements specified as under:

Sr · N o.	Personnel	Qualification	Experience	No. of staff to be de- ployed	Rate of Re- covery in case of non-compli- ance
1	Principal Technical Representat ive	Graduate Engineer or Diploma Engineer	Minimum Two years experience for Graduate Engineer and Minimum Five years experience for Diploma Engineer.	1	Rs. 25,000/- per month
2	Field Representat ive	ITI in Electrical /Electronics or PWD License in Electrical.	Minimum two years experience in the relevant field	1	15,000/- per month

1. The labours shall be provided for handling (loading/unloading) of various materials/ labourer work as applicable in damage work as & when required at site.

2. It is sole responsibility of the contractor to provide requisite staff required for execution of work. The Transportation facility equipped with all necessary equipment / tools & tackle etc. shall be provided
3. The tenderer shall furnish general information on the organizational set up of the firm.
4. The Principal Technical Representative shall be empowered for financial, administrative, technical etc. decisions.
5. Duration of the Contract:- 24 months (Inclusive of monsoon).

#### **6.10 Time period of the contract:**

Time period of the work is 24 months inclusive of Monsoon.

#### **6.11 Contract Execution:**

All required documents for execution of the contract shall be submitted within 30 days from the date of issue of letter of acceptance. If the documents are not submitted within the stipulated time, a penalty of Rs 5000/- per day will be applicable to the contractor. The contract documents need to be duly affixed with stamp duty properly signed along with evidence/proof of payment of security/contract deposit/ within 30 days from the date of letter of acceptance received by him.

**6.12** If the amount of Contract Deposit is not paid within 30 Days from the date of issue of Letter of Acceptance, the tenderer/contractor already accepted shall be considered as cancelled and legal steps shall be taken against the contractor for recovery of amounts.

**6.13** The amount of Contract Deposit retained by the BMC shall be released after expiry of contract period up to which the contractor has agreed to maintain the work in good order is over. In the event of the contractor failing or neglecting to complete the rectification work within the period up to which the contractor has agreed to maintain the work in good order, the amount of security deposit retained by BMC shall be adjusted towards the excess cost incurred by the Department on rectification work.

#### **6.14 Action when whole of security deposit is forfeited:**

In any case in which under any Clause of this contract, the contractor shall have rendered himself liable to pay compensation amounting to the whole of this security deposit whether paid in one sum or deducted by installments or in the case of abandonment of the work owing to serious illness or death of the contractor or any other cause, the Engineer on behalf of the Municipal Commissioner shall have power to adopt any of the following process, as he may deem best suited to the interest of BMC -

- (a) To rescind the contract (for which rescission notice in writing to the contractor under the head of Executive Engineer shall be conclusive evidence) and in that case, the security deposit of the contract shall stand forfeited and be absolutely at the disposal of BMC.

- (b) To carry out the work or any part of the work departmentally debiting the contractor with the cost of the work, expenditure incurred on tools and plant, and charges on additional supervisory staff including the cost of work-charged establishment employed for getting the un-executed part of the work completed and crediting him with the value of the work done departmentally in all respects in the same manner and at the same rates as if it had been carried out the work-by the contractor under the terms of his contract. The certificate of the Executive Engineer as to the costs and other allied expenses so incurred and as to the value of the work so done departmentally shall be final and conclusive against the contractor.
- (c) To order that the work of the contractor be measured up and to take such part thereof as shall be un-executed out of his hands, and to give it to another contractor to complete, in which case all expenses incurred on advertisement for fixing a new contracting agency, additional supervisory staff including the cost of work charged establishment and the cost of the work executed by the new contract agency will be debited to the contractor and the value of the work done or executed through the new contractor shall be credited to the contractor in all respects and in the same manner and at the same rates as if it had been carried out by the contractor under the terms of his contract. The certificate of the Executive Engineer as to all the cost of the work and other expenses incurred as aforesaid for or in getting the un-executed work done by the new contractor and as to the value of the work so done shall be final and conclusive against the contractor.

In case the contract shall be rescinded under Clause (a) above, the contractor shall not be entitled to recover or be paid any sum for any work therefore actually performed by him under this contract unless and until the Executive Engineer shall have certified in writing the performance of such work and the amount payable to him in respect thereof and he shall only be entitled to be paid the amount so certified. In the event of either of the courses referred to in Clause (b) or (c) being adopted and the cost of the work executed departmentally or through a new contractor and other allied expenses exceeding the value of such work credited to the contractors amount of excess shall be deducted from any money due to the contractor, by BMC under the contract or otherwise, howsoever, or from his security deposit or the sale proceeds thereof provided, however, the contractor shall have no claim against BMC even if the certified value of the work done departmentally or through a new contractor exceeds the certified cost of such work and allied expenses, provided always that whichever of the three courses mentioned in clauses (a), (b) or (c) is adopted by the Executive Engineer, the contractor shall have no claim to compensation for any loss sustained by him by reason of his having purchase or procured any materials or entered in to any engagements or made any advance on account of or with a view to the execution of the work or the performance of the contract.

#### **6.15 Contract may be rescinded and security deposit forfeited for bribing a public officer or if contractor becomes insolvent**

If the contractor assigns or sublets his contracts or attempt so to do, or become insolvent or commence any proceeding to get himself adjudicated and insolvent or make any composition with his creditors, or attempt so to do or if bribe, gratuity, gift,

loan, perquisite, reward or advantage, pecuniary or otherwise, shall either directly or indirectly be given promised or offered by the contractor or any of his servants or agents through any public officer, or person in the employ of BMC/Govt. in any way relating to his office or employment, or if any such officer or person shall become in any way directly or indirectly interested in the contract the Engineer In-charge may thereupon, by notice in writing rescind the contract and the Security Deposit of the Contractor shall thereupon stand forfeited and be absolutely at the disposal of BMC and the same consequences shall ensue as if the contract had been rescinded under applicable clause; and in addition the contractor shall not be entitled to recover or be paid for any work therefore actually performed under the contract.

## 6.16 Submission of Tenders

### PACKET – A

The Packet 'A' shall contain scanned certified copies of the following documents. Scrutiny of this packet will be done strictly with reference to only the scanned copies of Documents uploaded online in packet 'A'

- a) Valid Registration Certificate.
- b) Valid Bank Solvency Certificate of minimum solvency amount as governed by Registration Rules in force for respective Class of Contractor for M & E Works, issued not more than Six months prior to the date of submission of tender and valid upto one year.
- c) A document in support of Registration under Goods & Service Tax (GST) Act 2017.
- d) Certified copies of valid 'PAN' documents and photographs of the individuals, owners, Karta of Hindu undivided Family, firms, private limited companies, registered co-operative societies, partners of partnership firms and at least two Directors, if number of Directors are more than two in case of Private Limited Companies, as the case may be. However, in case of Public Limited companies, Semi Government Undertakings, Government Undertakings, no 'PAN' documents will be insisted.
- e) Latest Partnership Deed in case of Partnership firm duly registered with Chief Accountant (Treasury) of BMC.
- f) Valid Email-ID of bidder/firm.
- g) Screenshot of EMD payment receipt.

#### NOTE:

- If the tenderer(s) withdraw tender offer during the tender validity period, his entire E.M.D shall be forfeited.
- If it is found that the tenderer has not submitted required documents in Packet "A" then, the shortfalls will be communicated to the tenderer through e-mail only and compliance required to be made within a time period of **three working days** otherwise they will be treated as non-responsive and 10% of EMD will be forfeited.

### PACKET – B

The Packet 'B' shall contain scanned certified copies of the following documents –

- a) Annexure A
- b) The undertaking of Rs. 500/- stamp paper as per the proforma annexed in Annexure B: - Pre-Contract Integrity Pact & Annexure C: - Declaration Cum Indemnity

## Bond

- c) The list of similar type of works as stated in Eligibility Criteria in prescribed proforma - I, in the role of prime contractor. Information furnished in the prescribed proforma (Proforma - I) shall be supported by the certificate duly self-attested. Documents stating that it has successfully executed during the last seven years at least one contract of similar works as stated in Eligibility Criteria.
- d) Annual financial turnover for preceding three financial years as certified by Chartered Accountant preceding the Financial Year in which bids are invited. Copies of Documents of audited balance sheet and profit and loss account for the preceding five financial years in which bids are invited. (Proforma - II).
- e) Details of similar works as stated in Eligibility Criteria (Proforma - III).
- f) Documents stating that, it has access to or has available liquid assets, unencumbered assets, lines of credit and other financial means (independent of any contractual advance payment) sufficient to meet the cash flow requirements for the subject contract in the event of stoppage, start-up, or other delay in payment, of the minimum 15% of the cost of the work tendered for, net of the tenderer's commitment of other contracts (Certificate from Bankers / C.A./Financial Institution shall be accepted as an evidence).
- g) Details of Personnel (Proforma - IV)
- h) Details of works in hand (Proforma VI-A & VI-B), along with copies of work orders & attested copies of percentage of works completed or part thereof.
- i) Affidavit for BEST Price (Proforma VII)
- j) Copy of Structure & Organisation (Proforma VIII)
- k) Copy of Litigation History (Proforma-IX)
- l) Declaration from the bidder for Supply of Truck mounted Aerial /Boom Lift Crane (Proforma - X)
- m) The successful bidder shall submit valid registration certificate under E.S.I.C., Act 1948, if the tenderer has more than 10 employees /persons on his establishment (in case of production by use of energy) and 20 employees/persons on his establishment (in case of production without use of energy) to BMC as and when demanded. In case of less employees/persons mentioned above then the successful bidder has to submit an undertaking to that effect on Rs. 200/- stamp paper as per circular u/no. CA/FRD/I/65 of 30.03.2013.
- n) The successful bidder shall submit valid registration certificate under E.P.F. & M.P., Act 1952, if tenderer has more than 20 employees/persons on his establishment, to BMC as and when demanded. In case if the successful bidder has less employees/persons mentioned above then the successful bidder has to submit an undertaking to that effect on Rs. 200/- stamp paper as per circular u/no. CA/FRD/I/44 of 04.01.2013.
- o) Signed copy of the Addendum if any.
- p) Form of Tender (As prescribed in Tender Document) duly filled in & digitally signed.
- q) Statement showing assessed available Bid Capacity.
- r) Irrevocable Undertaking on Rs. 500/- Stamp paper as per Annexure -E
- s) Annexure F; Technical Data sheet.

## Note:

If it is found that the tenderer has not submitted required documents in Packet "B" then, the shortfalls will be communicated to the tenderer through e-mail only and

compliance required to be made within a time period of **three working days** otherwise they will be treated as **non-responsive** and 10% of EMD will be forfeited.

### **PACKET – C**

Online tender filled in either percentage plus or minus (above or below), or at par. (There is no separate provision to quote & in physical form, this is a part in Header Data of online Tendering). For Packet 'C' tenderer(s) will fill data in 'Item Data Tab' in Service Line Item via Details and quotes his percentage variation figures. (If entered '0' it will be treated as 'at par'. By default the value is zero only).

#### **Note:**

- 1. Bidder Shall quote inclusive of all taxes other than GST (exclusive GST), levies, duties, cess etc as applicable.**
- 2. In case of rebate/premium of 15% and above as quoted by the tenderer, the rate analysis of major items shall be submitted by L1 and L2 bidder after demand notification by e-mail to bidders by Ex. Eng. (ATC). The format for rate analysis is annexed at Annexure D.**

#### **6.17 Bid Security or Earnest Money Deposit (EMD)**

- The Bidder shall furnish, as part of the Bid, EMD, in the amount specified in the Header Data Sheet. This bid security shall be in favour of the authority mentioned in the Bid Data Sheet and shall be valid till the validity of the bid.
- The tenderers shall pay the EMD online.
- Any bid not accompanied by an acceptable Bid Security and not secured as indicated in sub-clause mentioned above, shall be rejected by the Employer as non-responsive.
- The Bid Security/EMD of the successful Bidder will be discharged when the Bidder has signed the Agreement and furnished the required Security Deposits.
- The EMD and ASD of L-2 and other higher bidders (L-3, L-4, etc.) shall be refunded immediately after opening of financial bid. In case, the successful bidder becomes non-responsive or successful bidder withdraws the bid or is unwilling to extend the bid validity period, in such circumstances, if L-2 bidder is agreeable to extend the bid validity period and ready to deposit the requisite amount of EMD and ASD to the department within the stipulated time period i.e. 15 days, the department will process further as per normal procedure.

The EMD may be forfeited:

- a) If the Bidder withdraws the Bid after bid opening (opening of technical qualification part of the bid during the period of Bid validity;
- b) In the case of a successful Bidder, if the Bidder fails within the specified time limit to:
  - i. sign the Agreement; and/or
  - ii. Furnish the required Security Deposits/Performance Guarantee.

1. The cases wherein if the shortfalls are not complied by a contractor, will be informed to Registration and Monitoring Cell. Such non-submission of documents will be considered as 'Intentional Avoidance' and if three or more cases in 12 months are reported, shall be viewed seriously and disciplinary action against the defaulters such as banning/de-registration, etc. shall be taken by the registration cell with due approval of the concerned AMC.
2. No rejections and forfeiture shall be done in case of curable defects. For non-curable defects the 10% of EMD shall be forfeited and bid will be liable for rejection.

**Note:**

**i) Curable Defect shall mean shortfalls in submission such as:**

- a. Non-submission of following documents,
  - i. Valid Registration Certificate
  - ii. Valid Bank Solvency
  - iii. GST Registration Certificate
  - iv. Certified Copies of PAN documents and photographs of individuals, owners, etc.
  - v. Partnership Deed and any other documents.
  - vi. Undertakings as mentioned in the tender document.

**ii) Non-curable Defect shall mean**

- a. Inadequate submission of EMD amount,
- b. In-adequacy of technical and financial capacity with respect to Eligibility criteria as stipulated in the tender.
- c. Wrong calculation of Bid Capacity,
- d. No proper submission of experience certificates and other documents, etc.

## **6.18 BID VALIDITY**

Bids shall remain valid for a period of not less than one eighty (180) days after the deadline date for bid submission specified in Bid Data Sheet. A bid valid for a shorter period shall be rejected by the Employer as non-responsive.

In exceptional circumstances, prior to expiry of the original time limit, the Employer may request that the bidders may extend the period of validity for a specified additional period. The request and the bidders' responses shall be made in writing. A bidder may refuse the request without forfeiting his Bid Security. A bidder agreeing to the request will not be required or permitted to modify his bid, but will be required to extend the validity of his bid security for a period of the extension.

## **6.19 SECURITY DEPOSIT AND PERFORMANCE GUARANTEE**

### **A. Security Deposit**

The security deposit shall mean and comprise of

- I) Contract Deposit and
- II) Retention Money.

- I) **Contract Deposit** – The successful tender, here after referred to as the contractor shall pay an amount equal to **two (2)** percent of the contract sum shall be paid within thirty days from the date of issue of letter of acceptance.
- II) **Retention Money** – Not applicable.

**B. Additional Security Deposit**

The additional security deposit will be applicable when a rebate of more than 12% with no maximum limit. The ASD is calculated as follows:

$$\text{Additional security deposit} = (X/100) \times \text{office estimated cost,}$$

Where X=percentage rebate quoted above 12%.

The successful bidder shall submit the applicable A.S.D in the form of Demand Draft to BMC within 15 working days after issue of Letter of Acceptance and same shall be deposited to any CFC center of BMC. If the successful bidder fails to submit the applicable A.S.D. within 15 working days the E.M.D. Paid by the bidder will be forfeited and the company will be debarred for two years, similarly if the director/ partner of said company is also working in other company as a director/ partner of said company is also working in other company as a director/ partner the said company will also be debarred for two years.

**C. Performance Guarantee**

The successful tender, here after referred to as the contractor shall pay in the form of "Performance Guarantee" at different rates for different slabs as stated below:

<b>Offer</b>	<b>PG applicable %</b>
For premium, at par and rebate 0 to 12%	PG = 0.92% x contract sum <b>applicable for rebate of 12%</b>
For rebate of 12.01% and above	P.G. = {0.92% x contract sum applicable for rebate of 12%} + (X) x contract sum where, X= percentage rebate quoted more than 12%

Note: Contract sum shall mean amount after bid of rebate/premium as quoted by the contractor with contingencies only and excluding price variation.

The Performance Guarantee shall be paid in one the following forms.

- I) Cash (In case guarantee amount is less than Rs. 10,000/-)
- II) Demand Draft (in case guarantee amount is less than Rs.1,00,000/-)
- III) Government securities
- IV) Fixed Deposit Receipts (FDR) of a Schedule Bank.
- V) An electronically issued irrevocable bank guarantee bond of any Schedule bank or in the prescribed form given in Appendix.

Performance Guarantee is applicable over and above the clause of Security Deposits. Performance Guarantee will have to be paid & shall be valid till the Defect Liability period or finalization of final bill whichever is later.

This deposit will be allowed in the form of I to V as mentioned above and shall be paid within 15 days after receipt of Letter of Acceptance.

The Performance BG shall not be accepted in broken period else penalty amounting to Rs. 1000/- per day will be recovered for broken period.

## **6.20 Refund of Security Deposit, ASD & Performance Bank Guarantee**

### **I. Refund of Contract Deposit**

The Contract Deposit shall be released within 30 days after completion of the contract period subject to no recoveries are pending against the said work, provided that the Engineer is satisfied that there is no demand outstanding against the Contractor.

### **II. Refund of Retention Money**

Not Applicable.

### **III. Refund of Additional Security Deposit**

The additional security deposit shall be released within 30 days of issue of 'Certificate of Completion' with respect to the whole of the Works. In the event the Engineer issues a Taking-over Certificate for a section or part of the Permanent Works, only such proposition thereof as the Engineer determines (having regard to the relative value of such section or part of the Works) shall be considered by the Engineer for payment to the Contractor.

### **IV. Refund of Performance Guarantee**

The Deposit on account of performance guarantee shall be released within 30 days of completion of contract period subject to finalization of final bill whichever is later and no recoveries are pending against the said work, provided that the Engineer is satisfied that there is no demand outstanding against the Contractor.

Note:

- a) It shall be clearly mentioned that the BG shall be applicable for individual work/contract and clubbing of various contracts of the said contractor will not be allowed. In case of obtaining Bank Guarantee, it is necessary to mention that the same shall be valid further for minimum 6 months beyond the contract period.
- b) It shall be the responsibility of the bidder to keep the submitted B.G. "VALID" for the stipulated time period as mentioned in the tender & in case of its expiry it will attract penalization.
- c) Bank Guarantee should be issued by way of General Undertaking and Guarantee issued on behalf of the Contractor by any of the Nationalized or Scheduled banks or branches of foreign banks operating under Reserve Bank of India regulations located in Mumbai upto Virar & Kalyan. List of approved Banks is appended at Section 12. The Bank Guarantee issued by branches of approved Banks beyond Kalyan and Virar can be accepted only if the said Bank Guarantee is countersigned by the Manager of a Regional Branch of the same bank within the Mumbai City Limit categorically endorsing thereon that the said Bank Guarantee is binding on the endorsing Branch of the Bank or

the Bank itself within Mumbai Limits and is liable to be enforced against the said Branch of the Bank or the bank itself in case of default by the Contractors furnishing the Bank Guarantee. The Bank Guarantee shall be renewed as and when required and/or directed from time to time until the Contractor has executed and completed the works and remedied any defects therein.

### **6.21 Legal & Stationery Charges: (As per applicable circular)**

The payments towards legal charges, stamp duty as applicable (on contract agreement & bank guarantees), supply of bill forms & Tax certificates as per the prevailing rates shall be borne by successful Bidder. Successful tender shall pay the Legal Charges and Stationery charges as per Circular No. 10539 dated 28.03.2023.

<b>Contract Value</b>	<b>Legal &amp; Stationery Charges</b>
Rs. 10,001/- to Rs. 50,000/-	Nil
Rs. 50,001 to Rs. 1,00,000/-	Rs. 6,920/-
Rs. 1,00,001/- to Rs. 3,00,000/-	Rs.11,420/-
Rs. 3,00,001/- to Rs. 5,00,000/-	Rs. 13,720/-
Rs. 5,00,001/- to Rs. 10,00,000/-	Rs. 15,970/-
Rs. 10,00,001/- to Rs. 20,00,000/-	Rs. 18,230/-
Rs. 20,00,001/- to Rs. 40,00,000/-	Rs. 20,530/-
Rs. 40,00,001/- to Rs. 1,00,00,000/-	Rs. 22,800/-
Rs. 1,00,00,001/- to Rs. 10,00,00,000/-	Rs. 26,900/-
Rs. 10,00,00,001/- to Rs. 20,00,00,000/-	Rs. 31,050/-
Rs. 20,00,00,001/- to Rs. 30,00,00,000/-	Rs. 35,180/-
Rs. 30,00,00,001/- to Rs. 40,00,00,000/-	Rs. 39,320/-
Rs. 40,00,00,001/- to Rs. 50,00,00,000/-	Rs. 43,420/-
Rs. 50,00,00,001/- to Rs. 1,00,00,00,000/-	Rs. 51,700/-
Rs. 1,00,00,00,001/-to Rs. 2,00,00,00,000/-	Rs. 64,100/-
Rs. 2,00,00,00,001/- to Rs. 3,00,00,00,000/-	Rs. 72,350/-
Rs. 3,00,00,00,001/- to Rs. 4,00,00,00,000/-	Rs. 82,640/-
Rs. 4,00,00,00,001/- to Rs. 5,00,00,00,000/-	Rs. 92,970/-
Rs. 5,00,00,00,001/- and above without limit	Rs. 103,320/-

The above Legal and Stationery charges are applicable upto 31.03.2024. However, the contractor has to pay the Legal and Stationery charges at prevailing rates. Please note that stationary charges are recovered from the successful tenderer for supply of requisite prescribed forms for preparing certificate bills in respect of the work.

### **6.22 Stamp Duty: (As per applicable circular)**

It shall be incumbent on the successful Bidder to pay stamp duty on the contract.

- i. As per the provision made in Article 63, Schedule I of Maharashtra Stamp Act 2015, stamp duty is payable for "works contract" that is to say, a contract for works and labour or services involving transfer of property in goods (whether as goods or in some other form) in its execution and includes a sub-contract, as under (amended in 2015):

(a)	Where the amount or value set forth in such contract does not exceed Rupees Ten Lakh	Five Hundred Rupees Stamp Duty
(b)	Where it exceeds Rupees Ten Lakh	Five Hundred Rupees plus 0.1% of the amount above Rupees Ten Lakh subject to the maximum of Rupees Twenty Five Lakh Stamp Duty

**For Bank Guarantee:** 0.5% for the amount secured subject to maximum amount of Rs. Ten Lakhs. After expiry of Bank Guarantee (BG) if BG extended, the extended BG will be treated as new BG and stamp duty amount of 0.5% will be applicable for every extension.

- i. The successful bidder shall enter into a contract agreement with B.M.C. within 30 days from the date of issue of Letter of Acceptance and the same should be adjudicated for payment of Stamp Duty by the successful bidder.
- ii. Further shortfall if any, in amount of stamp duty paid as against prescribed amount for the documents executed in Mumbai City & Mumbai Suburban District be recovered from the concerned work contractors and to deposit the deficit or unpaid Stamp Duty and penalty by two separate Demand Draft or Pay Order in favour of "Superintendent of Stamp, Mumbai" within 15 days from intimation thereof.
- iii. All legal charges and incidental expenses in this respect shall be borne and paid by the successful tenderer.

### 6.23 Taxes and Duties on Material:

The tenderer shall quote inclusive of all taxes other than GST (Excluding GST), Levies, Duties, Cess etc as applicable at the time of bid submission. GST as applicable shall be paid separately on submission of bills/invoice.

Input Tax Credit of GST as available with the bidder will not be claim separately by BMC. However, while quoting the rates benefit of Input Tax Credit or Exemptions shall be passed on to the BMC by way of equivalent reduction in quoted price.

### 6.24 Payments Terms:

The bills for the executed works shall be submitted within prescribed time by the contractor and same will be certified by the Engineer as per BMC routine procedure of payment.

#### Submission of bills

The Contractor shall submit the bill for the work carried out within 15 days from the date of completion of the work to the respective executing department. If the

Contractor fails to submit their bills to concerned executing department for the completed works / running bill within 15 days, penalty or action as shown below will be taken for each delayed bill.

After 15 days from the date of completion / running bill upto certain date, upto next 15 days i.e. upto 30 days	Equal to 5% of Bill Amount
Next 15 days upto 45 days from the date of completion / running bill upto specified date.	Equal to 10% of Bill Amount
If not submitted within 45 days from the date of completion / R. A. Bill	Bill will not be admitted for payment

#### 6.25

The Contractor shall have his account with State Bank of India for any banking transaction and billing as the BMC makes payment through ECS/RTGS only.

#### 6.26 The Amount of Solvency Certificate Prescribed is as Under:

Total Estimated Cost (Rs. In Lakh)	Solvency Certificate Value
Without limit (For Class A)	Rs. 8 Lakhs

The Bank Solvency Certificate should be issued not more than Six months prior to the date of submission of Tender and valid upto one year.

#### 6.27 Penalty Clause:

There shall be regular review regarding the performance of the contractor by BMC. In case at any stage, it has been observed/ found that the performance of the contractor is unsatisfactory or discrepancies are found in the works carried out by contractor, BMC reserves the right to annul the contract after giving due opportunity and forfeit the performance Guarantee.

- a. The Engineer not below rank of Executive Engineer is entitle to imposed a penalty of minimum Rs. 1,000/- per day for each defective work / lapse, delay in work disobedience of orders, failure of the contractor to provide the services mentioned under the contract, non following instruction of Engineers etc. Penalty amount will be recovered from the contractors running bill. This penalty is over and above penalty mentioned below.
- b. In case of unsatisfactory performance, the office of Jt. Commissioner of Police (Traffic), who are the end users of the Speed Violation Detection System, may also propose penalty.
- c. If any ANPR camera or relevant accessories is found non working due to other utilities /infrastructural work, unforeseen Majeure, the penalty will not be levied for such occurrence.

- d. The maximum Penalty shall not exceed 10% of the contract value. If the penalty exceeds 10% of contract value the contractor will be debarred from further works of Brihanmumbai Municipal Corporation.
- e. Penalty will be levied as per Service Level Agreement (SLA) as shown below:

Sr. No.	Description	Resolution Time	Penalty after stipulated Resolution Time.
1	ANPR Camera shall be working properly.	Two Days	Rs. 100/- per day per equipment.
2	Radar shall be working properly.	Two Days	Rs. 100/- per day per equipment.
3	Illuminator shall be working properly.	Two Day	Rs. 100/- per day per equipment.
4	Local Processing Unit shall be working properly.	Two Day	Rs. 100/- per day per equipment.
5	Network connectivity shall be working continuously.	One Day	Rs. 100/- per junction per day
6	Operating system software, Control Center Software on server shall be working properly.	One Day	Rs. 1000/- per day
7	Restore/ Recovery of System Configuration of server shall be done in case of any hardware disaster.	Two Days	Rs. 1000/- per day
8	Server Hardware shall be working properly	Three Days	Rs. 1000/- per day
9	Material shall be procured in stipulated time period.	Stipulated period	0.5% of Material / equipment supply cost per Week
10	If any issue arises in hardware / software of Speed violation Detection system in the purview of OEM, then contractor will coordinate with OEM to resolve the issue.	Three Days	Rs. 2000/- Day

### 6.28 IMPORTANT DIRECTIONS:

- All the information uploaded shall be supported by the corroborative documents in absence of which the information uploaded will be considered as baseless and not accepted for qualification criteria. All the documents shall be uploaded with proper pagination. The page No. shall be properly mentioned in the relevant places.  
The information shall be uploaded in the sequence as asked for with proper indexing etc. The Bidder shall be fully responsible for the correctness of the information uploaded by him.

2. Bidders shall refer <https://portal.mcgm.gov.in\tenders> for "The Manual of Bid-Submission for Percentage Rate/Item Rate Tender Document." The detail guidelines for creation and submission of bid are available in the referred document.

Any queries or request for additional information concerning this TENDER shall be submitted by e-mail to [mcgmatc@gmail.com](mailto:mcgmatc@gmail.com). The subject shall clearly bear the following identification/ title: **"Queries/ Request for Additional Information: TENDER for "Maintenance of ANPR Cameras with associated accessories of Speed Violation Detection System in Brihanmumbai for the period of two years (01.09.2023 to 31.08.2025)."** Any changes in mail ID will be intimated on the portal.

3. In case of **Equal quote** of lowest bidders (L1), the allotment of work shall be done by giving 48 hrs (**2 working days**) from the day of opening of packet C **on same BID-Document number for re-quoting** and such development needs to be done by IT department in BMC's SRM system. **Till such development is made; 'Sealed Bids' shall be called from the bidders quoting the same rates i.e. L1.**

In case of equal percentage of lowest bidders is obtained even after re-quoting, then the successful bidder will be decided by lottery system by concerned Chief Engineer.

The bidder shall need to submit the additional ASD if applicable within 7 days after receipt of notification issued by concerned Chief Engineer.

## **6.29 Litigation History**

The bidder shall disclose the litigation history as mentioned in Packet 'B. If there is no litigation history, the bidder shall specifically mention that there is no litigation history against him. In case there is litigation history- Litigation History must cover – Any action of blacklisting, debarring, banning, suspension, deregistration and cheating with BMC, State Govt., Central Govt. or any authority under State or Central Govt./Govt. Organisation initiated against the company, firm, directors, partners or authorized signatory shall be disclosed for last 5 years from the date of submission of bid. Also, bidder must disclose the litigation history for the last 5 years from the date of submission of bid about any action like show caused issued, blacklisting, debarring, banning, suspension, deregistration and cheating with BMC and BMC is party in the litigation against the company, firm, directors, partners or authorized signatory for carrying out any work for BMC by any authority of BMC and the orders passed by the competent authority or by any Court where BMC is a party. While taking decision on litigation history, the concerned Chief Engineer or D.M.C. Or Director, as may be the case, should consider the details submitted by bidder and take decision based on the gravity of the litigation and the adverse effect of the act of company, firm, directors, partners or authorized signatory on the BMC works which can spoil the quality, output, delivery of any goods or any work execution and within the time frame.

## **6.30 GST – Anti Profiteering Measures**

"Chapter XXI-Miscellaneous, section 171(1) of GST Act, 2017 governs the 'Anti Profiteering Measure' (APM)

As per the provision of this section, 'Any reduction in rate of tax on any supply of goods or services or the benefit of input tax credit shall be passed on to the recipient by way of commensurate reduction in prices'

Accordingly, the contractor should pass on the complete benefit accruing to him on account of reduced tax rate or additional input tax credit, to BMC.

Further, all the provisions of GST Act will be applicable to the tender.”

- 6.31 The Successful Bidder should pay the Building & Other Construction Workers' Cess as per Building & Other Construction Workers' (Regulation of Employment and Conditions of Service) Act 1996. The Bidder should consider the same while submitting the offer.
- 6.32 After opening of Packet 'C', the first lowest bidder shall submit an undertaking on Rs. 500/- stamp paper that they will complete the work within stipulated period mentioned in tender. In case the work not completed within the stipulated period, penalty will be levied.
- 6.33 For “INTERNAL GRIEVANCE REDRESSAL MECHANISM” please refer circular no. Dy. Ch. E./ CPD/ 2025 dated 01.09.2021.

# **SECTION 7**

## **SCOPE OF WORK**

## **SCOPE OF THE WORK**

**Subject: Maintenance of ANPR Cameras with associated accessories of Speed Violation Detection System in Brihanmumbai for the period of two years (01.09.2023 to 31.08.2025).**

### **7.1 Preamble:**

At present 52 nos of ANPR Cameras are installed at various locations in Brihanmumbai for Speed Violation Detection System and 12 nos of ANPR camera will be installed at newly constructed flyover spanning at Ghatkopar Mankhurd Link Road. The technical details of existing system are attached separately under Section 10 of this tender document. Under this contract, the work of maintenance of 52 nos of existing ANPR Cameras and 12 nos of upcoming ANPR cameras & other allied equipment of Speed Violation Detection System is included. The maintenance is categorised in two parts as below:

- A. Preventive & Corrective Maintenance
- B. Damage Replacement Maintenance

#### **A. The scope of the work under Preventive & Corrective Maintenance is detailed below:**

- a) Preventive & Corrective maintenance of the existing Speed Violation System installed at various locations shall be carried out on monthly basis & report to that respect shall be submitted. The list of location shall be referred from Section 15.
- b) Following activities shall be carried out under Monthly Preventive & Corrective Maintenance.
  - 1. Cleaning of hardware of Speed Violation Detection System.
  - 2. Check all the cable terminations
  - 3. Check voltage of UPS
  - 4. Check proper functioning of UPS
  - 5. Applying Petroleum Gelly to battery terminals.
  - 6. Checking of Nut & bolts of Gantry. If found loose, tightened properly.
  - 7. Greasing of Nut Bolts of Junction box & Gantry.
  - 8. Checking of Alignment of Camera and Radar.
  - 9. Checking of Radar Angle by using Digital angle checker.
  - 10. Checking of Live streaming Video after carrying out of the above activities.
  - 11. Checking of Communication upto the Traffic Police Control Room.
  - 12. The successful contractor shall maintain history sheet for all the post commissioning activities carried out at the site and handover the same to department subsequently.
- c) The contractor shall utilised Truck mounted Aerial/ Boom Lift Crane for cleaning activity at respective location. The charges towards Utilisation of Truck mounted Aerial/ Boom Lift Crane vehicle shall be paid as per BOQ.

**B. The scope of the work under Damage Replacement Maintenance is detailed below:**

- a) The present Speed Violation Detection system is of Engine S.R.L. make. The contractor shall maintain the said system through out the contract period in working condition. Bill of Quantity mentioned in section 9 of this tender shall be executed as per the actual site requirement only after the joint site inspection by the BMC engineer and contractor. The successful contractor shall procure all the material required for execution of this work of approved make with valid BIS / IS / EN / relevant standards and as per BMC requirements / specifications. Successful Contractor shall produce the details of the equipment as insisted by the Engineer to prove the genuineness of the material. Non-approved make material shall be rejected.
- b) The contractor shall make sure that the material procured for this execution of this work shall be compatible and properly integrated with the existing system to avoid any hindrance/ non working of the system.
- c) The successful contractor shall coordinate with Traffic Police department for seeking their assistance required for traffic management during the execution of the maintenance work.
- d) It is sole responsibility of the successful contractor to coordinate with the existing Service Provider i.e. Engine, for any issue in the existing system. All the associated cost for the support of services provider shall be borne by the successful bidder. The successful contractor shall also be responsible for verification of data generated by the cameras is linked with e-Challan system of Traffic Police.
- e) The successful contractor shall provide necessary network connectivity at all the sites for communication between the site locations with the existing central server at Traffic Police Head Quarters. It is the responsibility of the successful contractor to maintain 24x7 network connectivity for all sites. All the expenses towards network connectivity shall be borne by contractor.
- f) Replacement of damaged ANPR cameras, Radars, Cabinets, Gantry, Cable, Chambers & Covers and associate equipments either by new one or supplied from BMC.
- g) Shifting of Speed Violation Detection System to other location if required due to various civic work.
- h) Liasoning with Network Provider, power supply companies, BMC Ward
- i) The system shall facilitate e-Challaning for speed violation and if any specific requirement in the vicinity of the system is required by Traffic Police Department then same shall be carried out without any extra cost.
- j) The contractor shall utilised Truck mounted Aerial / Boom Lift Crane for damage replacement work as and when required prior intimation to BMC Engineer.

**7.2 Terms & Conditions:**

- a) The bidders are requested to visit the work site before quoting for the bid to get themselves well acquainted with the site conditions and scope of work involved. No claim on this account will be entertained later on at any stage.

- b)** The successful contractor shall note that the work is to be executed during regular traffic flow without hampering smooth movements of the vehicles at other lanes than the work is being carried out with the assistance of Concerned Divisional Traffic Police personnels.
- c)** All the material used for this particular job shall be pre approved by the site Engineer and it shall be from fresh stock.
- d)** Necessary tools, tackles, equipment required for execution of this job shall be arranged by the successful contractor at his own cost.
- e)** The successful contractor shall take care of the men & material used at site for avoiding any accident /mishap at site.
- f)** The successful contractor shall make own arrangement for storing the material/equipment required for execution of work.
- g)** This is an entire job work of Maintenance of ANPR cameras installed for Speed Violation Detection System comprising of various components as per technical specifications.
- h)** The successful contractor shall have to submit the various documentation such as Guarantee/Warranty cards, Operation & Maintenance manuals, Test Report, Commissioning reports, challans of various procured material, photographs of the work (Before & after), records as insisted by site Engineer.
- i)** The successful contractor shall fulfilled the requirement as mentioned in Technical data of Annexure F along with supporting documents.

# **SECTION 8**

## **BILL OF QUANTITIES**

## Bill of Quantity

**Subject: Maintenance of ANPR Cameras with associated accessories of Speed Violation Detection System in Brihanmumbai for the period of two years (01.09.2023 to 31.08.2025).**

Sr. No.	Activity Number	Description	Unit	USOR Rate in Rs	BOQ	Amount in Rs.
1	R3-RT-ATC 11.17	Supply of Automatic Number Plate Recognition Camera (Infra-red) outdoor 2.8~12mm bullet camera with VCA as overview camera	Nos	88085.00	10.00	8,80,850.00
2	R3-RT-ATC 11.2	Installation, testing and commissioning of Outdoor Pan Tilt Zoom Integrated Dome Network Camera as mentioned above along with extension arm, if required.	Nos	9717.00	10.00	97,170.00
3	R3-RT-ATC 11.22	Supply of certified 4D HD Radar (Speed sensor) in compliance to legal metrology norms for speed enforcement upto 320 km/hr. The sensor should be able to cover up to 6 lanes and able to track a minimum 64 vehicles simultaneously. The speed accuracy should be as per OIML R 91 regulations. The sensor should also be certified for use in the proposed speed system with legal metrology standards for speed fines.	Nos	370000.00	9.00	33,30,000.00
4	R3-RT-ATC 11.18.B	Installation & Commissioning of Speed and vehicle classification radar sensor	Nos	15042.00	9.00	1,35,378.00
5	R3-RT-ATC 11.19.A	Supply of Additional illuminator for ANPR	Nos	39042.00	5.00	1,95,210.00
6	R3-RT-ATC 11.19.B	Installation & Commissioning of Additional illuminator for ANPR	Nos	7385.00	5.00	36,925.00
7	R3-RT-ATC 11.21.A	Supply of Road side processing unit with Processor, storage, communication modem, battery	Nos	220751.00	2.00	4,41,502.00

		charger, watch dog module and IP66 casing, cabling, mounting brackets and fixtures				
8	R3-RT-ATC 11.21.B	Installation & Commissioning of Road side processing unit with Processor, storage, communication modem, battery charger, watch dog module and IP66 casing, cabling, mounting brackets and fixtures	Nos	36924.00	2.00	73,848.00
9	R3-RT-ATC-1.8	Installation,testing and commissioning of all types of ATC controller	Nos	16146.00	4.00	64,584.00
10	R3-ME-12-4-B	SITC CAT -6 Gigabyte	Mtr	34.00	1000.00	34,000.00
11	R3-RT-ATC 7.2	Supply of PVC insulated armoured cable - 2.5 Sq.mm. 3 core copper conductor	Mtr	109.00	2000.00	2,18,000.00
12	R3-RT-ATC 7.14	Laying of signal cables (all types including communication cables with multi pairs as described above) in trenches, existing ducts / G.I. Pipes including ferruling, testing etc. but excluding any cable joint, excavation etc.	Mtr	37.00	2000.00	74,000.00
13	R3-RT-NATC 3.5	Supply of single 50 mm (OD)/ 37 mm (ID) double walled corrugated High Density Poly Ethylene (HDPE) Pipes conforming to the IS 16205 (Part-24) including supply of necessary sockets, couplings etc.	Mtr	41.00	1000.00	41,000.00
14	R3-RT-NATC 3.6	Laying 50 mm (OD)/ 37mm (ID) double walled corrugated High Density Poly Ethylene (HDPE) Pipes including pull wire along with necessary sockets, couplings etc. as per drawing no. RT-NATC-3.2A & RT-NATC-3.2B	Mtr	7.00	1000.00	7,000.00
15	R3-RT-14.15	Excavation of trench for traffic signals and VMS boards cables and con-	Cum	1208.00	300.00	3,62,400.00

		duiting as per requirement of the signal junction up to the depth of 600mm below the ground surface and width 500mm in the footpath/soft soil including refilling of the trench in footpath and removal of debris as per the BMC guidelines.				
16	R3-RT- ATC 11.9	Monthly Preventive and Corrective Maintenance of per CCTV/ANPR of camera	Nos	2980.00	1392.00	41,48,160.00
17	R3-RT-ATC 11.10	CCTV Server Comprehensive Maintenance Yearly	Nos	163912.00	2.00	3,27,824.00
18	R3-ME-7-1-c	Earthing station with 600 mm x 600 mm x 6 mm galvanised iron plate & 50 mm dia. G.I. pipe, 3000mm long GI pipe (Class B or better) earth pit as per IS 3043. The earth pit shall be provided with watering pipe (Class B) with wire messed funnel, 25x3 GI strip / 8 SWG GI wire up to chamber (wire or strip size as per fault level), disconnecting links with 600 x 600 mm (clear) RCC chamber & heavy duty 3 mm thick CI chequered plate cover with hinge & stainless steel bolts. Bentonite/ Charcol & Salt shall be provided for earth pits. Excavation, backfilling, removal of excess soil is included in the scope.	Nos	16475.00	8.00	1,31,800.00
19	R3-ME-7-4-e	Supply & installation of Earth conductor of the following sizes to be cleated on wall / columns with nuts & bolts or laid in cable tray / buried in ground including cutting, drilling, tapping, jointing by welding, connecting to equipments, painting to welded portion by black bitumen paint and with all	Mtr	50.00	1800.00	90,000.00

		necessary GI hardware & accessories to complete the work Earthing Continuity Conductors -25 x 3mm GI				
20	R3-RT-ATC 10.65	Rent for 12 Mtr MACLIFTON for CCTV and Video Detection Cameras per shift( 8 HRS SHIFT)	Nos	10028.00	120.00	12,03,360.00
21	R3-RT- NATC 8.8	Supply of Battery 12V / 65 AH	Nos	5748.00	5.00	28,740.00
22	R3-RT- ATC 12.8	Removal of VMS pole / Gantry its assembly	Nos	53038.00	2.00	1,06,076.00
23	R3-RT-ATC- 15.15	Installation of Gantry for 2/3 Lane	Nos	32628.00	2.00	65,256.00
24	R3-RT-ATC- 16.5	Construction of foundation of ANPR gantry concrete M20 grade rectangle in shape (LXWXH) (1100mmX600mmX600mm) above and below ground level	Nos	27828.00	2.00	55,656.00
25	R3-RT-ATC 10.19	Server for CCTV/ANPR HP ProLiant DL380p Gen8 (1) Intel® Xeon® E5-2643 (3.3GHz/ 4-core/10MB/8 GT-s QPI/130 W) Processor/ 10MB (1x10MB) Level 3/ 16 GB RAM PC3L-10600R (DDR3-1333) Registered DIMMS/HP Smart Array P420i/ZM (RAID 0/1/1+0)/ 8 SFF SAS/ SATA HDD Bays; includes 6 SFF hard drive blanks/ (1) HP 460W Common Slot Gold Hot Plug Power Supply (92% Efficient)/ 3 Years 24x7 Onsite Warranty Server for CCTV HP ProLiant DL380p Gen8 (1) Intel® Xeon® E5-2643 (3.3GHz/	Nos	854087	1.00	8,54,087.00
<b>Total Amount in Rs.</b>						<b>1,30,02,826.00</b>

Note: As per the information received from BMC Tax Consultant, the present rate of GST on this work contract is 18% for SAC Code 998719 applicable.

# **SECTION 9**

## **GENERAL CONDITIONS OF CONTRACT**

**GENERAL CONDITIONS OF CONTRACT - DEFINITION AND  
INTERPRETATION**

General Conditions of Contract (G.C.C.) revised up to date, are available on BMC web site '<https://portal.mcgm.gov.in>' for reference.

# **SECTION 10**

## **SPECIFICATIONS & SELECTION OF MATERIAL**

**Subject: Maintenance of ANPR Cameras with associated accessories of Speed Violation Detection System in Brihanmumbai for the period of two years (01.09.2023 to 31.08.2025).**

**10.1 General:**

The subject work is of maintenance of ANPR camera with associated accessories of Speed Violation Detection System in Brihanmumbai at locations mentioned in Section 15. The scope of work is covered in the Section 7 of this tender document.

**10.2 Technical data sheet of various componetns of the existing system are given below.**

a) Introduction of Automatic Number Plate Recognition System for Speed Violation Detection System.

The system consist of a Vista EnVES Series Camera, SPEED TAB RADAR (one of them each for every lane to be monitored), one more or processor unit EnCZ4b/Nuvo-5501 series to process, store and make available data collected by transit lane monitored and workstation that allows the operator to view transit.

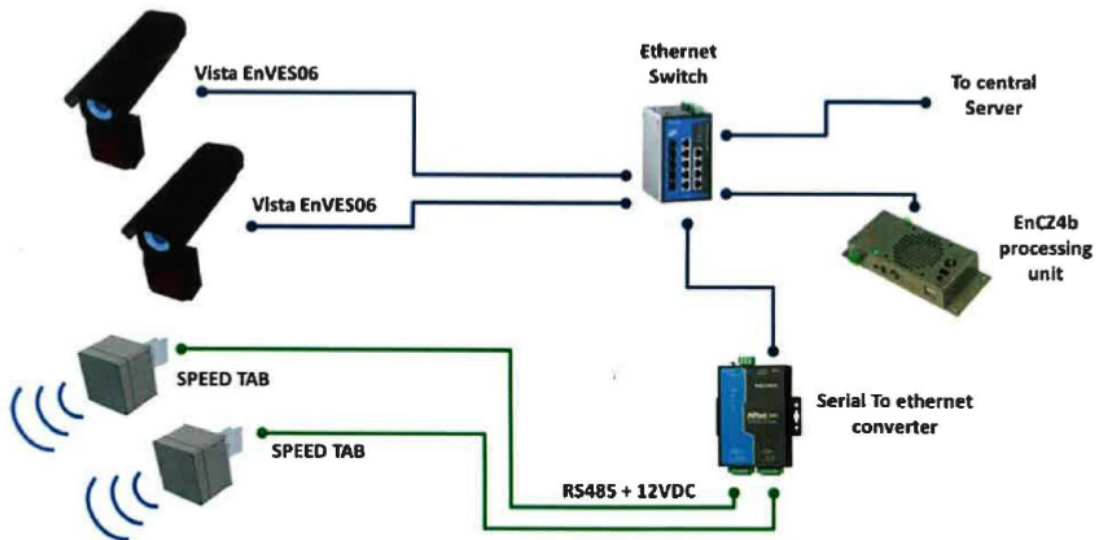

The components of SVDS system are as below:

i. **CAMERA:** Image acquisition system Vista EnVES06 Vista EnVES cameras is family of image acquisition system specifically designed for enforcing (like instant speed and RLVD) and ANPR applications. This camera can monitor single lane. The apparatus consists of a Vista EnVES Megapixel camera into enclosure with integrated infrared illuminator. Vista EnVES06 camera has an external IR which is integrated with the camera. This provides easy installation. The IR is suitable for high distances and can be used at gantries or side poles. The EnIR20 series IR powerful illuminators are specially designed for enforcing applications and for better plate recognition. Technical specification of IR Illuminator

- Type: IR illuminator 780 nm/ 850 nm/930 nm
- Illumination Range: 15 to 20 feet

- Environment Protection: IP67

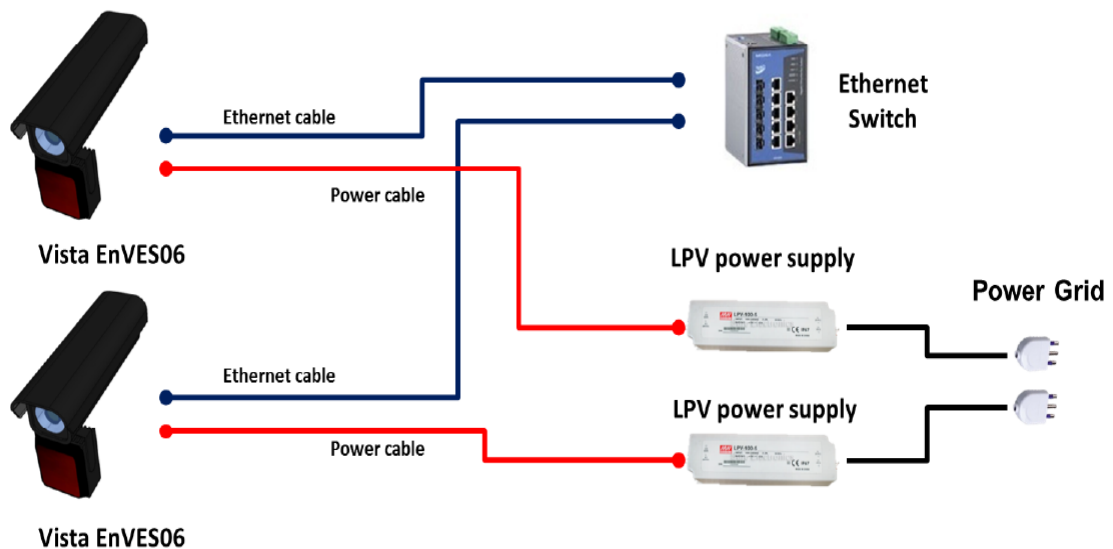

## ii. SPEED TAB SENSOR(2D)/4D Radar:

The microwave sensor SPEED TAB 2D Radar/4D Radar (Smart Micro UMRR-11 Type 44) is a doppler radar with the latest generation of signal processing. This allows good separation of vehicles and accurate speed readings even in heavy traffic. The signals are processed by a microprocessor that uses a proprietary algorithm to provide for each transit accurate readings vehicle speed, length and direction. 2D SPEED TAB Radar is used for single lane whereas 4D Radar for multi lane purpose.

Sr. No.	Feature of 2D radar	Details
1	Housing	Polycarbonate
2	Dimensions	180x180x110 mm
3	Operating frequency	24.15 GHz – K band
4	Max transmitted power	16 dBm
5	Communication	RS485
6	Temperature range	-15°C ~ +55°C
7	Power supply	10,5V ~ 14 VDC
8	Current consumption	120 mA

<b>Sr. No.</b>	<b>Features of 4D Radar</b>	<b>Details</b>
1	Radar Type	4D HD
2	Capability	Shall be capable of covering of 6 lane
3	Detection Targets	1. Four wheelers (Car, Trucks, Buses) 2. Three wheelers 3. Two Wheelers (Scooter/Motor Cycle)
4	Detection Range	1. Minimum Range at least 20 m 2. Max Range Passenger car-140 m Truck- 180 m
5	Speed Range	30 kmph (or lower desirable) and 250 kmph
6	Speed accuracy	<+/- 0.28 m/s +/-1% (bigger of)
7	Tracking	Simultaneously able to track at least 64 objects
8	Azimuth FOV	Azimuth Angle: -50...+50°)
9	Form Factor	Enclosed Rugged, Watertight Casing (Metal/Polycarbonate (UV Stabilized) Pole Mount.
10	IP Protection	IP 66 or Better
11	Operating Temperature	-40 to +80 degree
12	Shock	100grms
13	Vibration	14grms
14	Frequency Band	EIRP 24.0 to 24.25 GHz (K Band) better than 20dBm
15	Input Power	12 to 32 VDC : 5.0 Watts
16	Serial	Communication Interface RS485
17	Ethernet	Compatible interface modules Ethernet
18	Simulator Interface	Windows, Linux
19	Testing	Proper Test Reports and Certification for Speed in accordance to OIML R 91
20	Certifications	CE/EN, FCC, NEMA

SPEED TAB sensor uses an industrial standard RS485 serial protocol to connect with the processing unit. The device is provided with a dedicated sealed connector with screw terminals. The cable used can be a single standard UTP cable.

For the conversion to Ethernet is used a two port MOXA Ethernet to serial converter with a proper configuration. In this way data from the radar sensor are transmitted to the processor EnCZ4b /Nuvo-5501 Series processor via Ethernet connection.

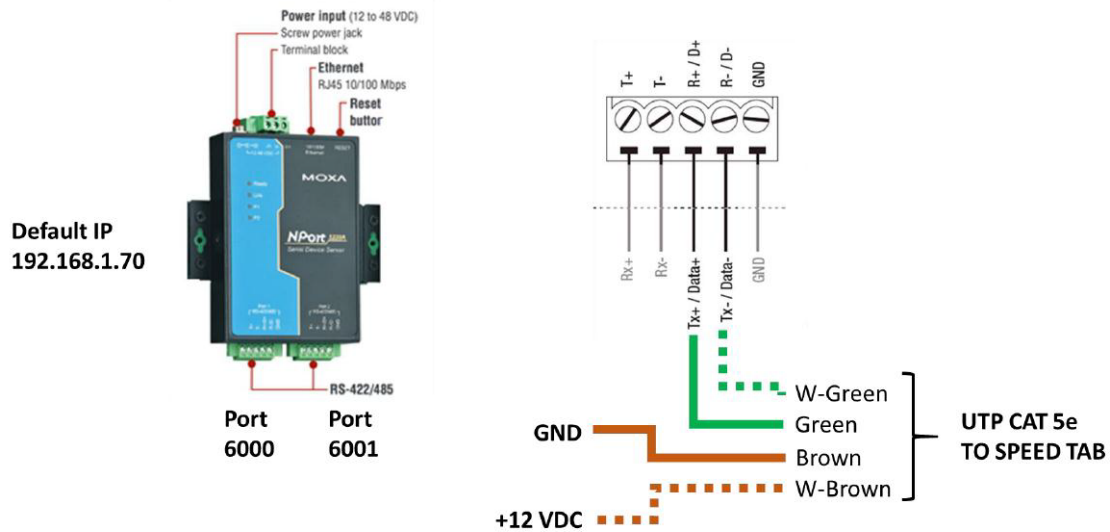

**iii. Road Side Processing Unit:** EnCZ4b processor unit / Nuvo-5501 Series Intel® 6th-Gen Core™ i5 Compact Fanless Embedded Controller with 3x GbE, is an industrial embedded processor used by EngiNe for use in road violations detection context.

**iv. Server Details: EnVES / CELERITAS server (ECS -EngiNe Centralization Server)**

Make & Model	HPE DL180Gen9
Serial No	SGH711TJ49
Processor	Intel XeonE5-2620V4
RAM	16GB DDR-4 RAM
Storage	12 TB
Operating System	CentOs Version 7, Freeware Open license
Database	PostgreSQL

**v. Software Details:**

ECS server contains a software module called EIM (**ECS Integration Module**) that permits integration with other systems. Interaction is basically done in two ways: using web API (Application Programming Interface) or by downloading a data file that contains all violations and images.

**Web API:**

Web API allows a third party's software to interact with ECS Server querying all transits detected in a specified time interval. The software may query the transit list and, if it is a violation, it is possible to query images. Web API can also be used to get additional information about ECS Server.

Web API are implemented as REST services: all requests are addressed to ECS Server web server performing an https request to a specific URL of the server by specifying appropriate parameters; the answer to the request is a buffer (according to requested data type) or an http error code. The request must be authenticated according to methods Parameters are passed to REST services using Http GET form commands that read information from ECS and using Http POST when used with commands that modify ECS.

**File download** A data file that contains violations and relative images can be exported in one of the following ways, which both produce a data file.

**Download file from server GUI** The user connects to the GUI with a web browser using his credentials, selects from the menu the Export page, enters the parameters and downloads the data file. This mode is always accessible and can be used if, for some reason, is not available the third party's software.

**Direct access through URL** Application software (eventually a browser) access through an https request to a specific URL of the server by specifying appropriate parameters; the answer to the request is a data file or an http error code. The request must be authenticated using the Basic http authentication with the credentials of a user authorized to access the server to download the data.

The Detailed API will be shared to the successful contractor after awarding the work.

### **10.3 Technical Specification of items:**

- a) Please refer the Traffic USOR-2023 of Technical Specification for entire BOQ items which are covered under this work. The USOR-2023 is available on BMC portal.
- b) The higher technical specification will be acceptable and the same shall be compatible and properly integrated to the existing system. No extra cost will be applicable for the same.
- c) BMC reserves right to order for procurement of any item covered to any extent i.e. in the quantities, as per site conditions / requirements prevailing at the time of execution of work and as per the requirements and / or recommendations of Traffic Police. As such, the Items included in B.O.Q. may not be executed to the extent of the respective quantity incorporated in B.O.Q. depending upon the site conditions. The Tenderer shall not be entitled for any compensation on this account.
- d) The Bidder shall procure all material required for the repair work/ new equipments and materials of approved make with valid BIS / IS / EN / relevant standards certificates and as per BMC requirements / specifications wherever applicable. Bidder shall produce on demand such details as called by the Engineer to prove the genuineness of the material. Non-approved material shall be rejected.

<b>Sr. No.</b>	<b>Item Code</b>	<b>Item Description</b>	<b>Technical Specification</b>
1	R3-RT-ATC 11.17	Supply of Automatic Number Plate Recognition Camera (Infra-red) outdoor 2.8~12mm bullet camera with VCA as overview camera	As per Technical Specification of Traffic USOR-2023.
2	R3-RT-ATC 11.2	Installation, testing and commissioning of Outdoor Pan Tilt Zoom Integrated Dome Network Camera as mentioned above along with extension arm, if required.	The item shall be read as Installation, Testing & Commissioning of ANPR camera on Gantry. The old camera shall be removed properly before installation.
3	R3-RT-ATC 11.22	Supply of certified 4D HD Radar (Speed sensor) in compliance to legal metrology norms for speed enforcement upto 320 km/hr. The sensor should be able to cover up to 6 lanes and able to track a minimum 64 vehicles simultaneously. The speed accuracy should be as per OIML R 91 regulations. The sensor should also be certified for use in the proposed speed system with legal metrology standards for speed fines.	The existing system have 2D & 4D Radar installed. In case of 2D radar get faulty, then such Radar shall replaced by 4D Radar as per technical specification of Traffic USOR-2023.
4	R3-RT-ATC 11.18.B	Installation & Commissioning of Speed and vehicle classification radar sensor	As per Technical Specification of Traffic USOR-2023.
5	R3-RT-ATC 11.19.A	Supply of Additional illuminator for ANPR	As per Technical Specification of Traffic USOR-2023.
6	R3-RT-ATC 11.19.B	Installation & Commissioning of Additional illuminator for ANPR	As per Technical Specification of Traffic USOR-2023.
7	R3-RT-ATC 11.21.A	Supply of Road side processing unit with Processor, storage, communication modem, battery charger, watch dog module and IP66 casing, cabling, mounting brackets and fixtures	As per Technical Specification of Traffic USOR-2023.
8	R3-RT-ATC 11.21.B	Installation & Commissioning of Road side processing unit with Processor, storage, communication modem, battery charger, watch dog module and IP66 casing, cabling, mounting brackets and fixtures	As per Technical Specification of Traffic USOR-2023.

9	R3-RT-ATC-1.8	Installation,testing and commis- sioning of all types of ATC con- troller	Installation, testing and commis- sioning of Controller Box of ANPR system at respective location. The Controller cabinet will be is- sued by BMC.
10	R3-ME-12-4-B	SITC CAT -6 Gigabyte	As per Technical Specification of Traffic USOR-2023. Preferred make: D-Link
11	R3-RT-ATC 7.2	Supply of PVC insulated armoured cable - 2.5 Sq.mm. 3 core copper conductor	As per Technical Specification of Traffic USOR-2023.
12	R3-RT-ATC 7.14	Laying of signal cables (all types including communication cables with multi pairs as described above) in trenches, existing ducts / G.I. Pipes including ferruling, testing etc. but excluding any ca- ble joint, excavation etc.	As per Technical Specification of Traffic USOR-2023.
13	R3-RT- NATC 3.5	Supply of single 50 mm (OD)/ 37 mm (ID) double walled corru- gated High Density Poly Ethylene (HDPE) Pipes conforming to the IS 16205 (Part-24) including sup- ply of necessary sockets, cou- plings etc.	As per Technical Specification of Traffic USOR-2023.
14	R3-RT- NATC 3.6	Laying 50 mm (OD)/ 37mm (ID) double walled corrugated High Density Poly Ethylene (HDPE) Pipes including pull wire along with necessary sockets, couplings etc. as per drawing no. RT-NATC- 3.2A & RT-NATC-3.2B	As per Technical Specification of Traffic USOR-2023.
15	R3-RT- 14.15	Excavation of trench for traffic signals and VMS boards cables and conduiting as per requirement of the signal junction up to the depth of 600mm below the ground surface and width 500mm in the footpath/soft soil including refilling of the trench in footpath and re- moval of debris as per the BMC guidelines.	As per Technical Specification of Traffic USOR-2023. The item will be paid as per ac- tual measurement of depth, width & length of the trench.
16	R3-RT- ATC 11.9	Monthly Preventive and Corrective Maintenance of per CCTV/ANPR of	As per Technical Specification of Traffic USOR-2023.

		camera	Monthly service report shall be submitted to the BMC.
17	R3-RT-ATC 11.10	CCTV Server Comprehensive Maintenance Yearly	As per Technical Specification of Traffic USOR-2023. Monthly activity of server health check up shall be carried out. The payment will be made on quarterly basis.
18	R3-ME-7-1-c	Earthing station with 600 mm x 600 mm x 6 mm galvanised iron plate & 50 mm dia. G.I. pipe, 3000mm long GI pipe (Class B or better) earth pit as per IS 3043. The earth pit shall be provided with watering pipe (Class B) with wire meshed funnel, 25x3 GI strip/ / 2X8SWG G.I. wire up to chamber (wire or strip size as per fault level), disconnecting links with 600 x 600 mm (clear) RCC chamber & heavy duty 3mm thick CI chequered plate cover with hinge & stainless steel bolts. Bentonite/ Charcol & Salt shall be provided for earth pits. Excavation, back filling, removal of excess soil is included in the scope	As per Technical Specification of M&E USOR-2023
19	R3-ME-7-4-e	Supply & installation of Earth conductor of the following sizes to be cleated on wall / columns with nuts & bolts or laid in cable tray / buried in ground including cutting, drilling, tapping, jointing by welding, connecting to equipments, painting to welded portion by black bitumen paint and with all necessary GI hardware & accessories to complete the work Earthing Continuity Conductors - 25 x 3mm GI	As per Technical Specification of M&E USOR-2023.
20	R3-RT-ATC 10.65	Rent for 12 Mtr Mac-lifto for CCTV and Video Detection Cameras per shift (8 Hrs Shift).	The item shall be read as Rent for Truck mounted Aerial / Boom Lift Crane for ANPR cameras per shift (8 Hrs shift) It shall be utilised total 3 shifts per month for preventive & Cor-

			rective Maintenance and for damage replacement work it will be utilised as and when required with prior intimation to BMC Engineer.
21	R3-RT-NATC 8.8	Supply of Battery 12V / 65 AH	As per Technical Specification of Traffic USOR-2023. Preferred make :Exide
22	R3-RT- ATC 12.8	Removal of VMS pole / Gantry its assembly	As per Technical Specification of Traffic USOR-2023.
23	R3-RT-ATC-15.15	Installation of Gantry for 2/3 Lane	As per Technical Specification of Traffic USOR-2023.
24	R3-RT-ATC-16.5	Construction of foundation of ANPR gantry concrete M20 grade rectangle in shape (LXWXH) (1100mmX600mmX600mm) above and below ground level	As per Technical Specification of Traffic USOR-2023.
25	R3-RT- ATC 10.19	Server for CCTV HP ProLiant DL380p Gen8 (1) Intel® Xeon® E5-2643 (3.3GHz/4-core/10MB/8 GT-s QPI/130 W) Processor/ 10MB (1x10MB) Level 3/ 16 GB RAM PC3L-10600R (DDR3-1333) Registered DIMMS/HP Smart Array P420i/ZM (RAID 0/1/1+0)/ 8 SFF SAS/SATA HDD Bays; includes 6 SFF hard drive blanks/ (1) HP 460W Common Slot Gold Hot Plug Power Supply (92% Efficient)/ 3 Years 24x7 Onsite WarrantyServer for CCTV HP ProLiant DL380p Gen8 (1) Intel® Xeon® E5-2643 (3.3GHz/	As per Technical Specification of Traffic USOR-2023.

# **SECTION 11**

## **FRAUD AND CORRUPT PRACTICES**

## **FRAUD AND CORRUPT PRACTICES**

- The bidders and their respective officers, employees, agents and advisers shall observe the highest standard of ethics during the Bidding Process. Notwithstanding anything to the contrary contained herein, the Authority may reject bid without being liable in any manner whatsoever to the bidder if it determines that the bidder has, directly or indirectly or through an agent, engaged in corrupt practice, fraudulent practice, coercive practice, undesirable practice or restrictive practice in the Bidding Process.
- Without prejudice to the rights of the Authority under relevant Clause herein above, if a bidder is found by the Authority to have directly or indirectly or through an agent, engaged or indulged in any corrupt practice, fraudulent practice, coercive practice, undesirable practice or restrictive practice during the Bidding Process, such bidder shall not be eligible to participate in any tender or RFQ issued by the Authority during a period of 2 (two) years from the date such bidder is found by the Authority to have directly or indirectly or through an agent, engaged or indulged in any corrupt practice, fraudulent practice, coercive practice, undesirable practice or restrictive practice, as the case may be.
- For the purposes of this Clause, the following terms shall have the meaning hereinafter respectively assigned to them:
  - A. **“corrupt practice”** means the offering, giving, receiving, or soliciting, directly or indirectly, of anything of value to influence the actions of any person connected with the Bidding Process (for avoidance of doubt, offering of employment to, or employing, or engaging in any manner whatsoever, directly or indirectly, any official of the Authority who is or has been associated in any manner, directly or indirectly, with the Bidding Process or the LOA or has dealt with matters concerning the Concession Agreement or arising there from, before or after the execution thereof, at any time prior to the expiry of one year from the date such official resigns or retires from or otherwise ceases to be in the service of the Authority, shall be deemed to constitute influencing the actions of a person connected with the Bidding Process); or save and except as permitted under the relevant sub clause, engaging in any manner whatsoever, whether during the Bidding Process or after the issue of the LOA or after the execution of the Concession Agreement, as the case may be, any person in respect of any matter relating to the Project or the LOA or the Concession Agreement, who at any time has been or is a legal, financial or technical adviser of the Authority in relation to any matter concerning the Project;
  - B. **“fraudulent practice”** means a misrepresentation or omission of facts or suppression of facts or disclosure of incomplete facts, in order to influence the Bidding Process;
  - C. **“coercive practice”** means impairing or harming or threatening to impair or harm, directly or indirectly, any person or property to influence any persons participation or action in the Bidding Process;
  - D. **“undesirable practice”** means (i) establishing contact with any person connected with or employed or engaged by the Authority with the objective of canvassing,

lobbying or in any manner influencing or attempting to influence the Bidding Process; or (ii) having a Conflict of Interest; and

- E. **“Restrictive practice”** means forming a cartel or arriving at any understanding or arrangement among bidders with the objective of restricting or manipulating a full and fair competition in the Bidding Process.
- F. If the Employer/Financier determines that the Contractor has engaged in corrupt, fraudulent, collusive, coercive or obstructive practices, in competing for or in executing the Contract, then the Employer may, after giving 14 days’ notice to the Contractor, terminate the Contractor’s employment under the Contract and expel him from the Site, and the provisions of relevant Clause shall apply as if such expulsion had been made.
- G. Should any employee of the Contractor be determined to have engaged in corrupt, fraudulent, collusive, coercive, or obstructive practice during the execution of the Works, then that employee shall be removed in accordance with relevant Clause.

For the purposes of this Sub-Clause:

- i. “corrupt practice” is the offering, giving, receiving to soliciting, directly or indirectly, of anything of value to influence improperly the actions of another party;
- ii. “another party” refers to a public official acting in relation to the procurement process or contract execution. In this context, “public official” includes Finance staff and employees of other organizations taking or reviewing procurement decisions.
- iii. “fraudulent practice” is any act or omission, including a misrepresentation, that knowingly or recklessly misleads, or attempts to mislead, a party to obtain a financial or other benefit or to avoid an obligation;
- iv. “collusive practice” is an arrangement between two or more parties designed to achieve an improper purpose, including to influence improperly the actions of another party;
- v. “coercive practice” is impairing or harming, or threatening to impair or harm, directly or indirectly, any party or the property of the party to influence improperly the actions of a party;
- vi. “obstructive practice” is deliberately destroying, falsifying, altering or concealing of evidence material to the investigation or making false statements to investigators in order to materially impede the Financier investigation into allegations of a corrupt, fraudulent, coercive or collusive practice; and/or threatening, harassing or intimidating any party to prevent it from disclosing its knowledge of matters relevant to the investigation or from pursuing the investigation; or
- vii. acts intended to materially impede the exercise of the Financier’s inspection and audit rights provided.

- viii. "party" refers to a public official; the terms "benefit" and "obligation" relate to the procurement process or contract execution; and the "act or omission" is intended to influence the procurement process or contract execution.
- ix. "parties" refers to participants in the procurement process (including public officials) attempting to establish bid prices at artificial, noncompetitive levels.
- x. a "party" refers to a participant in the procurement process or contract execution.

# **SECTION 12**

## **LIST OF APPROVED BANKS**

## **LIST OF APPROVED BANKS**

1. The following Banks with their branches in Brihanmumbai and upto Virar and Kalyan have been approved only for the purpose of accepting Banker's Guarantee from 1997-98 onwards until further instructions.
2. The Bankers Guarantee issued by branches of approved Banks beyond Kalyan and Virar can be accepted only if the said Banker's Guarantee is countersigned by the Manager of a Branch of the same Bank, within the Mumbai City Limit categorically endorsing thereon that said bankers Guarantee is binding on the endorsing Branch of the Bank with Mumbai limits and is liable to be on forced against the said branch of the Bank in case of default by the contractor/ supplier furnishing the Bankers Guarantee.

### **List of the Approved Banks**

#### **(A) S.B.I. and its subsidiary Banks:**

- (1) State Bank of India
- ~~(2) State Bank of Bikaner & Jaipur~~
- (3) State Bank of Hyderabad
- (4) State Bank of Mysore
- (5) State Bank of Patiala
- (6) State Bank of Saurashtra
- (7) State Bank of Travankore

#### **(B) Nationalised Banks:**

- (8) Allahabad Bank
- (9) Andhra Bank
- (10) Bank of Baroda
- (11) Bank of India
- (12) Bank of Maharashtra
- (13) Central Bank of India
- (14) Dena Bank Indian
- (15) Indian Bank
- (16) Overseas Bank
- (17) Oriental Bank of Commerce
- (18) Punjab National Bank
- (19) Punjab & Sind Bank
- (20) Syndicate Bank
- (21) Union Bank of India
- (22) United Bank of India
- (23) UCO Bank
- (24) Vijaya Bank
- (25) Corporation Bank

#### **(C) Scheduled Commercial Banks:**

- (26) Bank of Madura Ltd.
- (27) Bank of Rajasthan Ltd.
- (28) Banaras State Bank Ltd.
- (29) Bharat Overseas Bank Ltd.
- (30) Catholic Syrian Bank Ltd.
- (31) City Union Bank Ltd.
- (32) Development Credit Bank
- (33) Dhanalakshmi Bank Ltd.
- (34) Federal Bank Ltd.
- (35) Indus Ind. Bank Ltd.
- (36) I.C.I.C.I. Banking Corporation Ltd.
- (37) Global Trust Bank Ltd.
- (38) Jammu and Kashmir Bank Ltd.
- (39) Karnataka Bank Ltd.
- (40) Karur Vysya Bank Ltd.
- (41) Lakshmi Vilas Bank Ltd.
- (42) Nadungadi Bank Ltd.
- (43) Ratnakar Bank Ltd.
- (44) Sangli Bank Ltd.
- (45) South Indian Bank Ltd.
- (46) S.B.I. Commercial & Int. Bank Ltd.
- (47) Tamilnadu Mercantile Bank Ltd.
- (48) United Western Bank Ltd.
- (49) Vysya Bank Ltd.

**(D) Scheduled Urban Co-op. Banks:**

- (50) Abhyudaya Co.op.Bank Ltd.
- (51) Bassein Catholic Co.op. Bank Ltd.
- (52) Bharat Co.op. Bank Ltd.
- (53) Bombay Mercantile Co.op. Bank Ltd.
- (54) Cosmos Co.op. Bank Ltd.
- (55) Greater Mumbai Co.op. Bank Ltd.
- (56) Janata Sahakari Bank Ltd.
- (57) Mumbai Dist.Central Co.op. Bank Ltd.
- (58) Maharashtra State Co.op. Bank Ltd.
- (59) New India Co.op. Bank Ltd.
- (60) North Canara G.S.B.Co.op. Bank Ltd.
- (61) Rupee Co.op. Bank Ltd.
- (62) Sangli Urban Co.op. Bank Ltd.
- (63) Saraswati Co.op. Bank Ltd.
- (64) Shamrao Vithal Co.op. Bank Ltd.
- (65) Mahanagar Co-op. Bank Ltd.
- (66) Citizen Bank Ltd.
- (67) Yes Bank Ltd.

**(E) Foreign Banks:**

- (68) AMRO (N.Y.) Bank.
- (69) American Express Bank Ltd.
- (70) ANZ Grindlays Bank
- (71) Bank of America N.T. & SA.
- (72) Bank of Tokyo Ltd.
- (73) Bank Indosuez
- (74) Banque Nationale de Paris
- (75) Barclays Bank
- (76) City Bank N.A.
- (77) Hongkong & Shanghai Banking Corpn.
- (78) Mitsui Taiyokbe Bank Ltd.
- (79) Standard Chartered Bank Ltd.
- (80) Cho Hung Bank

In addition to the list of banks provided above for bank guarantee, following banks in the list of RBI (Reserve Bank of India) will also be allowed. RBI's list of the banks can be downloaded from [www.rbi.org.in](http://www.rbi.org.in) . From this list of RBI bank under following heads with their branches in Brihanmumbai and in Suburbs and extended suburbs upto Virar and Kalyan have been approved for Bank Guarantee:-

SBI and Associates, Nationalised Banks, Other Public Sector Banks, Private Sector Bank, Foreign Banks and Urban Co Operative Banks.

# **SECTION 13**

## **SPECIAL INSTRUCTIONS TO BIDDERS**

## **SPECIAL INSTRUCTIONS TO BIDDERS**

- 13.1 Before tendering, the tenderer shall visit all the Speed Violation Detection System Locations, Traffic Police HQ, Worli, BMC Control Room at Worli of BMC & satisfy himself as to the prevailing conditions. In case of doubt, the bidders may obtain the required information from Ex. Eng. (ATC), which may not in any way influence the tender, as no claim what-so-ever shall be entertained for any alleged ignorance, after the opening of tender.
- 13.2 The tenderers are directed to go through the entire Tender document including directions / specifications, etc. and get the clarifications, if any, before filling up of the tender. Such requests regarding clarifications, if any shall be in writing and shall reach the office of Ex. Eng. (Area Traffic control) / Dy.Ch.E. (Traffic) at least 7 days prior to due date of the tender.
- 13.3 Wherever the word quotation / quotationer or bid or bidders is appeared, it should be read as Tender / Tenderer.
- 13.4 The successful contractor will have to pay the legal & stationery charges as per the prevailing norms of BMC at the time of contract execution.
- 13.5 Time is the essence of the contract.
- 13.6 No price escalation will be payable.
- 13.7 For procured material, if no space is available on site then tenderer shall make his own arrangement for stacking of material. No extra payment will be made on this account. The entire work shall be done without causing any inconvenience to others.
- 13.8 The contract period is 24 months (Inclusive of monsoon). The contract period is inclusive of period required for mobilization, procurement of material.
- 13.9 The tenderer shall submit the schedule showing all the activities logically within the contract period in a mutually accepted manner & shall have to be made available from time to time in the office of Ex. Engineer (Area Traffic Control).
- 13.10 Tenderer shall have to obtain all the permission of the concerned authorities / other agencies required for carrying out the work on their own, only recommendatory letters will be issued by B.M.C.
- 13.11 The successful tenderer(s) shall provide various cautionary / safety boards on site while working.
- 13.12 The contractor will have to carry out the work either during daytime and / or night time as feasible to various site conditions with the assistance of concerned Traffic division personnels.
- 13.13 The whole work shall be finished in workman like manner and to the entire satisfaction of the Municipal Commissioner. The entire work shall be in accordance with the latest modern practice and shall present a neat appearance when completed from aesthetic point of view.
- 13.14 Compliance of Rules: All works shall be carried out in accordance with the latest rules under the Indian Electricity Act, 1910 as applicable. The contractor shall comply strictly to Indian Standards Institution Code (IS 732-1950) of practice for Electrical wiring and fittings in Buildings. Installation shall comply

with all the laws and regulations in effect with the regulations of the Competent authorities and the requirement of the Government and the Electric Supply Company's.

- 13.15 The specifications included in the tender follows corresponding to IRC, IS/BIS/EN or any relevant standard. In case of any contradiction in specification, the decision of Engineer will be final and binding.
- 13.16 All General conditions for different works i.e. electrical, mechanical, civil etc, as stipulated by the BMC from time to time, as amended upto date shall be applicable to the contract.
- 13.17 Contract Labour (Regulation and Abolition act 1970): The Bidder should specifically note that the successful Bidder shall have to strictly comply with all the statutory requirements under the provision of the Contract Labour (Regulation and Abolition) Act, 1970 and with the Maharashtra State Contract Labour (Regulation and Abolition) Rules 1971 and indemnify the Corporation against any claim(s) whatsoever.
- 13.18 Tenderers are requested to take cognizance of child Labour Act and take precaution not to deploy child Labourers on site. If Child Labourer is found to be deployed on the work, necessary action as deemed fit will be taken.
- 13.19 The contractors shall adhere / abide themselves by the provision of the minimum wages act / Workman compensation Act and such other statutory obligations notified by the concerned Government departments from time to time. They shall also indemnify the BMC from any claims whatsoever arising there from and shall be solely responsible for consequences thereof
- 13.20 Tenderer shall be registered under the Goods & Service Tax (GST) under GST Act 2017 and shall produce documentary evidence to that effect (a copy of registration of certificate from the Goods & Service Tax department) along with tender.
- 13.21 BMC reserves right to cancel the individual works at any stage and tenderers will not be entitled to any compensation / claims whatsoever on account of such cancellation.
- 13.22 BMC is not bound to accept the lowest or any Tender and they reserve the right to relax any of the stipulated conditions and reject any or all Tenders, without assigning any reason.
- 13.23 Previous bad / good records of Tenderers and also their previous experience in major cities in India shall be considered while evaluating the tender.
- 13.24 Rate analysis indicating the justifiability of the rates quoted by the tenderer for satisfactory execution and completion of the work, shall be submitted by the tenderer as and when directed by Engineer.
- 13.25 The rates quoted by the tenderer shall be firm and inclusive of delivery of materials at site. Separate transportation charges will not be paid by BMC.
- 13.26 Tenderer should specifically state their official addresses along with the telephone and mobile number. The contractor or their partners and authorized representative shall be available on a given telephone number during any hours of the day.

- 13.27 Firms with common proprietors / partner or connected with one another either financially or as Principal agent or as master and servant or with Proprietor / Partners closely related to each other such as husband / wife / father / mother and minor son / daughter and brother / sister and minor brother / sister shall not tender separately under the different names for the same contract.
- 13.28 If it is found that firms as described vide Clause 13.27 above, have tendered separately under different names for the same contract, all such tender shall stand rejected and tenderer(s) EMD (Earnest Money Deposit) shall be forfeited. Any contract entered into under such conditions will also be liable to be cancelled at any time during its currency and penal action including blacklisting of such firms will be taken.
- 13.29 All the details regarding the staff proposed shall be approved and if any change in that regard shall be immediately intimated to the office. Name and Bio-data of the technically qualified personnel employed to supervise the work should be intimated to the Engineer before starting of the work.
- 13.30 The work will be treated as completed only after cleaning the site in all respect after completion of the work and to the satisfaction of the Engineer.
- 13.31 The items supplied and installed under this contract should be guaranteed for satisfactory performance during the entire contract period. However, the guarantee obligation is limited to defects during normal course of operation and damage / defects due to accidents, thefts, vandalism, mob fury, pandemic situation and other force major conditions are not covered under guarantee.
- 13.32 The successful tenderer will have to make their own arrangements for spare parts/ accessories at their cost, wherever necessary.
- 13.33 The maintenance contractor shall hand over the entire system under their maintenance contract in working condition to the agency as and when appointed by B.M.C. in future.
- 13.34 It will be the sole responsibility of the contractor to provide new power supply connection / extending existing power supply if necessary under this contract. The BMC will provide only the required letters to the power supply authorities. The monthly energy charges for all location shall be borne by BMC.
- 13.35 Successful Tenderers shall submit test certificates of all the supplied materials.
- 13.36 If it is observed that the contractors carrying out the work, fails to comply with the instructions given by the higher Authorities at A.M.C. / M.C. level during execution of work twice, the work will be terminated and will be carried out at the risk and cost of the contractor and penal action will be taken against them. This decision will not be arbitral at all.
- 13.37 The tenderers shall note that whenever the Engineer gives order in writing to carry out any work/ works of similar nature covered in the contract in any adjacent area, they shall be bound to carry out the additional work/works treating them as work / works under contract conditions. The additional works so specified shall be carried out at the same rate quoted and within the given time frame only.
- 13.38 The BMC in this contract is the Employer and Executive Engineer (ATC) is the Engineer for this contract. The Engineer or his representative will strictly su-

pervise the work at all levels. The contractor shall submit the test certificates and shall observe strict adherence to the given standards unless, otherwise specified in writing by competent authority is expected. Any deviation from the given standards will not be tolerated.

- 13.39 Departure from Specifications: Should the Tenderer wish to depart from the provisions of the specifications or general conditions of contract, he shall clearly mention them giving his reasons thereof. Unless this is done, the equipment offered and work executed shall be deemed to comply in every respect with the terms and conditions of the specifications without claiming any extra charges whatsoever.
- 13.40 If a particular work is delayed inordinately, the same work will be got executed from some another agency at the risk & cost of the contractor.
- 13.41 The payment of the bills and other claims arising out of the contract will be made in the name of tenderer's Bank by E.C.S/RTGS only. Successful tenderer therefore will have to furnish information as regards the name and complete address of his bank, its branch and the bank A/c no & E.C.S. No. etc. along-with tender document. They will have also to submit updated information when there is any change in this regard.
- 13.42 The contractors shall comply with the inter utility organizations and code of conduct wherever such applies to the conduct of this contract.
- 13.43 The contractor shall make an alternate arrangement of staff in the absence of regular staff deputed for the work.
- 13.44 If any item which is outdated at the time of executing the tender, then higher version compatible with existing item shall be provided. No extra cost will be paid.
- 13.45 It is to clarify that all BOQ items may not be executed as mentioned in the tender. The items will operated as per Engineer's instruction.
- 13.46 If at any time after acceptance of the tender the Commissioner shall decide to abandon or reduce the scope of the works or any part of the works to be carried out, he shall inform the Contractor in writing one month notice prior to that effect and the Contractor shall have no claim to any payment or compensation.
- 13.47 The Standard General condition of contract for Construction Work 2016 is applicable for this contract.
- 13.48 The successful bidder shall make use of the removed/retrieved reusable materials, wherever possible under this contract. The rebate of 2% amount of removed item which is unusable shall be deducted as a salvage cost as per USOR-2023 rate. The scrap material will be the property of the contractor
- 13.49 All the new procured cameras shall have minimum 2 years of Original Equipment Manufacturer's (OEM) warranty and any defect/ lapses observed shall be rectified by the OEM at his own cost, without any financial implication to BMC during warranty period. Further, it is sole responsibility of the contractor to coordinate with OEM to get proper services for the procured material / equipments/technical support.

- 13.50 Working at Height: The work is carried out at height, hence special attention shall be given to work at height. The ladder of sufficient height or Mac-Lifton shall be used. The required care as described in the Indian safety Rules shall be strictly adhered. If any accident or Mishap happen due to any reason the contractor will be held solely responsible for the same. The Employer will not be responsible to any such untoward incidents arise from the negligence or improper method or lack of safety procedures.
- 13.51 Use of Personal Protective Equipments: The contractor shall ensure that all the protective equipments are given to the employees working on site. The contractor will be held solely responsible for any negligence on this part.
- 13.52 Working on Site: The civil work as well as mechanical work is carried out on the site. The Site shall be properly barricaded by the FRP barricades. The blinkers shall be provided on the ends and at the turning to visualize the on going work to the road users. The illuminated batten shall be used during night hours to control the traffic. The workers working on the site shall wear the reflective jackets during the working hours. The road safety norms of BMC for work on site shall be strictly followed. The display boards shall be provided on site with following details – Go Slow - work in progress, inconvenience caused is regretted, use the diversion, name of the contractor etc. The supervisor in-charge of the site shall issue the work permit to the staff on working after satisfying the safe conditions on site for work.
- 13.53 Adequate precaution shall be taken to prevent danger from electrical equipment. No materials on any of the sites shall be so stacked or places as to cause danger or inconvenience to any person or the public.
- 13.54 Adequate provision made for prompt first aid treatment of all injuries likely to be sustained during the course of the work.
- 13.55 While carrying out Speed test, the necessary all precautionary safety measures shall be taken on site to avoid any mishap, accidents, etc. The Employer will not be responsible to any such untoward incidents arise from the negligence or improper method or lack of safety procedures.

# **SECTION 14**

## **APPENDIX & PROFORMAS**

**FORM OF TENDER**

To,  
The Municipal Commissioner for Brihanmumbai

Sir,

I/ We have read and examined the following documents relating to the work of.....  
.....  
.....

- i. Notice inviting tender.
- ii. Directions to tenderers (General and special)
- iii. General condition of contract for Civil Works of the Brihanmumbai Municipal Corporation as amended up to date.
- iv. Relevant drawings
- v. Specifications
- vi. Special directions
- vii. Annexures
- viii. Bill of Quantities and Rates

1A. I/  
We.....

(full name in capital letters, starting with surname), the Proprietor/ Managing Partner/ Managing Director/ Holder of the Business, for the establishment / firm / registered company, named herein below, do hereby offer to  
.....  
.....  
.....  
.....

Referred to in the specifications and schedule to the accompanying form of contract of the rates entered in the schedule of rates sent herewith and signed by me/ us" (strike out the portions which are not applicable).

1B. I/We do hereby state and declare that I/We, whose names are given herein below in details with the addresses, have not filled in this tender under any other name or under the name of any other establishment /firm or otherwise, nor are we in any way related or concerned with the establishment /firm or any other person, who have filled in the tender for the aforesaid work."

2. I/We hereby tender for the execution of the works referred to in the aforesaid documents, upon the terms and conditions, contained or referred to therein and in accordance with the specifications designs, drawings and other relevant details in all respects.

- At the rates entered in the aforesaid Bill of Quantities and Rates.

3. According to your requirements for payment of Earnest Money amounting to Rs. ..../- (Rs. ....)

I/We have deposited the amount through online payment gateways with the C.E. of the Corporation not to bear interest

4. I/We hereby request you not to enter into a contract with any other person/s for the execution of the works until notice of non/acceptance of this tender has first been communicated to me/us, and in consideration of yours agreeing to refrain from so doing I/we agree not to withdraw the offer constituted by this tender before the date of communication to me/us of such notice of non/acceptance, which date shall be not later than ten days from the date of the decision of the Standing Committee or Education Committee of the Corporation, as maybe required under the Mumbai Municipal Corporation Act, not to accept this tender.(Subject to condition 5 below).

5. I/We also agree to keep this tender open for acceptance for a period of 180 days from the date fixed for opening the same and not to make any modifications in its terms and conditions which are not acceptable to the Corporation.

6. I/We agree that the Corporation shall, without prejudice to any other right or remedy, be at liberty to forfeit the said earnest money absolutely, if.

- a. I/We fail to keep the tender open as aforesaid.
- b. I/We fail to execute the formal contract or make the contract deposit when called upon to do so.
- c. I/we do not commence the work on or before the date specified by the Engineer in his work order.

7. I/We hereby further agree to pay all the charges of whatsoever nature in connection with the preparation, stamping and execution of the said contract.

8. I/We further agree that, I/we shall register ourselves as 'Employer' with the Bombay Iron and Steel Labour Board' and fulfill all the obligatory provisions of Maharashtra Mathadi, Hamal and other Manual workers (Regulation of Employment and Welfare) Act 1969 and the Bombay Iron and Steel unprotected workers Scheme 1970.

9. "I/We..... have failed in the accompanying tender with full knowledge of liabilities and, therefore, we will not raise any objection or dispute in any manner relating to any action, including forfeiture of deposit and blacklisting, for giving any information, which is found to be incorrect and against the instructions and directions given in this tender.

10. "I/We further agree and undertake that in the event it is revealed subsequently after the allotment of work/contract to me/us, that any information given by me/us in this tender is false or incorrect, I/We shall compensate the Brihanmumbai Municipal Corporation for any such losses or inconvenience caused to the Corporation in any manner and will not resist any claim for such compensation on any ground whatsoever. I/we agree and undertake that I/we shall not claim in such case any amount by way of damages or compensation for cancellation of the contract given to me/us or any work assigned to me/us or is with-drawn by the Corporation,"

Address

.....  
.....

Yours faithfully,

Digital Signature of the  
Tenderer or the Firm

- 1.....
- 2.....
- 3.....
- 4.....
- 5.....

Full Name and private residential address of  
all the partners constituting the Firm

- |    |       |                         |
|----|-------|-------------------------|
| 1. | ..... | A/c No. ....            |
| 2. | ..... | Name of Bank<br>.....   |
| 3. | ..... | Name of Branch<br>..... |
| 4. | ..... | Vender No.....          |
| 5. | ..... |                         |

## AGREEMENT FORM

Tender No ..... dated .....

Standing Committee/Education Committee Resolution No. ....dated.....

CONTRACT FOR THE WORKS".....

....."

This agreement made this day of ..... Two thousand .....

Between .....

inhabitants of Mumbai, carrying on business at .....

in Mumbai under the style and name of Messrs.....

..... (Hereinafter called "the contractor of the one part and Shri .....

the Director(E.S.& P.)/D.M.C. (Infrastructure) (hereinafter called "the commissioner" in which expression are included unless the inclusion is inconsistent with the context,

or meaning thereof, his successor or successors for the time being holding the office of Director (E.S.& P.) /D.M.C. (Infrastructure) of the second part and the Brihanmum-

bai Municipal Corporation (hereinafter called "the Corporation") of the third part, WHEREAS the contractor has tendered for the construction, completion and maintenance of the works described above and his tender has been accepted by the

Commissioner (with the approval of the Standing Committee/Education Committee of the Corporation

the Corporation

NOW THIS AGREEMENT WITNESSETH as follows:-

- 1) In this agreement words and expressions shall have the same meanings as are respectively assigned to them in the General Conditions of Contract for works hereinafter referred to:-
- 2) The following documents shall be deemed to form and be read and constructed as a part of this agreement viz.
  - a) The letter of Acceptance
  - b) The Bid:
  - c) Addendum to Bid; if any
  - d) Tender Document
  - e) The Bill of Quantities:
  - f) The Specification:
  - g) Detailed Engineering Drawings
  - h) Standard General Conditions of Contracts (GCC)
  - i) All correspondence documents between bidder and BMC

- 3) In consideration of the payments to be made by the Commissioner to the contractor as hereinafter mentioned the contractor hereby covenants with the Commissioner to construct, complete and maintain the works in conformity in all respects with the provision of the contract.
- 4) The Commissioner hereby covenants to pay to the Contractor in consideration of the construction, completion and maintenance of the works the contract sum, at times and in the manner prescribed by the contract.

IN WITNESS WHERE OF the parties hereto have caused their respective common seals to be herein to affixed (or have hereunto set their respective hands and seals) the day and year above written.

Signed with designation stamp  
of the contractor, Sealed and  
delivered by the contractors)

Seal

Trading under the name & style of )

-----  
-----  
-----

In the presence of witness

Witness No. 1: Name & Address

Name: .....

Resi Address:.....

..... Signature of Witness No. 1

Witness No. 2: Name & Address

Name: .....

Resi Address:.....

..... Signature of Witness No. 2

Signed by the Director (E.S.& P.) /D.M.C.(Infrastruc-  
ture) in the presence of

1.  
.....

2. Director(E.S.& P.)/

.....

D.M.C.(Infrastructure)

Name and Signature of concern Dy.Ch.Eng. & Ch.Eng. (HOD) with Designation Stamp

Dy.Ch.Engr.  
(Traffic)

Ch.Eng.  
(Roads & Traffic)

Shri/Smt.....

Shri/Smt.....

.....

.....

The Common seal of the Brihanmumbai Municipal Corporation was affixed on the day of .....20..... presence of

1. ....

2. ....

Two members of the Standing Committee of the Brihanmumbai Municipal Corporation.

Witness:

(Shri/Smt.....)

Office Superintendent,  
Municipal Secretary's Office

## ANNEXURE A

1. The Engineer for this works:      Ex. Engr.(ATC)

2. The Estimated Cost of the Tender:      Rs. 1,30,02,826/-

<b>Sr No</b>	<b>Description of work</b>	<b>Total Amount Rs.</b>
1	Civil Work	<b>NA</b>
2	Electrical Work	1,30,02,826.00
3	Total Amount	1,30,02,826.00

3. Earnest Money (1% of the Estimated cost):Rs. 1,30,100/-

4. Time Period: 24 months inclusive of monsoon.

Contract as a whole Period completion	
Part or Groups of items	
i)	i)
ii)	ii)
iii)	iii)

5. Percentage to be charged as supervision charges for the work got executed through other means .....percent.
6. The "Actual cost of the work" shall mean in the case of percentage rate contracts the actual cost of the work executed at the rates as mentioned in the Contract Schedule adjusted by the Contractor's percentage rate and cost of extra and excess, but excluding the cost on account of Water Charges and Sewerage Charges if any, payable by the contractor and also excluding cost on account of price variation claims as provided in price variation clause as amended up to date.
7. In case of item rate contracts the actual cost calculated for the work executed at the rates mentioned in the contract schedule for different items including cost of excess and extra items of the work excluding the cost of water charges and sewerage charges if any, payable by the contractor and excluding cost on

account of price variation claims as provided in extra excess conditions as amended up to date.

8. In case of lump sum contract the cost of the work actually carried out as per break up and programme of the work and the schedule of payment included in the contract including cost of any excess and/or extra items, of the work, excluding the cost on account of water charges and sewerage charges and also excluding cost on account of price variation claims as provided in extra excess conditions as amended up to date.

Signature of the Tenderer of the Firm

## **Annexure- B**

### **PRE-CONTRACT INTEGRITY PACT**

(On Rs. 500/- Stamp Paper)

The Bidder commits himself to take all measures necessary to prevent corrupt practices, unfair means and illegal activities during any stage of his bid or during any pre-contract or post-contract stage in order to secure the contract or in furtherance to secure it and in particular commits himself to the following:-

1. The Bidder will not offer, directly or through intermediaries, any bribe, gift, consideration, reward, favour, any material or immaterial benefit or other advantage, commission, fees, brokerage or inducement to any official of the BMC, connected directly or indirectly with the bidding process, or to any person, organization or third party related to the contract in exchange for any advantage in the bidding, evaluation, contracting and implementation of the Contract.
2. The Bidder further undertakes that he has not given, offered or promised to give, directly or indirectly any bribe, gift, consideration, reward, favour, any material or immaterial benefit or other advantage, commission, fees, brokerage or inducement to any official of the BMC or otherwise in procuring the Contract or forbearing to do or having done any act in relation to the obtaining or execution of the Contract or any other Contract with the Government for showing or forbearing to show favour or disfavour to any person in relation to the Contract or any other Contract with the Government.
3. The Bidder will not collude with other parties interested in the contract to impair the transparency, fairness and progress of the bidding process, bid evaluation, contracting and implementation of the contract.
4. The Bidder will not accept any advantage in exchange for any corrupt practice, unfair means and illegal activities.
5. The Bidder, either while presenting the bid or during pre-contract negotiations or before signing the contract, shall disclose any payments he has made, is committed to or intends to make to officials of the BMC or their family members, agents, brokers or any other intermediaries in connection with the contract and the details of services agreed upon for such payments.
6. The Bidder shall not use improperly, for purposes of competition or personal gain, or pass on to others, any information provided by the BMC as part of the business relationship, regarding plans, technical proposals and business details, including information contained in any electronic data carrier. The Bidder also undertakes to exercise due and adequate care lest any such information is divulged.
7. The Bidder commits to refrain from giving any complaint directly or through any other manner without supporting it with full and verifiable facts.

8. The Bidder shall not instigate or cause to instigate any third person to commit any of the actions mentioned above.
9. The Bidder and their respective officers, employees, agents and advisers shall observe the highest standard of ethics during the Bidding Process. Notwithstanding anything to the contrary contained herein, the Authority may reject bid without being liable in any manner whatsoever to the bidder if it determines that the bidder has, directly or indirectly or through an agent, engaged in corrupt practice, fraudulent practice, coercive practice, undesirable practice or restrictive practice in the Bidding Process.

For the purposes of this Clause 9, the following terms shall have the meaning herein after respectively assigned to them:

1. "fraudulent practice" means a misrepresentation or omission of facts or suppression of facts or disclosure of incomplete facts, in order to influence the Bidding Process;
2. "coercive practice" means impairing or harming or threatening to impair or harm, directly or indirectly, any person or property to influence any persons participation or action in the Bidding Process;
3. "undesirable practice" means (i) establishing contact with any person connected with or employed or engaged by the Authority with the objective of canvassing, lobbying or in any manner influencing or attempting to influence the Bidding Process; or (ii) having a Conflict of Interest; and
4. "restrictive practice" means forming a cartel or arriving at any understanding or arrangement among bidders with the objective of restricting or manipulating a full and fair competition in the Bidding Process.

Signature of Tenderer/Bidder

## **Annexure- C**

(On Rs. 500/- Stamp Paper)

### **DECLARATION CUM INDEMNITY BOND**

I, \_\_\_\_\_ of \_\_\_\_\_, do hereby declared and undertake as under.

1. I declare that I have submitted certificates as required to Executive engineer (Monitoring) at the time of registration of my firm/company \_\_\_\_\_ and there is no change in the contents of the certificates that are submitted at the time of registration.
2. I declare that I \_\_\_\_\_ in capacity as Manager/Director/Partners/Proprietors of \_\_\_\_\_ has not been charged with any prohibitory and /or penal action such as banning(for specific time or permanent)/de-registration or any other action under the law by any Government and/or Semi Government and/or Government undertaking.
3. I declare that I have perused and examined the tender document including addendum, condition of contract, specifications, drawings, bill of quantity etc. forming part of tender and accordingly, I submit my offer to execute the work as per tender documents at the rates quoted by me in capacity as \_\_\_\_\_ of \_\_\_\_\_.
4. I further declare that if I am allotted the work and I failed to carry out the allotted work in accordance with the terms and conditions and within the time prescribed and specified, BMC is entitled to carry out the work allotted to me by any other means at my risk and cost, at any stage of the contract.
5. I also declare that I will not claim any charge/damages/compensation for non availability of site for the contract work at any time.
6. I declare that I will positively make the arrangements of the required equipment on the day of commencement or with respect to the progress of the work in phases, as per the instructions of site in charge

Signature of Tenderer/Bidder

**Annexure -E**

**Irrevocable Undertaking**

(on Rs. 500/- Stamp paper)

I Shri/Smt ..... aged, ..... years  
Indian Inhabitant. Proprietor/Partner/Director of M/s. .... resident  
at .....  
.....  
do hereby give Irrevocable undertaking as under;

- 1) I say & undertake that as specified in section 171 of CGST Act, 2017, any reduction in rate of tax on supply of goods or services or the benefit of input tax credit shall be mandatorily passed on to BMC by way of commensurate reduction in prices.
- 2) I further say and undertake that I understand that in case the same is not passed on and is discovered at any later stage, BMC shall be at liberty to initiate legal action against me for its recovery including, but not limited to, an appeal to the screening Committee of the GST Counsel.
- 3) I say that above said irrevocable undertaking is binding upon me/my partners/company/other Directors of the company and also upon my/ our legal heirs, assignee, Executor, administrator etc.
- 4) If I fail to compliance with the provision of the GST Act, I shall be liable for penalty/punishment or both as per the provisions of GST Act.

Whatever has been stated here in above is true & correct to my / our own knowledge & belief.

Solemnly affirmed at

DEPONENT

This day of

BEFORE ME

Interpreted Explained and Identified by me.

**ANNEXURE F**  
**TECHNICAL DATA SHEET**

The bidder shall submit the relevant/supporting documents as specified in Technical Data sheet with Annexure-F

**Item 1: R3-RT-ATC 11.17 Automatic Number Plate Recognition Camera (The Camera with higher technical specification will be acceptable).**

<b>Sr. No.</b>	<b>Description</b>	<b>Specification</b>	<b>Compliance</b>
1	Image Sensor	1/2.8" 1080p CMOS	
2	Effective Pixels	1920 x 1080	
3	Scanning System	Progressive scanning	
4	AGC Control	Auto, adjustable amplification level	
5	Auto IRIS (DC)	Iris control via camera unit	
6	Minimum Illumination	Color: 0.2Lux / 0.01Lux (DSS On) B/W : 0 Lux (IR LED On)	
7	Lens	2.8(w) – 12.0mm(t), F1.4(w) – F2.6(t), Motorized Focus & Zoom Control – One Click Focus Function	
8	Angle of View	Horizontal: Approx. 99°(Wide) to 35°(Tele) Vertical: Approx. 54°(Wide) to 20°(Tele)	
9	Day & Night Switching	Auto/Manual (both switching level adjustable 1 ~ 64) removable IR Cut Filter	
10	Image Settings	Configurable brightness, contrast, saturation, sharpness, vertical flip & horizontal mirror function, Corridor Mode (-90° / +90° image flip)	
11	Wide Dynamic Range	Up to >80dB Dynamic Range with activated WDR	
12	Backlight Compensation	BLC On/Off (possible to designate zone)	

13	IR ILLUMINATOR	IR LED High Power IR LED x 16 (850nm) IR Working Distance up to 35m (115ft)	
14	Video Compression	H.264 Baseline, Main, High profile (MPEG-4 Part 10/ AVC), MJPEG (Motion JPEG)	
15	Resolutions 16:9 mode	1920x1080, 1280x720, 1120x630, 960x540, 800x450, 640x360, 480x270, 320x180	
16	4:3 mode	SXGA(1280x960), XGA(1024x768), SVGA (800x600), PAL(720x576), NTSC(720x480) VGA(620x480), QVGA(320x240)	
17	Frame Rate	H.264: Configurable up to max 30fps in all resolution MJPEG: Configurable up to max 30fps in all resolution	
18	Motion Detection	Max. 8 zones with independent configuration of detection sensitivity and target object size	
19	Privacy Mask Zones	4 flexible configurable regions	
20	Analogue Video	NTSC/PAL Video Signal (1.0Vp-p, 75Ω)	
21	Ethernet Standard/IP	10 / 100 Base-T / IPv4, IPv6	
22	Protocol	QoS Layer 3 DiffServ, TCP/IP, UDP/IP, HTTP, HTTPS, FTP, RTSP, RTCP, RTP/UDP, RTP/TCP, mDNS, UPnP™, SMTP, DHCP, DNS, DynDNS, NTP, SNMPv1/v2c/v3(MIB-II), IGMP, ICMP, SSLv2/v3, TLSv1, SRTP, RTMP	
23	Users Connection	Live viewing for up to 10 clients Security HTTPS(SSL),	

		IP Filtering, Multi-level access with password protection NERAL	
24	I/O Terminal	1x Alarm In - max 50mA@5VDC, TTL 1x Alarm Out - max 50mA@24VDC, TTL	
25	Edge Storage	Via micro SD/SDHC (up to 32GB) card for continuous or event recording. Search interface for event files, playback and download (card not included).	
26	Application Programming Interface	Software Development Kit (SDK) available	
27	Event Metadata	Streaming RTSP/RTP Video Motion Detection(MD), Video Content Analytics(VCA)	
28	ONVIF Version	2.41 (Support Profile S and G)	
29	Event Sources	Sensor(DI), Video Motion Detection, Tamper Detection, Video Content Analytics(VCA),	
30	Detection	Zones and Rules Up to 40 zones (multi-segment polygons and lines) 60 VCA filter rules in total	
31	Tamper Detection	Recognize camera tampering via VCA detection (defocusing, lens covering, camera moving)	
32	Available License	VCAdetectIP, VCAcountIP, VCAadvancedIP, VCAprofessionalIP	
33	VCA Detection Filters Object:	Enter, Exit, Appear, Disappear, Stop, Direction, Dwell, Speed, Unauthorized Access, Counting Line, Color Filter, Object Classification	

**Item 2: R3-RT-ATC 11.18.A Supply of certified 4D HD Radar** (Speed sensor) in compliance to legal metrology norms for speed enforcement upto 320 km/hr. The sensor should be able to cover up to 6 lanes and able to track a minimum 64 vehicles simultaneously. The speed accuracy should be as per OIML R 91 regulations. The sensor should also be certified for use in the proposed speed system with legal metrology standards for speed fines.

<b>Sr. No.</b>	<b>Description</b>	<b>Specification</b>	<b>Compliance</b>
1	Radar Type	4D HD	
2	Capability	Shall be capable of covering of 6 lane	
3	Detection Targets	1. Four wheelers (Car, Trucks, Buses) 2. Three wheelers 3. Two Wheelers (Scooter/Motor Cycle)	
4	Detection Range	1. Minimum Range at least 20 m 2. Max Range Passenger car-140 m Truck- 180 m	
5	Speed Range	30 kmph (or lower desirable) and 250 kmph	
6	Speed accuracy	<+/- 0.28 m/s +/-1% (bigger of)	
7	Tracking	Simultaneously able to track at least 64 objects	
8	Azimuth FOV	Azimuth Angle: -50....+50°)	
9	Form Factor	Enclosed Rugged, Watertight Casing (Metal/Polycarbonate (UV Stabilized) Pole Mount.	
10	IP Protection	IP 66 or Better	
11	Operating Temperature	-40 to +80 degree	
12	Shock	100grms	
13	Vibration	14grms	
14	Frequency Band	EIRP 24.0 to 24.25 GHz (K Band) better than 20dBm	

15	Input Power	12 to 32 VDC : 5.0 Watts	
16	Serial	Communication Interface RS485	
17	Ethernet	Compatible interface modules Ethernet	
18	Simulator Interface	Windows, Linux	
19	Testing	Testing report for accuracy of speed measurement from an approved Govt. Body/Govt. Lab or by any Govt. R&D organization in India or any international certifying agencies / independent certification authorities from the country of origin. The test report from ARAI (Automotive research association of India) or OIML R 91 shall also suffice the requirement of speed accuracy of Radar	
20	Certifications	CE/EN, FCC, NEMA	

**Item No. 3: R3-RT-ATC 11.19.A Additional illuminator for ANPR**

<b>Sr. No.</b>	<b>Description</b>	<b>Specification</b>	<b>Compliance</b>
1	Type	IR illuminator 780 nm/ 850 nm/930 nm	
2	Illumination Range	15 to 20 feet	
3	Environment Protection	IP67	

**Item No.4: R3-RT-ATC 11.21.A Road side processing unit with Processor, storage, communication modem, battery charger, watch dog module and IP66 casing, cabling, mounting brackets and fixtures**

<b>Sr. No.</b>	<b>Description</b>	<b>Specification</b>	<b>Compliance</b>
1	Type of Road Site Processing Unit	Industrial grade	
2	Capability of processing	The Road Side Processing Unit should be capable of processing of data for 8 ANPR Cameras for Instant Speed Detec-	

		tion	
3	Network Connectivity	Wireless technology for real time transfer of data to the Traffic Police Control Room	
4	Port availability	Minimum 2 USB port to support the latest Mass Storage Devices and Ethernet port for possible networking. However, all logs of data transfer through the ports shall be maintained by the system.	
5	Temperature range	ambient temperature range of -5 to 60 degree.	
6	UPS capability	UPS of appropriate rating having atleast 3 hours power back up to keep the junction functional.	
7	Additional features	The system should automatically be re settable in the event of a program hang up and restart on a button press. However, the system should start automatically after power restoration in the event of a power failure.	
8	Additional features	The system should have secure access mechanism for validation/editing of authorised personnel.	
9	Additional features	All formats of store data should be user friendly to extract the data from Road Side Processing Unit and should have activity log and data protection mechanism.	
10	Additional features	The system should be able to transfer data to Control Room through proper encryption in real time and batch mode for further action including verification of the infraction and processing of challan.	

11	Additional features	In the event that the connectivity at control room is not established then all data pertaining to infraction shall be stored on site and will be transfer once the connectivity is re-stored.	
12	Additional features	It should be facilitate physical transfer of data on portable storage device I.e Laptop, notebook, portable harddisk etc. whenever required with secure authentication process in the software.	

If the bidder wish to supply the material other than the existing model then, the bidder shall make sure that the material supplied shall be compatible and properly integrated to the existing system. The bidder shall fulfilled the specification in the Technical data sheet for the items mentioned above and shall arrange Proof of Concept (POC) of the above said items within 15 Days as instructed by Engineer. The bidders who fulfil the POC shall be qualified for opening of Packet 'C'. The bidders who fails to give POC within prescribed time limit shall be treated as Non Responsive and their Packet C shall not be opened. The 10% EMD will be forfeited of Non Responsive bidder."

## ANNEXURE D

### Rate Analysis

Item Description:					
Sr. No.	Description of Rate Analysis Parameters	Unit	Quantity	Rate	Amount
1	Basic Material (Rate should be inclusive of all taxes other than GST (Excluding GST), levies, duties, cess etc.)				
2	Machinery Hire Charges				
3	Labour Type		(labour components)		
4	Total of all components				
5	Overhead & Profit 15% on 4				
6	Total Rate (4+5)				
7	Per unit rate				

Sign & Seal of the Bidder/Tenderer

PROFORMAS:  
**PROFORMA-I**

The list of similar works as stated in Eligibility Criteria during last seven years-

Sr. No.	Name of the Project	Name of the employer	Stipulated date of completion	Actual date of completion	Actual Cost of work done
1	2	3	4	5	6
1					
2					
3					
4					
5					

**NOTE:**

Scanned self Attested copies of completion/performance certificates from the Engineer-in-Charge and Documents mentioning in all above information for each work should be annexed in the support of information furnished in the above proforma. Works shall be grouped financial year-wise.

Sign & Seal of the Bidder/Tenderer

## PROFORMA-II

Annual turnover of Works during the last five years.

Sr. No.	Financial year	Annual Turnover of Works	Updated value to current year FY 2023-24	Average of last 3 years	Page No.
(a)	(b)	(c)	(d)	(e)	(f)
1	2017-18				
2	2018-19				
3	2019-20				
4	2020-21				
5	2021-22				
Total					

**NOTE:**

I) The above figures shall tally with the audited balance sheets uploaded by the tenderers duly certified by Chartered Accountant.

II) Updated Value to current value shall be updated to the price level of the Financial year in which bids are received at a rate of 10% per year.

Sign & Seal of the Bidder/Tenderer

### PROFORMA-III

Details of similar works as stated in Eligibility Criteria during last Seven years.

Name of the Project	Name of the Employer	Cost of the Project	Date of issue of work Order	Stipulated Date of Completion	Actual Date of Completion	Actual cost of work done	Remarks explaining reasons for delay, if any
1	2	3	4	5	6	7	8

**Note:** Scanned self Attested copies of completion/performance certificates from the Engineer-in-charge and document mentioning in all above information for each work should be annexed in support of information furnished in the above proforma.

Sign & Seal of the Bidder/Tenderer

**PROFORMA-IV**  
**Technical Personnel (as per clause 6.9)**

<b>Sr. no.</b>	<b>Post</b>	<b>Name</b>	<b>Qualification</b>	<b>Experience</b>
1				
2				
3				

**NOTE:** Scanned self Attested copies of qualification certificates and details of work experience shall be submitted /uploaded.

Sign & Seal of the Bidder/Tenderer

**PROFORMA-V**

Machinery: (for special work only)

**NOT APPLICABLE**

## PROFORMA-VI/A

Details of Existing Commitments and ongoing works –

Description of work	Place	Contract No. & Date	Name & Addresses of employer	Value of Contract in Rs.	Scheduled date of completion	Value of work remaining to be completed	Anticipated Date of completion
1	2	3	4	5	6	7	8

**Note:** Scanned self Attested copies of completion/performance certificates from the Engineer-in-Charge and documents mentioning in all above information for each work should be annexed in the support of information furnished in the above proforma.

Sign & Seal of the Bidder/Tenderer

## PROFORMA-VI/B

Details of works for which bids are already uploaded –

Description of work	Place	Name & Addresses of employee	Value of Contract in Rs.	Time Period	Date on which decision is expected	Remarks
1	2	3	4	5	6	7

**Note:** Scanned self Attested copies of certificates from the Engineer-in-charge and Document mentioning all above information for each work shall be annexed.

Sign & Seal of the Bidder/Tenderer

**PROFORMA-VII**  
**AFFIDAVIT FOR BEST PRICE**

**Tender No.** \_\_\_\_\_

To,  
The Municipal Commissioner,  
For the Brihanmumbai Municipal Corporation

Sir,

Bid No.....

"I / We .....  
(Full name in capital letters, starting with surname), the Proprietor / Managing Partner / Managing Director / Holder of the Business / Manufacturer / Authorized Dealer, for the establishment / firm / registered company, named herein below, do hereby, state and declare that I/We ..... whose names are given herein below details with addresses have not filled in this tender under any other name or under name of any other establishment / firm otherwise, nor are we in any way related to concerned with any establishment / firm or any other person, who have filled in the tender for aforesaid work".

"I/We do hereby further undertake that, we have offered the best prices for the subject supply work as per present market rates. **Further, we do hereby undertake and commit that we do not offered / supplied the subject product / similar product / systems or sub systems in the past one year in the Maharashtra State for quantity variation upto -50% or +10% at a price lower than that offered in the present bid to any other outside agencies including Govt. / Semi Govt. agencies within B.M.C. also.** Further, we have filled in the accompanying tender with full knowledge of the above liabilities and therefore we will not raise any objection or dispute in any manner relating to any action including forfeiture of deposit and blacklisting for giving any information which is found to be incorrect and against the instruction and direction given in this behalf in this tender.

I/We further agree and undertake that in the event, it is revealed subsequently after the allotment of work / contract to me/us, that any information given by me/us in this tender is false or incorrect, I/We shall compensate the Brihanmumbai Municipal Corporation for any such losses or inconvenience caused to the Corporation, in any

manner and will not raise any claim for such compensation on any ground whatsoever. I/We agree and undertake that I/We shall not claim in such case any amount, by way of damages or compensation for cancellation of the contract given to me/us or any work assigned to me/us or is withdrawn by the Corporation."

However, in case of price difference, if it is a result differential tax structure, different Dollor values of Rupee, considering this aspect, before invoking the penalty, blacklisting etc., I/We will be given a reasonable opportunity being heard by representing our case as to why such price variation / differential has arisen.

In case, if the explanation submitted by me/us is unsatisfactory then action as stated above including forfeiture of Deposit & blacklisting may be taken against me/us.

TENDERER'S FULL SIGNATURE

WITH FULL NAME & RUBBER STAMP

**(Note:** This affidavit should be given on Rs. 200/- stamp paper duly notarized by Notary with red seal and registration Number.)

**PROFORMA-VIII**  
**Structure and Organisation**

1. The bidder is \_\_\_\_\_
  - a) an individual
  - b) a proprietary firm
  - c) a firm in partnership
  - d) a limited Company or Corporation
  - e) a group of firms/joint venture  
(if yes, give complete information in respect of each partner)
2. Attach the organization chart showing the structure of the organization, including the names of the directors and position of officers \_\_\_\_\_
3. Number of years of experience:
  - a) As a Prime Contractor  
(Contractor shouldering major responsibility)
    - i) in own country \_\_\_\_\_
    - ii) in other countries (specify country) \_\_\_\_\_
4. Name and address of any associates the bidder has in India (in case the bidder happens to be from foreign country) who are knowledgeable in the procedures of customs, immigration, taxes and other information necessary to do the work \_\_\_\_\_
5. For how many years has your organization been in Business of Installation & maintenance of road traffic Signal system work? \_\_\_\_\_
6. Were you ever required to suspend construction for a period of more than six months continuously after you started? If so, give the name of the project and give reasons therefor \_\_\_\_\_
7. Have you ever left the work awarded to you incomplete? \_\_\_\_\_  
(If so, give name of project and reasons for not completing work)

Sign & Seal of the Bidder/Tenderer

**PROFORMA-IX**

**Litigation History**

Name of bidder or partner of a joint venture
--

bidders, including each of the partners of a joint venture, shall provide information on any history of litigation or arbitration resulting from contracts executed in the last seven years or currently under execution. A separate sheet should be used for each partner of a joint venture.

Year	Award FOR or AGAINST bidder	Name of client, cause of litigation and matter in dispute	Disputed amount (Current Value- Rs. equivalent)

Sign & Seal of the Bidder/Tenderer

## PROFORMA - X

### Declaration from the Bidder for supply of supply of Truck mounted Aerial/Boom Lift Crane

I/We M/s ..... *[insert: name & address of Bidder]*  
agree that I/We have owned /hired the Truck mounted Aerial/Boom Lift crane Vehicle  
as mentioned in Bid Document for the work of **"Maintenance of ANPR cameras  
with associated accessories of Speed Violation Detection System in  
Brihanmumbai for the period of two years (01.09.2023 to 31.08.2025)"**. I/We  
assured that the Truck mounted Aerial/Boom Lift crane will be made available  
throughout the maintenance contract as and when required or as instructed by the  
Engineer. I/We assure that best services of Truck mounted Aerial/Boom Lift crane will  
be provided till end of the Contract.

Name & Signature of Bidder

## **BANKERS GUARANTEE IN LIEU OF CONTRACT**

### **DEPOSIT/PERFORMANCE**

THIS INDENTURE made this \_\_\_\_\_ day of \_\_\_\_\_ BETWEEN

THE \_\_\_\_\_ BANK incorporated under the English/Indian Companies Acts and carrying on business in Mumbai (hereinafter referred to as 'the bank' which expression shall be deemed to include its successors and assigns) of the first part \_\_\_\_\_

\_\_\_\_\_ inhabitants carrying on business at \_\_\_\_\_ in Mumbai under the style and name of Messer's \_\_\_\_\_ (hereinafter referred to as 'the contractor') of the second part Shri. \_\_\_\_\_

THE MUNICIPAL COMMISSIONER FOR BRIHANMUMBAI (hereinafter referred to as 'the commissioner' which expression shall be deemed, also to include his successor or successors for the time being in the said office of Municipal Commissioner) of the third part and THE BRIHANMUMBAI MUNICIPAL CORPORATION (hereinafter referred to as 'the Corporation') of the fourth part WHEREAS the contractor have submitted to the Commissioner tender for the execution of the work of " \_\_\_\_\_ and the

terms of such tender /contract require that the contractor shall deposit with the Commissioner as/contract deposit/ earnest money and /or the security a sum of Rs. \_\_\_\_\_ (Rupees \_\_\_\_\_) AND WHEREAS if and when any such tender is accepted by the Commissioner, the contract to be entered into in furtherance thereof by the contractor will provide that such deposit shall remain with and be appropriated by the Commissioner towards the Security deposit to be taken under the contract and be redeemable by the contractor, if they shall duly and faithfully carry out the terms and provisions of such contract and shall duly satisfy all claims properly chargeable against them there under AND WHEREAS the contractor re constituents of the Bank and in order to facilitate the keeping of the accounts of the contractor, the Bank with the consent and concurrence of the contractor has requested the Commissioner to accept the undertaking of the Bank hereinafter contained, in place of the contractors depositing with the Commissioner the said sum as earnest money and /or security as aforesaid AND WHEREAS accordingly the Commissioner has agreed to accept such undertaking NOW THIS AGREEMENT WITNESSES that in consideration of the premises, the Bank at the request of the contractor (hereby testified) UNDERTAKES WITH the commissioner to pay to the commissioner upon demand in writing, whenever required by him, from time to time, so to do, a sum not exceeding \_\_\_\_\_ in the whole Rs. \_\_\_\_\_ (Rupees \_\_\_\_\_) under the terms of the said tender and /or the contract. The B.G. Is valid upto \_\_\_\_\_ "Notwithstanding anything what has been stated above, our liability under the above guarantee is restricted to Rs. \_\_\_\_\_ only and guarantee shall remain in force upto \_\_\_\_\_ unless the demand or claim under this guarantee is made on us in writing on or before

\_\_\_\_\_all your right under the above guarantee shall be forfeited and we shall be released from all liabilities under the guarantee thereafter”

IN WITNESS WHEREOF

WITNESS(1) \_\_\_\_\_

Name and \_\_\_\_\_

address \_\_\_\_\_

WITNESS(2)\_\_\_\_\_

Name and \_\_\_\_\_ the duly constituted Attorney Manager

address \_\_\_\_\_

the Bank and the said Messer’s \_\_\_\_\_

\_\_\_\_\_ (Name of the Bank)

WITNESS(1)\_\_\_\_\_

Name and \_\_\_\_\_

address\_\_\_\_\_

WITNESS(2)\_\_\_\_\_

Name and \_\_\_\_\_

For Messer’s\_\_\_\_\_

address \_\_\_\_\_

have here into set their respective hands the day and year first above written.

# **SECTION 15**

**List of the Location**

### **List of the Location of Speed Violation Detection System**

<b>Sr. No.</b>	<b>List of Location</b>	<b>No. of Lane</b>
1	N S Road near Marine line Gymkhana	6
2	Vakola at Western Express Highway	8
3	Kanjur Gaon at Eastern Express Highway	6
4	Worli Bandra Sea Link near Toll Plaza	6
5	Worli Bandra Sea Link towards South	4
6	Worli Bandra Sea Link towards North	4
7	Bhakti Park on Eastern Freeway	6
8	Panjarpole on Eastern Freeway	4
9	Sewree on Eastern Freeway	4
10	Cotton Green on Eastern Freeway	4
11	GMLR location 1	6
12	GMLR location 2	6

It may be noted that ANPR cameras with associated accessories at sr. no. 11 & 12 being installed at GMLR flyover location 1 & 2 which will be handed over for maintenance after the completion of Defect Liability period.