

बृहन्मुंबई महानगरपालिका

परिपत्रक

प्र.ले./वित्त/प्रकल्प/शहर/१७ दिनांक: ०६.०९.२०१७

विषय: जीएसटी अंमलबजावणीनंतर महानगरपालिकेतील कंत्राटांत होणा-या बदलाबाबत.

- संदर्भ: १) शासन परिपत्रक क्र.जीएसटी-१०१७/प्र.क्र.८१/कराधान-१ दिनांक १९, ऑगस्ट, २०१७.
२) परिपत्रक क्र. प्र.ले./वित्त/प्रकल्प/शहर/१६ दिनांक: ३१.०८.२०१७
३) परिपत्रक क्र. प्र.ले./वित्त/प्रकल्प/शहर/८ दिनांक: १४.०७.२०१७

दिनांक १ जुलै, २०१७ पासून वस्तु व सेवा कर अंमलात आला असून त्या अनुषंगाने महाराष्ट्र शासनाच्या वित्त विभागाने उपरोक्त संदर्भ क्र. १ च्या परिपत्रकान्वये मार्गदर्शक सूचना प्रसूत केल्या आहेत. सदर सूचनांच्या अंमलबजावणीसाठी महापालिकेने संदर्भ क्र. २ अन्वये परिपत्रक जारी केले आहे. सदर शासन परिपत्रकातील मार्गदर्शक सूचनांची महापालिकेत अंमलबजावणी करण्याच्या दृष्टीने खालील प्रमाणे अतिरिक्त निदेश देण्यात येत आहेत.

१) शासन परिपत्रकातील बाब क्र. १:- दिनांक २२ ऑगस्ट, २०१७ नंतर काढण्यात येणारी कंत्राटे:

यापुढे मागविण्यात येणाऱ्या, प्रत्येक दरपत्रिका/अतारांकित निविदा/ई-निविदांमध्ये वस्तु व सेवाकराच्या बोजाचा विचार करूनच निविदाकारांनी दरपत्रिका/अतारांकित निविदा/ई-निविदांचे दर सादर करण्यासाठी उपरोक्त संदर्भित क्र. ३ परिपत्रकामध्ये दिलेल्या अटीचा, त्याचप्रमाणे खालील अटीचाही समावेश करावा.

“Chapter XXI-Miscellaneous, section 171(1) of GST Act, 2017 governs the ‘Anti Profiteering Measure’ (APM).

As per the provision of this section, ‘Any reduction in rate of tax on any supply of goods or services or the benefit of input tax credit shall be passed on to the recipient by way of commensurate reduction in prices’

Accordingly, the contractor should pass on the complete benefit accruing to him on account of reduced tax rate or additional input tax credit, to MCGM.

Further, all the provisions of GST Act will be applicable to the tender.”

२) ज्या दरपत्रिका/अतारांकित निविदा/ई-निविदा २२ ऑगस्ट, २०१७ पूर्वी मागविलेल्या आहेत व ज्यांचा लिफाफा अ उघडण्यात आलेला नसून त्यांच्या नियत दिनांकास अजूनही अवधी शिल्लक आहे, अशा दरपत्रिका/अतारांकित निविदा/ई-निविदांच्या बाबतीत, सक्षम प्राधिकार्याच्या मान्यतेने, शुद्धीपत्रकाद्वारे (Corrigendum), वरिल बाब क्रमांक १ मध्ये दिलेल्या अटीचा समावेश करावा व त्यासाठी आवश्यक असल्यास नियत दिनांक वाढविण्यात (Extend) यावी.

३) अतितात्काळ कामे:

शासन परिपत्रकाप्रमाणे, अतितात्काळ स्वरूपाच्या कामाबाबतच्या निविदांची प्रक्रिया पूर्ण करण्यात येऊन त्यांचे कार्यारंभ आदेश देण्यात यावेत. मात्र सदर निविदा स्विकृत करताना जीएसटी अंतर्गत येणाऱ्या कराचा बोजा लक्षात घेऊन कंत्राटदाराशी वाटाघाटी करून दर कमी करण्याचा प्रयत्न करण्यात यावा. तथापि, त्याआधी अशी कामे अतितात्काळ असल्याबाबतच्या समर्थनिय सविस्तर कारणासह प्रस्ताव सादर करून संबंधित अतिरिक्त आयुक्त यांची प्रशासकिय मान्यता घेणे आवश्यक आहे.

सर्व खातेप्रमुख/सहा.आयुक्त/वैद्यकिय अधिष्ठाता यांनी त्यांच्या अखत्यारीतील सर्व अधिकारी/कर्मचारी यांना उपरोक्त सूचनांची काटेकोरपणे अंमलबजावणी करण्याचे आदेश द्यावेत.

(स.क.आव्हाड)

प्रमुख लेखापाल (पा.पु.म.नि.)

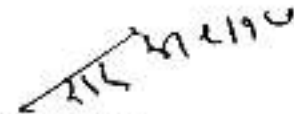
(राम धस)

उप आयुक्त (म.ख.खा.)

(प्रदिप पडवळ)

प्रमुख लेखापाल (वित्त) प्र.

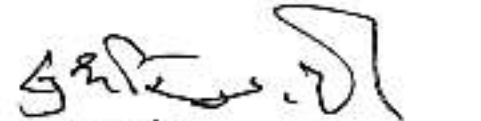
(सुधीर नाईक)

उप आयुक्त (सा.प्र.)

(डॉ. संजय मुखर्जी)
अतिरिक्त आयुक्त (प्रकल्प)

MUNICIPAL CORPORATION OF GREATER MUMBAI

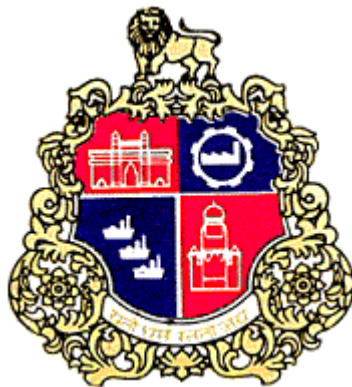

GUIDELINES FOR TRENCHING ACTIVITY- 2015



No: AMC/ES/7725/II Dated 18.12.2014

Policy guidelines for granting trench excavation permissions to underground service provider Utility agencies and Municipal agencies & the reinstatement of trenches

FOREWORD

The last comprehensive policy on trenching was issued in 2007 in form of booklet. Thereafter several circulars came to be issued on account of changing circumstances and shift in policies. New methods of trenchless technology like horizontal directional drilling (HDD) have been introduced in MCGM recently and the same are being encouraged to minimize open cut excavation. Micro Trenching method, which is less invasive in nature too is relatively new technology which has been introduced in MCGM. The trenching methods are evolving as the time is advancing.

RMMS too has been introduced in MCGM with a view to create database of all the roads consisting the features like road width, length, surface etc, extent of deterioration etc which will help identifying need for repairs of road. For the implementation of RMMS, road engineers have been appointed in wards. These Road Engineers have been entrusted with the trench work. The Road Engineers; most of them who are freshers or are with relatively less experience in field, who need to be provided with handy guidelines. The previous guidelines being scattered in various circulars hence may create confusion in minds of some

Considering all these factors and aspects, a need has emerged to issue fresh comprehensive guidelines on trenching. With this view in perspective, these fresh guidelines are being issued.

In these guidelines, the procedure to be adopted by the Road Engineers while processing applications of Utility Agencies have been explained in minute details. More importantly, the trench width for improvement has been reduced from 2.4M to 2.0M. Flat rates to be adopted for arriving at Reinstatement charges have been worked out afresh.

New chapters on HDD and Micro Trenching have been introduced. Principles for laying underground services by using HDD method and Micro Trenching method have been fixed.

I present these guidelines with pleasure and with hope that all the Road Engineers, Utility agencies will find it useful as all about trenching has been included in these guidelines.

All the permissions that will come to be issued henceforth will be subject to these policy guidelines. The Road Engineers as well as the Utility Agencies shall take note of it. These guidelines will come in to effect from 01.02.2015.

Sd- 18.12.2014
S V R Srinivas (IAS)
Addl Municipal Commissioner (ES)

No: AMC/ES/7725/II Dated 18.12.2014

Policy Guidelines for Granting of Permission to Utility and Municipal Agencies for Excavation and Reinstatement thereafter

Part A-General

1. This circular supersedes all the previous circulars with regards to granting of permission for excavation for laying underground utilities, recovery of reinstatement charges & security deposit from utility agencies, reinstatement of trenches, refund of the deposits etc.

No modifications have been suggested in the following existing annexures in the previous trenching policy issued u/no MGC/F/1835 of 17.11.2007. Annexure-2 i.e. Joint inspection report, annexure-11 i.e. Details of barricades, display boards, annexure-12 i.e. daily progress report of utility agency, annexure-13 i.e. daily progress report of reinstatement contractor, annexure-15 i.e. reconciliatory statement, annexure-16 i.e. reconciliation letter to utility agency, annexure-17 i.e. forms of registers.

With a view to instill a sense in all so that the newly improved public streets are not dug up for planned works of utility agencies in disorderly, disorganized & indiscrete manner; the multiplying factors for arriving at the reinstatement charges along roads under defect liability period have been enhanced as given under the Annexure-A. However, it shall be endeavored that no permissions are issued in first year of defect liability period for trenches proposed by the utility agency for planned work

Penalties for various lapses applicable to the utility agency and the reinstatement contractor have been enhanced and have been annexed as Annexure-B to these guidelines. Schedule of flat rates and details mentioning the multiplying factors to be used for arriving at reinstatement charges depending upon defect liability period of the roads have been added as Annexure-A. Cross sections of reinstatement to be made; in footpath as well as in asphalt and sample estimates for reinstatement of trench in footpath as also in asphalt carriageway have been annexed as various annexures.

2. This circular is applicable to all the utilities including all agencies of M.C.G.M. which will be excavating road surfaces for laying services.

3. The practice of submission of application for permit, issuing demand note and permit; issuing work order to reinstatement contractor shall be continued as per existing practice which is in consonance with previous trenching policy issued u/no MGC/F/1835 of 17.11.2007. No changes have been proposed in the said process or the existing formats for the same.

On the printed application form; it shall be mentioned that the application being made by the applicant for permit to excavate trench is subject to terms and conditions contained in this circular being issued u/no..... Also; while issuing the permit it shall be clearly mentioned in the permit that the permit has been issued to subject to terms and conditions contained in this circular being issued u/no

AE (Maint) of ward and ward Road Engineers (as defined in the Road maintenance circular issued u/no AMC/ES/5461/II dated 05.04.2014) shall process the application of the utility agency. Obtain NOCs of Roads department wherever necessary and issue demand notes.

After receipt of payment towards reinstatement charges, permit shall be issued; mentioning therein clearly the date of starting and completion of trenching. All these activities shall be processed through SAP as is the prevailing practice. No changes have been proposed in the current proforma of application form to be filled in by the utility agency, demand note, permit & the work order to be issued to ward trenches contractor.

4. Regarding Obtaining NOCs of Road Department:

For flexible roads under defect liability period of Road Department, for trenches to be taken in flexible side strips of CC roads which are under defect liability period and for the project roads included in ongoing contracts of Road Department; NOC from office of concerned Deputy Chief Engineer (Roads) shall be obtained. Astdt Engineer concerned from respective Divisional office of Road department shall issue the NOCs in the above mentioned cases after obtaining approval of Executive Engineer concerned.

For trenches proposed in CC carriageway of a road i.e. trench to be taken by breaking the pavement quality concrete of the road; whether the said CC road being within the defect liability period of road department or not as also for the micro-trenches along all the roads; whether the road being under defect liability period of Road department or not; NOC in all such cases; whether for internal agency or for external agency; shall be obtained by AC of respective ward from concerned Deputy

Chief Engineer (Roads); who in turn will issue such NOC after obtaining approval of Chief Engineer Roads.

The NOC from Road Department shall indicate nature of surface of road e.g. mastic/bitumen/paver blocks/PQC grade concrete etc. It shall mention thickness of paver blocks if trench is proposed in paver blocks, current year of defect liability period and total defect liability period of the said road where trench is proposed so as to make it convenient to the ward RE to arrive at RI charges by using appropriate multiplying factor and the flat rate.

Except for above, in all other cases NOC of road department is not necessary for processing trench applications; hence all applications shall be processed at ward level.

5. Reinstatement of trenches:

Along the roads; which are under Defect Liability Period of Roads Department and where such condition to this effect exists in the road contract that reinstatement of the trenches permitted along roads improved under the contract shall be carried out by the respective Roads department contractor as per rates of prevailing Fair Market Schedule/USOR; at the percentage quoted on original contract; as defined more specifically in the terms & conditions of the said contract; then in such cases reinstatement of the trenches taken along roads improved under such contracts shall be carried out by the respective Road Department contractor in the manner as specified in respective contract.

In case of those old contracts still under defect liability period of Roads Department; where it is included in contract document that reinstatement of trenches taken along roads improved under the said contracts is to be carried out by the respective Road Department contractor; which contracts; however were latter brought under the ambit of circular issued u/n Ch E/12567/Rds & Tr dated 17.01.2009; in so far as reinstatement of trenches was concerned, it is clarified that in such cases; reinstatement of the trenches taken along roads improved under such contracts shall be carried out by the respective Road Department contractor at prevailing rates of Fair Market Schedule/USOR; at the percentage quoted on original contract.

The reinstatement work order will be issued by the AE (Maint) of ward and the reinstatement of trench will be carried out under supervision of ward RE. The payment of the work carried out will be made to the Road department contractor by AE (Maint) of ward as per the terms and conditions of the respective Road department contract. Defect liability period of such reinstated trenches will be three years or remaining defect

liability period of the road contract whichever is later. Divisional Deputy Chief Engineers (Roads) shall forward to the respective ward office details of all the ongoing project road contracts in jurisdiction of said ward along with list of roads proposed to be improved under the said contract along with phase wise program of improvement of the roads; And; details of contracts under defect liability period of road department along with all the relevant details such as copy of work order of the contract, actual date of completion of contract, total defect liability period of contract and one copy of the contract document highlighting the conditions relevant to reinstatement of trenches.

In case of ongoing project road; while granting permission to utility agency for excavation; AE (Maint) of ward shall put condition in the permit that the excavation for trench shall be taken in coordination and consultation with concerned Deputy Chief Engineer (Roads) as reinstatement of such trenches taken along ongoing project roads will be carried out while taking up improvement of the said road by the Road Department contractor. It shall be so arranged that the excavation of trench by Utility agency is taken simultaneously with road excavation for improvement work so that trenches do not remain unattended for long period and reinstatement of trench can be carried out in comprehensive manner along with road improvement work guaranteeing superior work quality.

Road department while taking up new roads for improvement shall obtain remarks from all utility agencies, external as well as internal and shall incorporate the planned works of internal agencies in its tenders considering integrated project approach so as to avoid digging by internal agencies for planned works during Defect Liability Period of the road.

External agencies shall be informed well in advance by concerned Deputy Chief Engineers (Roads) about improvement of roads through upcoming tenders along with the list of roads proposed for improvement. External agencies shall be informed that they shall carry out laying of utilities for planned nature of works, shifting/realigning of existing service lines before commencement of road improvement work. It shall be stressed that no permission will be granted for planned nature of works during Defect Liability Period of the work. The utility agencies too proactively shall obtain list of roads proposed for improvement from divisional roads offices by coordinating with concerned Astd Engineers and further shall carry out the planned jobs, shifting/realigning of existing service lines along such roads before commencement of road improvement work or during execution of road improvement work, whichever is suitable in the opinion of the Deputy Chief Engineers of Road department. External utilities shall note

that no permissions will be granted to excavate along roads which are under defect liability of roads department for carrying out planned jobs.

If in case any external utility agency comes up with a proposal to take excavation for laying utility services along a road under defect liability period of roads department citing expedient circumstances then in such cases; the RI charges arrived at by multiplying the flat rates by telescopic multiplying factors as mentioned at Annexure-A; depending upon year of defect liability period of the road under reference shall be recovered from the concerned agency.

It will be mandatory on part of the external utility agencies to submit their ward wise annual plan for executing planned works over following fair season to respective ACs of wards in whose jurisdiction the works fall and as well as to concerned Deputy Chief Engineer (Roads) and to the Chief Engineer (Roads & Traffic) by 30th June every year. The external agencies shall prepare their annual utility laying plans meticulously; with forethought & foresight; as no alterations will be permitted in the annual plan in later stages under any circumstance. This exercise has been adopted out of necessity as unplanned excavation for trenching activities is leading to a complete disorder and disorganized excavations in haphazard manner along roads by multiple agencies. The annual excavation plans received from various agencies shall be uploaded on MCGM portal by respective Astt Commissioners. AE (Maint) and concerned Road Engineers of wards shall scrutinize the annual excavation plans submitted by the Utility Agencies and process those in such a manner that excavations are allowed to the agencies right from 01 October of every year in an organized manner so that minimum disruption is caused to traffic and multiple utility agencies can lay their services in the same trench.

If work of laying of utilities is proposed by Municipal agencies like Sewerage Project, SWD, Hydraulic Engineer etc., provision for reinstatement of proposed trenches shall be made in their tenders. Minimum Defect Liability Period of reinstated stretches shall be kept as three years. Departments other than Road department shall not carry out reinstatement of trenches along CC roads in PQC; it being a specialized job.

In all other cases, reinstatement of trenches shall be carried out by the Ward Trenches contractor, who will be appointed from time to time by Deputy Chief Engineer (Roads) Planning. The reinstatement carried out by ward trenches contractor shall be either in asphalt or paver blocks according to the nature of existing surface. The defect liability of trenches reinstated by ward trenches contractors will be two years from date of completion of reinstatement of individual trench.

5. For effective implementation of this circular, there shall be proper coordination between the Ward RE, Engineer from Utility/Municipal agency and reinstatement contractor (Ward trenches contractor or Municipal agency contractor) & Engineers from Road department if the road in question is ongoing project road.

6. **Reinstatement Charges:**

Flat rates applicable for arriving at reinstatement charges for various road surface based on prevailing Unified Schedule of Rates as well as charges for using existing duct will be as per Annexure-A. These rates have been worked out considering the width of trench as 0.9M, average depth of 0.9M and 0.55M width of affected area of road on each side; i.e. the total width of road to be improved will be 2.0M as against 2.4M as per previous practice. Along with reinstatement charges; 50% additional amount shall be obtained from the utility agency as security deposit which can be utilized to recover penalties for various lapses, additional reinstatement charges in case the utility agency exceeds the excavation than length allowed in permit etc. Such deposit which has to be deposited with MCGM with each and every permit can be waived; if the utility agency deposits certain fixed amount of standing security deposit with MCGM for the purpose stated hereinabove. The Astt Commissioner of respective ward shall decide the amount of such standing security deposit which in his opinion will be sufficient to meet the recoveries from the utility agency. If the utility agency deposits such standing security deposit with the respective ward then no separate security deposit shall be insisted along with demand note

With innovations in compactor manufacturing technology, Vibratory tandem compactors with lesser wheel width yet with superior compacting attributes are available. This has afforded us an opportunity to reduce the width of trench for reinstatement from 2.4M to 2.0M. Vibratory compactors having specifications similar to Caterpillar CD54B solid drum compactor shall be deployed on site.

The ward RE and the trench reinstatement contractor; for achieving effective compaction; shall ensure that the width of wheels of road roller to be used on site for reinstatement purpose is less than the trench width i.e. 2.0M as well as it shall be ensured that the roller exerts minimum 10T pressure during rolling.

In case of project roads which involve widening of roads; it is necessary to shift utilities/lay new cables to the edges of the widened road; so as to avoid excavations in central of carriageway in future. In such cases the laying new utility services/realigning/shifting of existing services is desirable when project roads are

under construction. In such cases; the reinstatement cost should be recovered based on the actual cost of granular filling in the trench, removal of surplus earth, GSB course and Base course, along with supervision charges, other budgetary overheads + Service Taxes as may be applicable.

If at any given time it is noticed that a trench has been taken by any utility agency to lay its services without obtaining valid excavation permit from ward, then in such cases, apart from the regular reinstatement charges, twice the amount of applicable reinstatement charges will be recovered as penalty. If such total amount i.e. reinstatement charges plus penalty amount is not deposited with respective ward of MCGM within seven days of demand, then such agency will be black listed across MCGM and no new permits will be issued to it till the said amount is deposited

6 A. Access charges (Right of way charges):

In addition to the regular RI charges; access charges for right of way will be recovered by MCGM from all utilities which lay underground services below MCGM roads. Presently these charges will be recovered at the rate of Rs100/- Per Meter length of the cables/conduits/ducts Per Year. The Access charges will be enhanced as and when it is felt expedient to MCGM. On demand from MCGM or rather proactively; the access charges shall be deposited year by year by the Utility agencies. The access charges will be applicable to all types of trenching works i.e. open cut trenching, HDD & Micro trenching. Applicable access charges in individual case shall be informed to the applicant utility agency through demand note along with the reinstatement charges.

7. Concerned RE of ward will be in charge of all the trenching activities in his RMMS cluster. He shall process the trench applications received in ward, obtain timely sanctions, issue demand notes & permits and monitor the trenching activity and reinstatement of the trenches. The RE will be solely responsible for proper and quality work of reinstatement of the trenches. There shall be constant and close supervision by the concerned ward RE right from commencement of trenching up to effective completion of reinstatement of trenches. In case of ongoing project roads of Road Department; the ward RE shall act as coordinator between the utility agency and concerned AE (Roads) from Road department to see that the reinstatement of trenches taken along such roads is carried out by Central agency. In such cases however, responsibility of getting quality work done will be of the Central Agency.

Immediate supervision over the ward RE for ensuring quality of the reinstatement of trenches shall be of AE (Maint) of ward. Ward EE shall take surprise rounds along randomly selected sites to observe the trenches work.

8. The defect liability period of two years for the ward trenches contract will not be applicable to contract as a whole. The defect liability period will be reckoned independently for each trench. The defect liability period of a reinstated individual trench will commence from date of completion of the trench as recorded in the Trench Tracking System. The defect liability period for the trenches will be two years flat from completion date of reinstatement.

9. No PQC work shall be carried out through Trenches contractor. This condition shall be incorporated in tender by Deputy Chief Engineer (Roads) Planning

10. In case the trench gets damaged/settled due to improper workmanship and/or defective material; the ward trenches contractor shall redo it at his risk and cost as directed by the engineer to his satisfaction.

11. On account of various lapses by the Utility agency as well as the Trench Reinstatement Contractor penalties shall be recovered as per Annexure **B**.

12. The Engineer of trenching contractor shall submit daily progress report in the prescribed format enclosed with this booklet.

13. For expeditious completion of work, while the Vigilance Department may inspect the site and point out defect immediately, however they shall not instruct stoppage of the work.

14. The Head Clerk (Expenditure) of the Ward shall maintain proper register in the format in prescribed format enclosed with this booklet.

Part B – Laying/replacing of services

Permission for laying/augmentation of the utility conduits/cables shall be granted during the fair season from 1st October till 15th April. For trench exclusively on footpaths, the permission shall be granted up to 30th April.

The utility agency proposing to undertake the trench shall make an application in the prescribed format. On receipt of application, ward RE along with the representative Engineer from Utility and Engineer of Trenches Contractor shall visit the site jointly and verify the details given in application, if any discrepancy is observed between information furnished by Utility Agency in application & related details on site; then necessary changes shall be made in the application form & such changes shall be

authenticated by the Utility agency engineer, Ward RE. The application shall be accompanied by to the scale drawing of the proposed trench

1. Trenches for laying pipelines or cables shall be allowed as close as possible to the edge of carriageway; without damaging the water entrances.

2. For preparing Demand Note, for recovery of reinstatement charges from utility agency, for preparation of estimate for actual reinstatement, length of trench irrespective of whether it is on footpath /passages, carriageway, shall be taken from the nearest property entrances/road junction from the starting and ending point of the trench. However, if property entrance/road junction is at a distance more than 25 Meter from start/ end point of the trench, then length shall be taken as actual trench length plus 25 Meter on the both end of the trench.

3. If the excavation is proposed along slum passages; irrespective of whatever may be original surface finish, the flat rate with 80MM thick CC paver block surface shall be considered for preparing Demand Note & estimate for reinstatement work. Reinstatement too shall be done with the paver blocks.

4. If excavation is proposed along footpath, then invariably the flat rate for 60MM thick lacquer finish paver blocks shall be considered for preparing Demand Note, estimate and reinstatement. However, if the existing finish of footpath is in superior quality of paver blocks surface than 60MM thick lacquer finish blocks then in such cases such superior paver blocks surface shall be considered for preparing Demand Note, estimate and reinstatement.

5. If excavation is proposed on the carriage way, the flat rate of original surface finish shall be considered for preparing Demand Note, estimate and reinstatement.

6. For the purpose of recovery of reinstatement charges, the Demand Note shall be prepared with the flat rate considering telescopic charges (Multiplying factors) as per **Annexure-A** in accordance with Defect Liability Period of concerned road/footpath.

7. For the purpose of preparing an estimate for reinstatement of trenches through the Ward trench contractor, items and their rates shall be as per the BOQ of the contract awarded. Sample estimate for reinstatement of trench considering 2 M footpath and trench of 10M length, 0.90 M width and 0.785 M depth is at **Annexure-E**; Sample estimate for reinstatement of trenches considering 2.0M wide carriageway and trench of 10 length, 0.90 M width and 0.915 M depth is at **Annexure-F**.

8. Wherever required raising of kerb stone shall be considered while preparing the estimate. While preparing the estimate, at least **10%** of length of the trench shall be

considered for replacement of kerb stone and at least **10%** of laterals shall be considered for replacement.

9. During reinstatement of trenches; the backfilling of trench shall be done by ward trench contractor/concerned department with graded granular material. Number of layers of graded granular material however shall be restricted to five layers of maximum depth 150MM.

10. If multiple utilities are laying conduits/cables in one single trench; then in such cases; the RI charges shall not be divided among all the trench sharing utilities. Individual RI charges shall be worked out separately for all the utility agencies independently depending upon the length of trench proposed by the respective utility agency. Such RI charges shall be informed to all involved utility agencies individually and shall be recovered from all the agencies. Unless all the utilities involved pay the RI charges, trench opening permit shall not be issued.

11. For the purpose of recovery of penalties and other violations as well as to recover RI charges for reinstatement of faults; the utility agencies which are in frequent need of trenches, shall pay a standing deposit of appropriate amount to MCGM. The appropriate amount may be calculated by the Astd Commissioner of the respective Ward considering the probable recoveries to be made for penalties and other violations of the guidelines.

12. Time period for completion of work shall be proportionate to the length of trench and it shall be calculated as **three** days for trench of 100 Meter.

13. On preparing the demand note along with inspection report, estimate prepared shall be put up before appropriate authority for the sanction to grant permission for excavation.

14. Permission for taking excavation of trench up to 1000M shall be considered by the concerned Astd Commissioner. For trench length more than 1000 Meter; approval of the zonal D.M.C. shall be obtained.

15. Similarly if permission is to be granted with time period more than fifteen days, sanction of Zonal DMC shall be obtained.

16. Considering the time required for obtaining various sanctions, sufficient time of at least one week may be considered between submission of proposal and sanction.

17. In case excavation is proposed to be taken across carriageway, condition of laying the pipeline/cable through duct and laying of additional 2 ducts of 300 mm dia N.P. Class II pipes or equivalent with encasing in M15 (1:2:4) concrete by utility agency shall be incorporated in the permit.

18. Erection of boxes, pedestals, etc. above the ground; erection of manhole, handouts, etc. below the ground can be considered with specific prior sanction of zonal D.M.C.
19. Flat seven days' time will be allowed to complete the reinstatement of trench up to 500M length. For per additional length of 200M trench reinstatement or fraction thereof, additional two days of time period will be allowed.
20. In view of ensuring completion of trench within prescribed time limit utility agency shall mobilize all the resources well in advance before undertaking the excavation including obtaining permission from traffic police.
21. On receipt of permission, utility agency shall immediately start the excavation and under no circumstances deviation from the permitted start and end point will be allowed. Similarly, length and width of trench shall not be increased under any circumstances. Before starting the excavation, area shall be barricaded as stipulated in prescribed format enclosed with this booklet. Reflector signs shall be provided on the barricade all along the trench as per prescribed format enclosed with this booklet and lighting arrangement shall be made during night time to caution road users.
22. Utility agency shall display notices/convenience boards at the start and end of trench. If the trench is more than 100 Meter, boards shall be displayed in between and at junctions. Boards must display information such as (a) Copy of permit (b) name of Site Engineer (c) Contact No. (Mobile) (d) Boards with **"Inconvenience caused is regretted"** written in bold letters
23. Water entrances and chambers having opening shall be properly covered to avoid entry of excavated earth in it. After completion of work; the water entrances shall be uncovered and cleaned by the utility agency.
24. While carrying out excavation, it shall be seen that surface tiles/paver blocks, etc. are removed carefully and stacked properly.
25. Utility Site in-charge shall submit a daily report to M.C.G.M. Engineer in prescribed format enclosed with this booklet.
26. At the appropriate locations, steel plate shall be provided at the trench for crossing of vehicular and pedestrian traffic.
27. If trench is more than 100 Meter in length, the utility shall undertake 100 Meter trench at a time, lay the pipeline/cable and clear the site for reinstatement and movement of traffic and only then further excavation shall be undertaken. However, in case of laying of power cable of length in which case unless complete length is excavated the cable cannot be laid, under the circumstances, 250M trench at a stretch

may be allowed. If more length than 250M in one stretch is required then in such case, the zonal DMC may consider the case on merits.

28. All the excavated earth shall be placed in bags/containers and shall be transported within 24 hours to the sites owned by the respective agencies. Depending upon availability of the Municipal dumping grounds; MCGM may or may not allow removal of surplus earth to its dumping grounds.

29. On completion of reinstatement, reconciliation statement by adding the amount of penalties for various lapses as per Annexure-B shall be prepared in prescribed format enclosed with this booklet and be sent to Accounts Officer either for refund of remaining deposit or recovery of charges as the case may be.

30. In case the utility agency defers the excavation after issue of permit then the work order issued to the Ward Trenches Contractor shall be cancelled. Copy should be sent to Account Officer for refund of charges recovered for particular trench from the utility. The intimation to this effect should also be sent to utility agency in prescribed format enclosed with this booklet.

31. In case the utility agency undertakes excavation of lesser length than length permitted as per excavation permit, then though the estimate for reinstatement is prepared according to length mentioned in permit, the reinstatement should be executed for actual trench length. Payment to ward trenches contractor should be made accordingly for the actual work done on site. Similarly the balance RI charges recovered from the utility for reinstatement shall be refunded immediately.

32. In case the utility agency excavates excess trench length than the length allowed in permit, the agency shall be penalized as per **Annexure-B**. In such case, though work order given to ward trenches contractor is for lesser length, the reinstatement shall be carried out under same work order for actual length of trench on site and the extra excess to this effect should be paid to the Ward Trenches Contractor with the sanction of Astt Commissioner. For extra trench work carried out by the utility, RI charges shall be recovered at 1.5 times of the actual RI charges applicable. Such excess charges, amount of penalty shall be recovered from the agency through its standing deposit or the security deposit paid by the agency along with RI charges. Such amounts shall be informed to the utility agency through reconciliatory statement in prescribed format enclosed herewith and shall be recovered forthwith.

33. On completion of reinstatement, bills of Ward Trenches Contractor shall be prepared by deduction of amount for various lapses made while carrying out reinstatement as mentioned in **Annexure-B**. Similarly, reconciliation statement shall be

prepared in prescribed format enclosed with this booklet and submitted to the Accounts Officer within **Fifteen days** from the date of completion of reinstatement work. The Accounts Officer, within the next **seven days** shall verify the reconciliation statement, make payment to the contractor and send file to the AE (Maint) within the next **two days**, AE (Maint) shall reply to utility for further necessary action as the case may be.

34. Wherever a new water or sewerage connection is required to be provided to the private party, such private party shall be treated as Utility under this circular and all the procedures laid down shall be followed.

While granting stand post water connection in slum area, being weaker section, reinstatement charges (as payable to reinstating agency including administrative charges) will be recovered from the connection holder. In such cases, reinstatement shall be carried out in existing road surface. For paver blocks in slum area, width of trench shall be considered as 1 m or actual width whichever is more.

35. In case utility agency fails to start the work by the date of completion mentioned in the permit and seeks revalidation of the permit; or the trench reinstatement contractor fails to start work on appointed date and seeks distant date; same may be considered by zonal DMC after reviewing facts of the case

In case utility agency/ward trench reinstatement contractor delays completion of their work then they shall be penalized as per Annexure-B. However, if it is found that the circumstances due to which their activities are delayed were beyond their control, under the circumstances the penalty may be waived off by the zonal D.M.C. considering facts of the case.

Part C- Fault repairs

1. As far as possible, all utility agencies including Municipal agencies shall seek prior permission before undertaking excavation for fault repair. In case of compelling circumstances, at least a written application seeking permit for fault repair shall be submitted to the concerned ward before taking up the excavation. If such emergency situation of repairs to faults of power cables/water supply lines etc. occurs beyond working hours then the application shall be submitted to the Disaster Control cell functioning round the clock in wards offices. It may so happen at times that fault on power cables has to be attended at odd hours on urgent basis to restore supply, then in such circumstances; at least an SMS shall be forwarded to concerned AE (Maint) of ward/RE and the respective Executive Engineer of the Roads Department. However, for attending faults where it is necessary to break CC road then aforesaid relaxations are

not applicable. In such cases, prior permit must be obtained; and till such time; alternate arrangement like laying well insulated cables along aerial routes may be adopted. This relaxation is for power cables and water supply lines. For faults on all other services, regular written application shall be made in respective ward.

2. It is often observed that even though alternate arrangement is established, the utility agencies undertake excavations under the guise of fault repair. This should be absolutely barred and penalized as per **Annexure-B**.

3. For the purpose of reinstatement of faults, sufficient amount of deposit shall be deposited by the utilities as decided by Astt Commissioner.

4. From the **16th April to 30th September**, for the fault repair, sanction of Zonal DMC shall be obtained as far as possible before undertaking excavation. For attending faults on LT Cables; up to 10M excavation, for faults on 11 KV cable; up to 15M and for faults on 22 KV cable up to 20M excavation shall be allowed. Utility shall start excavation, repair the fault, remove excavated earth, etc. within maximum of **48 hours**.

5. Excavations are undertaken by various Municipal agencies like Water works, Sewerage Operation, S.W.D for repairing SWD/sewer/water Pipe lines, etc., in such case also, all conditions laid down shall be followed.

6. Concerned Municipal agencies shall ensure that they deposit sufficient amounts well in advance with Accounts Officer of the Ward to facilitate the reinstatement of trenches.

7. The instructions mentioned in Part B Laying/replacing services shall also be followed for this part as well.

8. Reinstatement of trenches taken for fault repairs shall be done through Ward Trenches Contractor or through concerned agency of road Department if there is provision in the contract.

9. For effective reinstatement of excavation made for fault repair, concerned RE shall consolidate utility-wise all cases of excavations for trenches in his cluster taken for fault repairs in the preceding week and on **every Thursday**, he shall prepare utility wise estimates and issue the work order to Ward Trenches Contractor on the basis of estimate without waiting for booking of liability by the Accounts Officer. A copy of such work order shall be sent to Accounts Officer for booking the liability and debiting the amount from deposit received from the respective utility.

10. Reinstatement contractor shall carry out reinstatement during dry spell within **two days**. This process shall be followed every week.

11. For preparing an estimate, width of reinstatement on footpath/passages shall be same as that mentioned for laying of new services. Similarly surface finish shall be considered of 60MM thick lacquer finish paver blocks OR the existing surface finish; if it is superior to 60MM thick lacquer finish paver blocks. As regards length, it shall be additional 1 Meter on either side of the actual trench. If repair of fault is on carriageway, estimate shall be prepared for 2.0 Meter width with original surface finish. In no case, a trench taken for fault repair by the utility shall remain to be reinstated for more than **Seven days**.

12. Around the junction and ADP Boxes, signals, etc., large number of cables are laid due to which frequent excavation by concerned utility agency is observed; may be due to granting of additional connections, faults, etc which just do not cause inconvenience to the Municipal Corporation and citizens but also to the utility itself. Therefore, to avoid frequent excavation the utility shall be insisted to construct a duct around such boxes and locations.

Part D- Street Lighting

In case of cable laying or for repairing of faults for street light & signal works, the procedure for issuance of permit, preparation of estimate and reinstatement shall be as per instructions issued hereinabove, except that Demand Note is not be issued as the reinstatement will be carried out at the cost of Municipal Corporation.

1. The Fund required for reinstatement should be provided by Chief Engineer (Roads), therefore, for noting and booking of liability, the estimate prepared excluding water supply, sewerage & supervision charges by Ward office shall be sent to Executive Engineer (Traffic & Co-Ordination) who shall note the liability and send it to be the concerned Accounts Officer for booking liability.

2. On booking the liability; Accounts Officer should send it to ward for issuing permit to the Utility and work order to the Ward trench contractor

3. In this case since we are not taking deposit from the utility, penalties shall be recovered from the same Utility undertaking trench elsewhere for providing their services.

Part E-For Municipal Utilities

The procedures mentioned in these guidelines shall also be followed for laying of services/pipelines by the Municipal Utility agencies except for the following:-

Since Municipal water and sewerage lines are required to be laid at the deeper level, time period required for completion is more. However, reinstatement shall be as per revised methodology/rates by incorporating provision in the tender. For deeper trenches, granular filling below road crust shall be restricted to 5 layers each being of 150 MM thickness; over well compacted back filled earth/materials.

For departmental works taken up by H.E. Department and sewerage project department, reinstatement of trenches shall be carried out on the lines of methodology explained in these guidelines. Provision for reinstatement of the trenches shall be made in the tenders of respective departments.

Part F- Horizontal Directional Drilling (HDD) Method of Trenching

In Mumbai city and suburbs, conventionally, the cables, wires, conduits & other services of various external and internal utilities are laid under the roads by open cut trenching method. The open cut method has its inherent disadvantages and shortcomings. Several times newly laid out roads have to be dug up. Then; the reinstated trenches settle unevenly leading to road maintenance issues and inconvenience to traffic. The reinstated trenches create longitudinal permanent weak fault lines. Open cut trenching is disruptive method. Delay in reinstating open cut trenches leads to further inconvenience. Open cut trenching can be carried out only during fair season.

Horizontal Direction Drilling (HDD) is a no-dig or minimal digging trenching technology for laying underground utilities, especially, for those services which can be laid through ducts or conduits. On account of its advantages over open cut trenching; MCGM has adopted policy to encourage use of HDD for laying underground services and restrict open cut trenching to only those situations where HDD is not feasible. In case of OFCs; invariably HDD method has to be allowed unless the concerned AC of ward/divisional Dy Chief Engineer (Road) is convinced that HDD in the particular case is not feasible owing to site constraints.

While proposing to lay/laying utility services by adopting HDD method, following policy guidelines/conditions shall be followed.

1. In case of laying of Optic Fiber Cables (OFC), necessary permission for laying optical Fiber cable network under roads in Mumbai city and suburban Areas shall be obtained by the utility company from Director of Information Technology, Government of

Maharashtra and same shall be submitted to Chief Engineer (Roads & Traffic)/concerned Asst Commissioners of ward in whose jurisdiction the work is proposed.

2. Prior to starting HDD work; for detection of existing underground utilities; the HDD applicant will have to carry out GPR/Sub Soil utility (SSU) survey of the route along which the HDD ducts are proposed. The survey data of utilities so collected through GPR survey shall be submitted to MCGM while making application for HDD permission, in GIS layers showing clearly the alignment and depth of the existing underground utilities with geo-coordinates to concerned Deputy Chief Engineer (Roads) as well as to the concerned Asst Commissioner to whom the application has been made. The principal purpose of carrying out GPR survey in advance is to ascertain exact locations, alignments etc of existing underground utility services so as to take adequate care & precautions not to damage the same while carrying out the proposed HDD work.

Such survey shall also be carried out by HDD applicant after completion of its HDD work, clearly showing the laid duct therein with Geo-coordinates and shall be submitted to concerned ward/Deputy Chief Engineer (Roads).

3. Reinstatement charges for HDD:

Considering minimum area of pit as $2M \times 2M \times 1.5M$ or actual measurement of pit proposed by the Utility agency in its application; whichever is larger shall be considered to arrive at reinstatement charges. Considering 50% of pit area as possible spill over area, reinstatement charges shall be worked out by using suitable multiplying factor and flat rate mentioned in **Annexure A**. On this RI Charges, after adding 15% supervision charges, total 115% shall be recovered from HDD applicant. If it is decided to grant the permission, concerned agency will be asked to deposit 115% of the reinstatement cost. After completion of work; once the work is certified by the Road Engineer, 90% of the reinstatement cost shall be released. 10% of the reinstatement charges will be kept with MCGM for two years duration of Defect liability period as assurance amount that the agency will carry out the repairs if the trenches settle. If the agency does not carry out the repairs to settled trenches, same shall be carried out through ward trenches contractor and the expenses shall be recovered through from the concerned agency from its withheld amount of 10%. The 15% charges out of total 115% recovered as RI charges will be kept with MCGM as supervision charges. In case the utility fails to carry out reinstatement after trenching work is over or is delayed

beyond the period prescribed by Assistant Commissioner, whole deposit shall be forfeited and work shall be executed by Assistant Commissioner through ward trenches contractor and concerned utility company shall be blacklisted.

A separate security deposit amounting to Rs 15 lacs per KM shall be recovered from the HDD applicant before issue of permit for HDD work. The said deposit shall be utilized by MCGM if in case the HDD applicant fails to restore/rectify the services of its own or other utility agencies damaged by it during course of carrying out HDD work within three days of receipt of intimation or immediately upon notice of such damage caused during course of carrying out HDD work. In case of damages to MCGM services e.g. water lines, sewers, sewer laterals etc; twice the expenses incurred on rectification of such damages shall be recovered from the security deposit. If no such eventualities occur during course of work, such deposit of Rs1500000/- per KM recovered from the HDD agency shall be returned forthwith by retaining 10% amount; which shall be refunded at the end of defect liability period of two years from the date of actual completion of HDD work.

4. NOC from Traffic Police shall be obtained beforehand by the agency. Intimation of the proposed HDD work shall be given to other all concerned MCGM as well as external utility agencies.

5. All the excavated pits/areas shall be securely barricaded to ensure that the open pits do not pose safety hazard to passersby/commuters/pedestrians/vehicles etc. Enough number of security guards/traffic wardens shall be deployed on site. For HDD work being carried out during the monsoon months, additional safety precautions as may be necessary on account of emergent situation will have to be taken by the utility agency to avoid any untoward incident.

6. Execution plan based on Bar Charts/Gantt charts for the proposed work shall be submitted by the agency to concerned ward office/ concerned Deputy Chief Engineer (Roads). The work shall be carried out as per the said plan submitted by the Utility agency.

7. Execution plan based on Bar Charts/Gantt charts submitted by utility shall be strictly followed. Fortnightly progress report shall be submitted to Astt Commissioner/Deputy

Chief Engineer (Roads). The entire work of laying utility including reinstatement of trenches shall be completed by stipulated date.

8. That the defects, if any, in the reinstatement shall be rectified by utility agency at its own cost during the defect liability period of reinstatement of two years irrespective of category of road surface.

9. That in case of default by the agency in reinstatement or in rectifications during defect liability period, the work shall be got done at the risk and cost of the HDD applicant and such expenses incurred shall be recovered from their deposits. In case of shortfall, the utility agency will have to pay the difference within 15 days of demand raised; failing which further permissions to such defaulting agencies will be withheld.

10. Pits of appropriate size (Maximum 2m X 2m x 1.5m depth) shall be excavated in the roads where optical Fiber cables are to be laid at a distance of approximately every 80 to 100M. The depth of laying the ducts shall be approximately up to 4 M below the road crust except where obstruction is met with cross utilities. The reinstatement of the pits so excavated shall be done by the HDD applicant in existing type of surface treatment under Municipal Supervision and as per Municipal specification. The HDD applicant shall make proper arrangement for access control of the chambers to avoid misuse / illegal use of ducts and chambers.

11. The pits shall be refilled exclusively with granular material and shall be compacted as per the Municipal specifications.

12. The pits/Trenches taken shall be reinstated within 48 hours after the work at that location is over, failing which, penalty as applicable as prescribed under these guidelines will be applicable.

13. The HDD applicant shall lay the number of ducts under the roads for which permission is granted by DIT, Government and Chief Engineer (Roads & Traffic)/Astt Commissioner of ward. Under the same permission; one additional duct shall be laid by the Utility agency free of cost for the dedicated use of MCGM on the road suggested by Chief Engineer (Roads & Traffic)/Astt Commissioner of ward for length equal to 30% of total length permitted or total length of the road where such duct is proposed to be

laid; whichever is more. Size of duct for MCGM shall not be less than size of largest duct laid by the HDD applicant under the relevant permission. The duct which will be laid for MCGM shall be color coded preferably yellow or as suggested by Chief Engineer (Roads & Traffic)/Astt Commissioner of ward. After completion of the said additional duct; it shall be handed over to MCGM in neat, through and through clean and clear state to concerned Astt Engineer (Maint) of the ward. The MCGM duct will be allotted by MCGM to any other operator/party at the sole discretion of the Municipal Commissioner. The HDD applicant shall maintain the MCGM duct free of cost, till its allotment by MCGM to another operator.

Laying of additional duct for MCGM will not be insisted if the total length of duct to be laid through HDD by the applicant is less than 100 M or the same is only to establish connectivity or to provide new connections to the customers on existing line or for replacement of existing duct.

14. No damage shall be caused to existing underground utilities; pertaining to MCGM or other external Agencies; while laying the conduits by using Horizontal Directional Drilling Methodology. In case any other utility is damaged, the damage so caused, shall be made good by the HDD applicant at its risk & cost OR the expenses incurred by the respective utility agency towards rectification of the damages caused shall be borne by the utility agency carrying out HDD work. In addition, if negligence or absence of due diligence is observed leading to such damages, fine equivalent to twice the cost of rectification will be charged. A clause to this effect will have to be inserted in the registered undertaking to be submitted to MCGM. In case of work carried out in monsoon months, extra precautions will be taken to ensure that no damage is caused to other underground utilities.

15. If the conduits/OFCs laid by HDD methods by any agency along any road are required to be shifted in future on account of requirement of Municipal projects; same shall done by the HDD applicant entirely at its risk and cost. No compensation will be entertained on this account. Instructions of MCGM in this respect shall be complied with in the prescribed time frame. A clause to this effect will have to be inserted in the registered undertaking to be submitted to MCGM.

16. MCGM will not be responsible for any damage to OFC and resultant losses if any, due to any act of employee of Government of Maharashtra, MCGM, while performing official duties.

17. Utility Company shall submit registered undertaking on Rs200/- stamp paper to Astt Commissioner of concerned ward office and to Deputy Chief Engineer (Roads) if the proposed work is along ongoing project roads or along roads under defect liability of Chief Engineer (Roads & Traffic) for faithful compliance of all the relevant conditions mentioned herein, along with application seeking permission to carry out HDD work, with details of works and roads mentioned therein; in per the format as enclosed in **ANNEXURE G & H.**

18. Before commencing the HDD work as permitted by MCGM; the concerned Utility agency shall inform all other related utility agencies such as "Tata Power Limited/B.E.S.T./Reliance Energy/MGL/HE/SO well in advance about the proposed work. Joint survey shall be conducted by these agencies & tentative cable/utility location shall be informed to "HDD" execution team along route map of their cable/utility laid. In case location of any utility/cable or their route is not traceable/not known, a representative of that utility agency shall be posted at site while the HDD work is carried out at the location. List of contact persons shall be shared with above utilities by agency executing "HDD" work.

19. Work may be allowed during dry spells of monsoons subject to obtaining specific permission from Traffic Police Department. No work shall be carried out during rains.

20. During the period of "Ganapati Festival" and two days prior to Ganapati Festival, (about 12 days) and certain sensitive/critical days so declared by MCGM/Police/GOM, HDD work shall not be carried out. Two days before start of "Ganapati Festival", excavated pits shall be reinstated as per MCGM specifications. During this period, all roads shall be cleared of any kind of obstructions, debris, including removal of machinery etc.

Part G Micro Trenching

Micro Trenching is the least invasive and least disruptive advanced trench technology method where a trench of about 50MM width and maximum depth 450MM is saw cut in the road carriageway by cutting wheels of automated machines. It is

advanced method of laying OFCs either in a miniature duct or as inset in an inlaid. Simultaneous to the micro-trenching work, OFCs are laid through a conduit and immediately thereafter the miniature trench is reinstated by the respective agency in approved Sealant and the top 40 MM layer is reinstated in bituminous material.

Micro-Trenching work will not be allowed in CC road carriageway. For Micro-Trench work; concerned Astt Commissioner of ward shall invariably obtain NOC of divisional Dy Engineer (Roads) who in turn shall issue such NOC after obtaining approval of Chief Engineer (Roads & Traffic) irrespective of the road being minor, major, within or outside defect liability period of Roads department

While making an application for micro trench, along with the application, the agency will have to submit the explicit details of material to be used for reinstatement and submit estimate of reinstatement work to the respective ward. AE (Maint) of ward shall scrutinize the methodology of reinstatement and if it is found workable; shall allow the agency to carry out micro trench work and it's reinstatement with the proposed material. As the reinstatement will be carried out by the agency itself, only 15% supervision charges on reinstatement amount shall be recovered. A security deposit of Rs 500000/- per KM shall be recovered from the agency to ensure that unforeseeable damages caused during course of micro trench work are rectified by the agency immediately. 90% amount of this deposit shall be released immediately after satisfactory completion of reinstatement of Micro-Trench work satisfactorily. If any service of any utility agency is damaged during course of Micro-Trench work, it shall be made good by the agency carrying out the Micro-Trench work and if the agency fails to do so or in case of delay in rectifying such damages; it shall be carried out by the respective external agency in case of the damage to its services and by MCGM in case of damages to its own services. Expenses incurred on this account shall be recovered from the micro-trench agency through the balance 10% deposit. For any shortfall, demand shall be raised and the Micro-trench agency shall pay the charges within fifteen days of such demand. In case of default, the agency shall be blacklisted. In other case, the 10% deposit shall be retained with MCGM till expiry of two years defect liability period. Such retained deposit shall be released after completion of defect liability period which will be two years from date of completion of work.

This method has the advantage over conventional trenching in the manner that roads are not dug up for days altogether leading to disruption of normal traffic and inconvenience to public in general. Chances of settlement of reinstated trenches are remote hence lesser consequent maintenance related troubles. However, Micro

Trenching method has its own inherent disadvantages. The OFC conduit being laid at a shallow depth of 300MM to 450MM, is highly prone to getting damaged if other agencies e.g. Power cable laying agencies or MCGM departments like HE, Sewerage Department or Sewerage Operations etc undertake open cut excavations/Micro tunneling works along the alignment of the Micro Trench. So in case of a micro trench, it has to be laid as far as to the extreme edge of the road where possibilities of excavations for open cut methods are relatively less. However, when reconstruction of road is undertaken by MCGM, the OFCs laid through micro trench will get invariably damaged.

In view of such circumstances, the onus of protecting the OFCs laid through Micro Trenches naturally rests with the respective agency which has laid the OFCs through Micro Trench. As the depth of the OFCs laid through micro trench is shallower and as presently most of the underground services laying is carried out through either open cut method or to some extent by HDD and as the services which are laid through these methods are laid at deeper levels underground, such agencies cannot be held responsible for obvious reasons for damages to the OFCs laid through Micro Trench.

The agency which lays the OFC conduits through Micro Trenches has to exercise utmost care to ensure safety of its services and guard its services through manning. It has to coordinate with all the service laying agencies, AE (Maint) of ward and HE, Sewerage Project, SWD and Sewerage Operations departments of MCGM to keep track of programs of trench activities of these agencies. Whenever any other agency proposes open cut trench/HDD trench along the alignment of Micro Trench then in such case, the agency owning micro-trench services will have to remove its services and lay the same again through Micro Trench; once the laying of utility by open cut method/HDD method is completed by the another agency. In such cases, the agency will not again be required to pay the 15% supervision charges.

As the services laid through Micro Trench are at shallow depth hence are vulnerable to damages; therefore responsibility of guarding such services lies with the parent agency. Hence for any damages caused to such services by other agencies cannot be a cause for claiming compensation. While granting permission to the Micro Trench agency, such condition shall be put in the permit as well as such a registered undertaking cum indemnity bond on Rs 200/- stamp paper stating that the agency agrees to all the relevant conditions shall be obtained from the utility agency. This method shall be allowed only as last mile connectivity where laying of cables through open cut or HDD method is not possible.

While issuing permit for micro trench; following points shall be stressed.

- The agency shall follow the safety guidelines, barricading etc. as prescribed in the circular issued by MCGM under no MGC/F/1835 of 17.11.2007 and as per Annexure 11.
- The agency shall submit and carry out the work as per work execution plan submitted by it. The entire work including reinstatement of trenches shall be completed by stipulated date.
- The micro trenches shall be reinstated within 48 hours after the work at that location is over, failing which, penalty of Rs 500 per Meter per day will be imposed and will be recovered through the security deposit. In case of shortfall, until such excess amount of penalty is deposited by the agency with MCGM; further permissions for laying cables; be it through open cut excavation, HDD or Micro Trench method will not be granted.
- If damage occurs to the Micro-trench duct /OFC in future due to excavation of trench or due to any other activity by municipal or external utility, the same shall be restored by the agency which has laid OFCs through Micro trench at risk and cost of it as the duct is at shallower depth and so is vulnerable to damages.
- That the security deposit of Rs 5,00,000/- per KM shall be deposited by the agency in concerned ward. That, 90% of the deposit will be refunded if completion of Reinstatement work is carried out satisfactorily and without causing damages to other utilities. The remaining 10% amount will be refunded after completion of the defect liability period. The defect liability period will be 2 years. During this period, the Agency will have to make good all the defects, damages to the reinstated trench at its own cost.
- That in case of default in reinstatement of micro trench or rectifications during defect liability period, the work will be got done at risk and cost of the agency and the expenses will be recovered from its deposits and/or additional payments in case of shortfall shall be deposited by it with MCGM on demand.
- That the N.O.C. from Traffic Police shall be obtained and the conditions thereof shall be binding upon the agency.
- Micro trenches of maximum size; up to width 50 mm x 450 mm depth shall be saw cut along roads where Optical Fiber cables are to be laid as last mile connectivity to reach the end consumers including construction of Manholes at every 100 M intervals.
- For detection of existing underground utilities; the agency will have to carry out GPR survey before taking up the micro trench work along the route where the

ducts are proposed to be laid. The data of utilities so collected through GPR survey shall be submitted to MCGM on CD as well as in hard copy while making application for permit.

- No damage shall be caused to other underground utilities while laying the ducts by using micro trenching technology. In case any utility is damaged, the damage so caused to the other utilities, shall be rectified by the agency carrying out micro trench at its risk and cost. Further, suitable penalty as deemed fit will be imposed on the Micro-Trench laying utility agency by MCGM. In case the utility agencies defers the reinstatement work or fails to rectify the damages to services of other utility agencies, such work will be got carried out by MCGM at risk and cost of the said agency and such agency will be blacklisted for future works. The expenditure so incurred will be recovered from the security deposit with MCGM.
- The depth of laying the ducts shall be 300 mm to 450 mm below the road surface.
- The cost of shifting/removing the conduits/OFCs and relaying the same shall be borne by the agency that has carried out the micro trench work, whenever required and/or during execution of open cut trenches/HDD activities by other utilities. MCGM or for that matter; any other utility agency will not be responsible for any damage to OFC laid by micro-trenching and resultant losses, as the OFC ducts having been laid at shallower depth are vulnerable to damages due to open cut or HDD works.
- The agency shall submit registered undertaking cum indemnity bond on Rs200/- stamp paper to MCGM for faithful compliance of all the conditions.
- It shall make proper arrangement for access control of the chambers proposed to be constructed at every 100 M intervals to avoid misuse/ illegal use of ducts and the chambers.
- It shall be solely responsible for any mishap during execution of micro-trenching work. It shall indemnify MCGM against such mishap and its consequences.

Part H- Methods of reinstatement of trenches

- 1) After laying service cables/conduits; those shall be covered with sand layer of sufficient thickness and then it shall be covered by tiles by the Utility agency. The thickness of such sand cushioning shall be sufficient enough to withstand compaction by vibratory roller during reinstatement of the trench. This will be strictly the liability of the

Utility Agency and any claim of damages by Utility agency in this regard will not be entertained by MCGM

- 2) The reinstatement contractor shall backfill the trench with granular layers. Each layer of granular material shall not be more than 150 mm in thickness. Maximum 5 layers of granular layers shall be operated. In case of more depth of trench, depth below the thickness of maximum five granular layers shall be backfilled by excavated earth first. Sufficient watering and ramming of each layer shall be done with vibratory hammer to avoid settlement of these layers and to achieve effective compaction.
- 3) Over the layers of granular materials, further reinstatement shall be done as per as per **Annexure- C & D** and as directed.
- 4) All reinstatement work including Asphaltting shall be completed prior to 10th May of every year

Part I- Trench Tracking System

After successful implementation of online Potholes Tracking System in MCGM; which proved to be helpful to address the problem of potholes in real time and to fix up the responsibility of lapse on the particular defaulters and has thereby assisted in reducing number of unattended potholes, on similar principles, MCGM has now adopted the Trench Tracking System. The general principles of Trench Tracking System are very similar to Potholes Tracking System. Presently this system has been made applicable to only open cut trenching method for planned jobs.

Broadly the system will work on following steps.

After issue of excavation permit, concerned AE will assign the trench to concerned RE through his login id. The concerned RE will enter all the relevant details of the proposed trench in the Trench Tracking System e.g. Name of agency taking the trench, length of trench, width of trench, date of start and date of end of the trench work as per permit, existing road surface, Total reinstatement charges recovered from the agency as per demand note etc. Photos of the trench before starting the work, during progress of trench shall be uploaded by the RE in system. If the trench work is completed as per dates mentioned in permit; then next timeline event will appear. However; in case of delay or exceeding the length of trench than permitted, the RE will have to enter actual date of completion of trench work and if applicable the extra length of excavation carried out by the agency in the system. Penalty as per annexure B for delay in completion of trench will be imposed on the utility. For the excess length of trench carried out, reinstatement charges for additional length shall be recovered at the

rate of 1.5 times of the regular RI charges applicable per meter. Once the actual data is entered in system by RE, the penalty will be auto generated by system and will be added cumulatively. Depending upon the start date and end date mentioned in trench permit, the system will display name of the trench reinstatement contractor; date of start and date of end of reinstatement work. Estimate of the proposed trench work in the system shall be entered in the system by RE. Defect liability period of two years for the individual trench will commence from the completion date of reinstatement of trench.

After completion of trench work by utility agency and once the actual end date of trench by utility agency is entered by RE; the trench will be assigned to the reinstatement contractor by system for reinstatement along with the estimate of the trench. The said estimate shall be entered in the system by the RE at the time of entering actual end date of completion of trench work by utility agency. Flat seven days' time will be allowed to complete the reinstatement of trench up to 500M length. For per additional length of 200M trench reinstatement or fraction thereof, additional two days of time period will be allowed. After completion of reinstatement of trench, the reinstatement contractor shall close the trench by completing and finishing the work and by uploading photos of finished work. Thereafter the concerned ward RE shall visit the site, ascertain if the trench has been in fact attended in the manner it should have been, then he shall close the trench through his id. If the reinstatement of trench is completed by the reinstatement contractor BY or BEFORE the system assigned END date, there will be no penalty on this account. However, if the actual end date is later than the system assigned END date, then for delay beyond stipulated end date of reinstatement of trench, penalty of Rs. 5000 per day will be imposed on the contractor by the system.

The penalties mentioned in Annexure-B will be automatically imposed by the system if variation in time line of events is observed. Penalties for not providing barricades as per specifications, non-removal of debris shall be manually entered in system by the RE. Depending upon the data entered by ward RE, system will generate penalty as per annexure-B. The cumulative penalty will be recovered from the concerned underground service laying utility agency by raising a demand. After receipt of such demand, the agency shall deposit the said amount with MCGM. In case of delay or reluctance to pay the fine, no further permits shall be granted to such agencies. After seven days of raising such demand for recovery of penalty is raised by MCGM, red alert against the respective agency will be generated by the system. This alarm can be

turned off from the login of concerned ward RE; only after payment of penalty is made by the agency in the ward which has generated the penalty letter. Till such time, the Trench Tracking system will not accept details of new proposal of trenching of the said agencies.

In case settlement is observed in reinstated trench then the trench shall be re-opened and re-assigned to the reinstatement contractor who will attend the trench within 7 days. For delay beyond seven days in attending the trench, penalty of Rs 5000 per day will be imposed by the system.

Each new trench will be assigned unique identification number by the system. This will be permanent identification number of that trench till the defect liability of the trench reinstatement is over or till such earlier period when the said stretch is again excavated for trench or other purpose. Once the reinstated trench is again excavated within the defect liability period, defect liability of originally reinstated trench will cease to be in effect.

The synchronization of trench work through Trench Tracking system will help manage the data base at click of mouse. Information such as total length of trenches taken in every ward, its cumulative length for entire Mumbai, agency wise break up of trench length per ward and for Mumbai, Total reinstatement charges recovered from each ward from one as well as all agencies, amount of penalties recovered from various agencies etc. will be available immediately through system

Part G-Monitoring /reporting status of trenching activity.

It is necessary to have centralized co-operation & monitoring mechanism so as to make administration/public/traffic police aware of such activity & its status from time to time.

All Chief Engineers, ACs and H.E. are therefore required to invariably forward utility wise/ ward wise details of trenching activity in the enclosed format. Report for every month must reach the office of Chief Engineer (Roads & Traffic) by **5th of the next month.**

No other Municipal agency shall issue any circular in this regard without referring to this circular and with the specific sanction of Municipal Commissioner.

**MUNICIPAL CORPORATION OF GREATER MUMBAI
SCHEDULE OF FLAT RATE**

A) ON FOOTPATH

Sr. No.	Existing Surface	Finished to	Rate in Rs. per Rmt.
1	Any surface	Lacquered coated coloured paver blocks (60 mm thick)	10381.00
2	Any surface	Concrete finished	10088.00
3	Any surface	Gray or any specified colour with shot Blasted Texture paver blocks (200X200X60mm)	11264.00

B) ON CARRIAGEWAY

Sr. No.	Existing Surface	Finished to	Rate in Rs. per Rmt.
1	Cement Concrete Carriageway	A) 100 mm thick Paver block immediately B) Cement Concrete Pavement in due course	21268.00
2	TWT Carriageway	A) 100 mm thick Paver block immediately B) Cement Concrete Pavement in due course	14774.00
3	Mastic Asphalt 25 mm thick	Mastic Asphalt 25 mm thick	11151.00
4	Mastic Asphalt 40 mm thick	Mastic Asphalt 40 mm thick	12268.00
5	Bituminous concrete (30/40 grade)	Bituminous concrete (30/40 grade)	11080.00
6	Paver blocks 80mm thick (50% Grey & 50% Red Paver Blocks)	Paver blocks 80mm thick (50% Grey & 50% Red Paver Blocks)	8974.00
7	Paver blocks 80mm thick (Only Grey colour)	Paver blocks 80mm thick (Only Grey colour)	8800.00

8	Paver blocks 100mm thick (50% Grey &50% Red Paver Blocks)	Paver blocks 100mm thick (50% Grey &50% Red Paver Blocks)	9430.00
9	Paver blocks 100mm thick (Only Grey colour)	Paver blocks 100mm thick (Only Grey colour)	9296.00

C) Use of existing duct Rs. 2100/- per meter

D) Multiplying factor vis-a-vis Defect Liability Period

Sr.No.	Item	5 Years	3 Years
1	Excavation during first year of Defect Liability Period	4.0	4
2	Excavation during Second year of Defect Liability Period	3	3
3	Excavation during third year of Defect Liability Period	2	2
4	Excavation during fourth ear of Defect Liability Period	1.7	---
5	Excavation during fifth year of Defect Liability Period	1.4	---
6	Excavation beyond Defect Liability Period	1.0	1.0

Note:1)The above flat rates are calculated on the basis of Unified Schedule of Rates (SOR) 2013 effective from 16.09.2013.

2)The flat rates are subject to revision in accordance with revision of fair market rate schedule.

SCHEDULE OF PENALTIES

Schedule of Penalties to be recovered from Utility/Ward CWC for various lapses observed during the excavation and reinstatement of trenches.

(A) For Utility and reinstatement contractor.

Sr No	Particulars	Penalty in Rs	Per
1	Delay in starting	10000	Day
2	Delay in Completion up-to 2 days	5000	Day
3	Delay in completion by more than 2 days and up-to 5 days.	10000	Day
4	Delay in Completion more than 5 days	15000	Day
5	Delay in completion phase wise.	5000	Day
6	Non-availability of Engineer in charge.	5000	Day
7	Non-fixing of Barricading	1000	Meter/Day
8	Not providing reflector signage	2000	Number
9	Non-Displaying board	2000	Number
10	Non-Appointing of warden	2000	Day
11	Not providing M.S. plate for crossing	5000	Day
12	Non-removal of excavated earth in time	10000	Day
13	Failing in removal of excavated earth	25000	Lump Sum
14	Transporting the excavated earth to other spot than instructed by Engineer	20000	Lump sum
15	Non-covering of water entrance	5000	Each
16	Non-cleaning of water entrance	5000	Each
17	Damages to Municipal Utility	Actual cost	
18	Damages to other utilities	Actual Cost	
19	Damages to private property	Actual cost.	
20	Not providing night lighting	1000	Meter

(B) – For Utility Agency

Sr. No.	Particular.	Penalty in Rs.	Per
1	Increase in length than permitted	RI charges for excess length shall be recovered @ 1.5 times of the applicable RI charges	
2	Change in alignment Lump Sum.	25000	Lump sum
3	Change in Starting point	10000	Each
4	Change in end point	10000	Each
5	Not providing of missing cover.	25000	Each
6	Even though alternative arrangement is established taking excavation under the guise of fault repairs.	25000	Each

(C) – For reinstatement contractor.

Sr. No.	Particular.	Penalty in Rs.	Per
1	Not rolling and compacting as per specification	2500	Meter
	Delay in reinstatement of trench beyond end date	5000	Day
2	Not attending damaged trench during defect liability period; within 7 days from the date of reopening & reassignment of trench	5000	Day
4	Attending damaged trench through other Agency after 7 days during guarantee period.	Actual cost at his risk and cost.	

Note: Wherever unit is mentioned as metre it shall be taken with reference to length of trench.

Typical Cross Section of Trench For Reinstatement On Footpath/ Passage

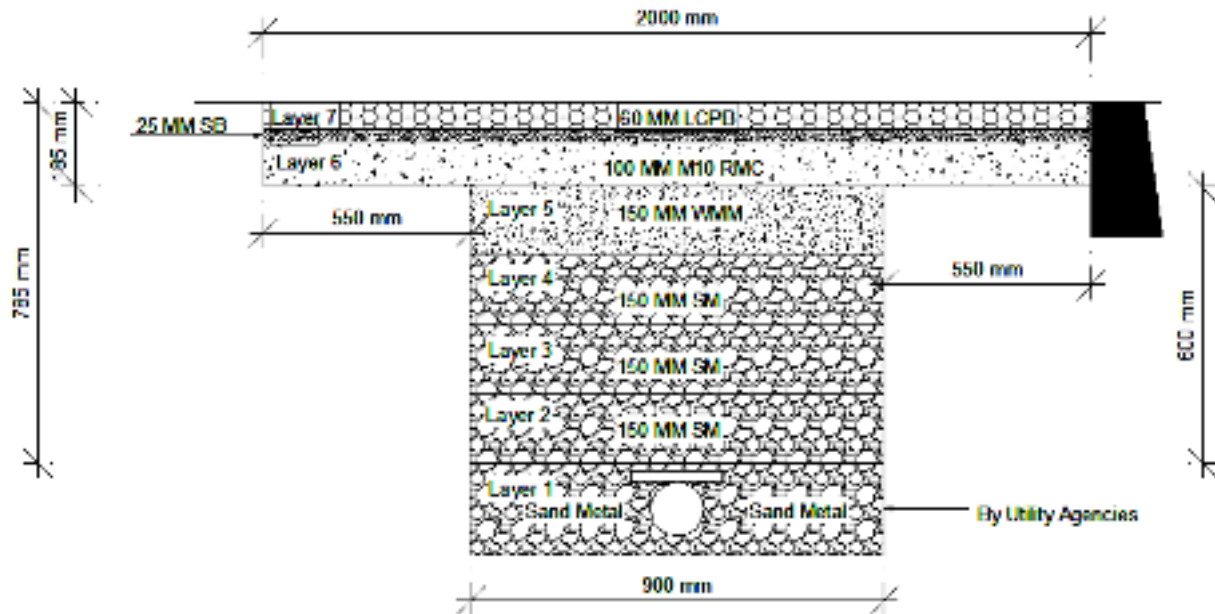

Layer No.	SOR 2013 Item No.	Description of Material	Remarks
Layer 1	--	Sand metal	Sufficient watering & ramming by Utility
Layer 2	RW-10-28	Sand metal	Sufficient watering & ramming by Reinstatement contractor
Layer 3	RW-10-28	Sand metal	Sufficient watering & ramming by Reinstatement contractor
Layer 4	RW-10-28	Sand metal	Sufficient watering & ramming by Reinstatement contractor
Layer 5	RW-2-20	Wet mix macadam	Compaction by 10 Tons Vibratory roller
Layer 6	RW-10-27	RMC M-10	Curing of M-10 PCC
Layer 7	--	Sand Cushioning	--
Layer 8	RW-3-17 & RW-3-14	60 mm thick lacquer coated paver blocks	--

- Note:**
- 1) The thickness and number of Layers of Sand metal filling will depend on proposed depth of excavation as per application from Utility (Annexure-I)
 - 2) The maximum thickness of each layer of Sand metal shall not be exceed 150 mm.
 - 3) Vibratory roller shall be used for compaction of each layer of road crust.

Typical Cross Section of Trench for Reinstatement on Asphalt Road

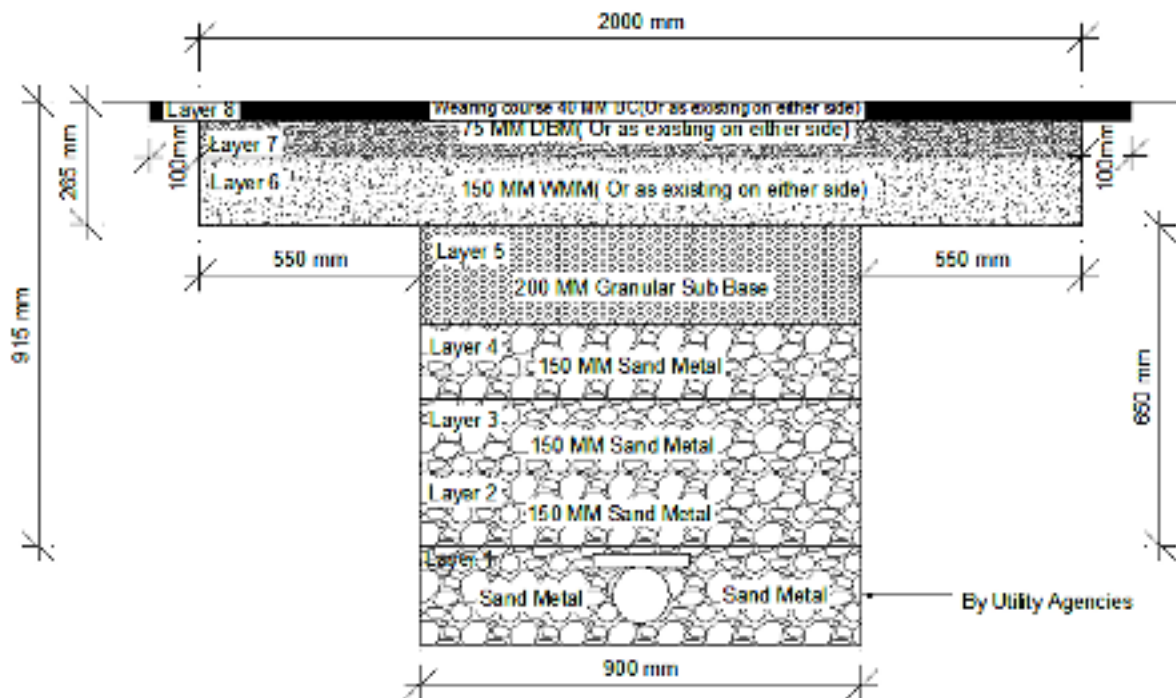

Layer wise details for item / materials to be used & its compaction.

Layer No.	SOR 2013 Item No.	Description of Material	Remarks
Layer 1	--	Sand metal	Sufficient watering & ramming by Utility
Layer 2	RW-10-28	Sand metal	Sufficient watering & ramming by Reinstatement contractor
Layer 3	RW-10-28	Sand metal	Sufficient watering & ramming by Reinstatement contractor
Layer 4	RW-10-28	Sand metal	Sufficient watering & ramming by Reinstatement contractor
Layer 5	RW-2-21	Granular subbase	Compaction by 10 Tons Vibratory roller
Layer 6	RW-2-20	Wet mix macadam	Compaction by 10 Tons Vibratory roller
Layer 7	RW-5-45	Premix dense bituminous macadam	Laying by sensor paver & compaction by 10 Tons vibratory roller
Layer 8	RW-5-40	Premix bituminous concrete	Laying by sensor paver & compaction by 10 Tons vibratory roller

- Note:**
- 1) The thickness and number of Layers of Sand metal filling will depend on proposed depth of excavation as per application from Utility (Annexure-I)
 - 2) The maximum thickness of each layer of Sand metal shall not be exceed 150 mm.
 - 3) Vibratory roller shall be used for compaction of each layer of road crust.
 - 4) For deeper trenches for internal department of MCGM, sand metal filling below road crust may be restricted to maximum 05 layers (each of 150 mm thickness) over well compacted backfilled earth materials.

MUNICIPAL CORPORATION OF GREATER MUMBAI

SAMPLE ESTIMATE FOR REINSTATEMENT OF TRENCHES IN 60MM THICK LACQUER COATED PAVER BLOCKS IN FOOTPATH CONSIDERING 2.00M WIDTH, 10M LENGTH, 0.785M DEPTH & 0.90M WIDTH OF TRENCH

Dimensions in mtr.

1	Length of Footpath	10.000
2	Width of the Footpath	2.000
3	Thickness of PCC M10	0.100
4	Thickness of WMM Layer	0.150
5	Thickness of Cushioning Sand	0.025
6	Thickness of Paver Blocks	0.060
7	Thickness of Sand Metal	0.450
8	Total Depth of excavation	0.785
9	Excavation depth in Asphalt	0.185
10	Width of Trench	0.900

NO.	ITEM NO.	DESCRIPTION OF ITEM	NO.	LENGTH IN mtr.	WIDTH IN mtr.	DEPTH IN mtr.	QTY.
1	CS-EW-1	Excavation for foundations, substructures, basements, tanks, sumps, walls, chambers, manholes, trenches, poles, pits & general building works in all types of soils, vegetable earth, etc. complete.					
		Trench	1.00	10.00	0.90	0.785	7.07
							Cum
2	CS-EW-3	Excavation for foundation, substructures, basements, tanks, sumps, walls, chambers, manholes, trenches, poles, pits & general building works in soft/disintegrated rock, sandstone, stiffclay, gravel, cobble stone, hard laterite, water bound macadam, wet mix macadam, asphalt mix carpet .Complete					
		Crust	1.00	10.000	1.100	0.185	2.04
							Cum
3	RW-1-18	Levelling, watering & rolling by vibratory roller IDD-22 weighing not less than 10 tonnes & preparing the ground to the required grade & camber (only to be used for reinstatement for trench in road work) as per New Road Specifications.					
			1.00	10.000	1.100		11.00
							SQM

4	RW-10-27	P/LR.M.C.M-10C.C .having avg. compressive strength 13.5 Mpa grade in foundation /encasemen /pavement with or without chequered design including formwork,mixing in batching plant,placing vibrating with plate or needle curing etc.complete as directed by the Engineer.C/s.has to make his own arrangement for water for curing with Hessian cloth etc.& will not be paid separately. (MINIMUM CEMNT CONTENT 220 Kg/m³.)					
			1.00	10.000	2.000	0.100	2.00
							Cum
5	RW-2-20	Providing & laying, spreading & compacting graded crushed stone aggregate to wet mix macadam satisfaction including premixing the material with water to OMC in mechanical mix(pugmill) carriage of mix material by tipper to site laying in uniform layer of 75mm to 100mm etc. complete.					
			1.00	10.00	0.90	0.150	1.35
							Cum
6	RW-3-17	Providing & fixing in the footpath, 60mm thick Lacquer coated (Reflective) interlocking gray cement concrete paver sinred (Terra Cotta) Black, Brown, Lemon Yellow or any colour with vermeticular or any anti skid texture on top surface of Approved pattern/ shape and colour having average crusting strength 40N/mm² manufactured in double layer precast concrete blocks. The top layer of paver block should be 12 to 15mm thick and consist cubical shape stone aggregate 8mm size sieve 100% passing and retain on 4.75mm size sieve, silic as and with pure ironoxide ultravoilete stabilized pigment @ 5% by weight of cement and should be coated with lacquer having hard, high abrasiveresistance and water repellent. The bottom layer should be 45 to 48mm thick having 12mm size sieve 100% passing aggregate as per technical specification placed on uniformly grade drivers and cushioning of average compacted thickness 25mm properly comacted with mechanical compact or with required level, grade and camber etc. complete as specified and as directed by the Engineer.					
		(Considering new paver blocks in trench)	1.00	10.000	0.900		9.00
							SQM

7	RW-3-14	Removing & refixing interlocking concrete pavers of 60 mm thick, having of any size, shape and colour considering 10% breakage area of pver block while removing same from position and replaced same by new paver blocks having average crushing strength not less than 40 N/mm ² placed on uniformly graded river sand cushioning of average compacted thickness 25 mm properly compacted with mechanical compactor with required level, grade and camber etc. complete as specified and as directed by the Engineer.					
			1	10.00	1.10		11.00
							Rmt.
8	RW-7-51	P/f Polyethylene plastic water/sand fillable Barricades having approx. size 2000mm. X 560mm. X 1000 mm., (LxWxD), 20-23 Kgs empty wt. and tank capacity 80-100 lits., manufactured by M/s. B.D. Industries or equivalent ISO Certified Company having minimum experience of 3 years in manufacturing and supplying to the Govt./Semi Govt./Other reputed organisations alongwith necessary fixing and interlocking arrangement as specified and directed by the Engineer Incharge.					
			2	2.00			4.00
							Rmt.
9	RW-7-50	P/f Polyethylene plastic water/sand fillable Metro Barricades having approx. size 1840mm. X 440mm. X 1900mm., (LxWxD), 32-35 Kgs empty wt.and tank capacity 100-120 lits., manufactured by M/s. B.D. Industries or equivalent ISO Certified Company having minimum experience of 3 years in manufacturing and supplying to the Govt./Semi Govt./Other reputed organisations alongwith necessary fixing arrangement as specified and directed by the Engineer Incharge					
			2	11.00			22.00
							Rmt.
10	RW-10.28	Supply & filling sand, metal GRAVELLY SAND Corresponded to CLASS II/ CLASS III GRADING of TABLE 100.1of new road specifications-2006 in trenches upto required depth & watering, ramming etc. complete as directed					
			1.00	10.000	0.900	0.450	4.05
							Cum
11	RW-2-22	Rebate for not using motor grader / paver for laying of Granular Sub base in RW-2-21					
		Same as item no 5					1.35
							Cum

12	C.S-EW-8	Add for lead upto 3 km including levelling. Note: Prior Specific sanction of Head of Dept. should be taken if transportation is to be done at night for above items, (i.e. between 8.00pm. to 6am.) and the rate shall be reduced by 10%. This item will be operated/executed with the specific sanction of the Chief Engineer					9.10
							Cum
13	C.S EW-9	Add for each additional lead of 1km beyond initial lead of 3km including (for additional 22 km) levelling. Note: Prior Specific sanction of Head of Dept. should be taken if transportation is to be done at night for above items, (i.e. between 8.00pm. to 6am.) and the rate shall be reduced by 10%. This item will be operated/executed with the specific sanction of the Chief Engineer					200.20
							Cum
14	RW-10-60	Providing and fixing of the precast kerb stone of height 325mm., base width 165mm., top width 115mm. in M20 grade RMC supplied through MCGM approved plant or concrete mixed with use of weigh batch mixer as detailed in drawing u/No. DyCh.E. /Rds/93 /E.S. of 17 / 8 / 2005 , excavation in any soil except rock, laying a leveling course of M 15 grade RMC 100mm. thick, to required slope (inclusive of form work) jointing in C.M. 1:2 proportion flush to concrete surface, painting exposed surface with one coat of primer and two coats of 1st grade road marking paint in the yellow/white/black or any shade as directed. (Kerbstones shall be procured from MCGM registered agencies).					
			1	10.00			10.00
							Rmt.

Note: 1) The sample estimate is as per unified schedule of rates effective from 16.09.2013
2) Actual estimate shall however be prepared by adopting items and rates applicable as per prevailing contract of the reinstating agency.

ANNEXURE -F

MUNICIPAL CORPORATION OF GREATER MUMBAI

SAMPLE ESTIMATE FOR REINSTATEMENT OF TRENCHES IN 40MM THICK BC CARRIAGEWAY CONSIDERING 2.00M WIDTH, 10M LENGTH, 0.915M DEPTH & 0.90M WIDTH OF TRENCH

Dimensions in mtr.

1	Length of road	10.000
2	Width of the road	2.000
3	Thickness of AC Layer	0.040
4	Thickness of DBM layer	0.075
5	Thickness of GSB Layer	0.200
6	Thickness of WMM Layer	0.150
7	Thickness of Sand Metal	0.450
8	Total Depth of excavation	0.915
9	Excavation depth in Asphalt	0.265
10	Width of Trench	0.900

NO.	ITEM NO.	DESCRIPTION OF ITEM	NO.	LENGTH IN mtr.	WIDTH IN mtr.	DEPTH IN mtr.	QTY.
1	CS-EW-1	Excavation for foundations, substructures, basements, tanks, sumps, walls, chambers, manholes, trenches, poles, pits & general building works in all types of soils, vegetable earth, etc. complete					
		Trench	1.00	10.00	0.90	0.915	8.24
							Cum
2	CS-EW-3	Excavation for foundation, substructures, basements, tanks, sumps, walls, chambers, manholes, trenches, poles, pits & general building works in soft/ disintegrated rock, sandstone, stiff clay, gravel, cobble stone, hard laterite, water bound macadam, wet mix macadam, asphalt mix carpet .Complete					
		Crust	1.00	10.000	1.100	0.265	2.92
							Cum
3	RW-1-18	Levelling, watering & rolling by vibratory roller IDD-22 weighing not less than 10 tonnes & preparing the ground to the required grade & camber (only to be used for reinstatement for trench in road work) as per New Road Specifications.					
			1.00	10.000	1.100		11.00
							Sqm
4	RW-2-21	Providing & laying, spreading & compacting specified crushed stone in granular sub base course including premixing the material in mechanical mixer (pug mill or approved type), spreading of mixed material in uniform layer of 100 mm to 75mm etc. complete					
			1.00	10.000	0.900	0.200	1.80
							Cum

5	RW-2-20	Providing & laying, spreading & compacting graded crushed stone aggregate to wet mix macadam satisfaction including premixing the material with water to OMC in mechanical mix(pug mill) carriage of mix material by tipper to site laying in uniform layer of 75mm to 100mm etc. complete					
			1.00	10.000	2.000	0.150	3.00
							Cum
6	RW-5-20	Providing and applying PRIME COAT with CATIONIC BITUMEN EMULSION (SS)@7 to 12Kg. Of 10 Sqmt. Etc complete					
			1.00	10.000	2.000		20.00
							Sqm
7	RW-5-23	Providing and applying TACK COAT with CATIONIC BITUMEN EMULSION (RS) @ 0.2 to 0.25 Kg. per sqm.					
		On DBM	1.00	10.000	2.200		22.00
							Sqm
8	RW-5-24	Providing and applying TACK COAT with CATIONIC BITUMEN EMULSION (RS) @ 0.25 to 0.30 Kg					
		On WMM	1.00	10.000	2.000		20.00
							Sqm
9	RW-5-45	P/L hot Premix Dense bituminous macadam with 4.50% bitumen content of grade 30-40 to the required line,level,and camber rolling with 10/12 M.T.power, vibratory roller & sensor paver etc. complete as specified and as directed to thickness of 75 mm. with antistripping agent at 1.00%by weight of bitumen using grading II of "MORTH"(As per new Road Specification clause no.354)					
			1.00	10.000	2.000		20.00
							Sqm
10	RW-5-40	P/L hot premix Bituminous concrete with 6.00% of bitumen grade 30/40,surface coat by mix design as per MORTH to the compacted thickness of 40 mm ,using new material to the required line, level and camber rolling with power vibratory roller & sensor paver, etc.complete as specified and as directed with lime filler 5.00%by weight and antistripping agent @ 1% of bitumen by weight etc.complete.As per new Road Specification clause no.364)					
			1.00	10.000	2.200		22.00
							Sqm

11	RW-7-51	P/f Polyethylene plastic water/sand fillable Barricades having approx. size 2000mm. X 560mm. X 1000mm., (LxWxD), 20-23 Kgs empty wt. and tank capacity 80-100 lits., manufactured by M/s. B.D. Industries or equivalent ISO Certified Company having minimum experience of 3 years in manufacturing and supplying to the Govt./Semi Govt./Other reputed organisations alongwith necessary fixing and interlocking arrangement as specified and directed by the Engineer Incharge.					
			2	2.00			4.00
							Rmt.
12	RW-7-50	P/f Polyethylene plastic water/sand fillable Metro Barricades having approx. size 1840mm. X 440mm. X 1900mm., (LxWxD), 32-35 Kgs empty wt. and tank capacity 100-120 lits., manufactured by M/s. B.D. Industries or equivalent ISO Certified Company having minimum experience of 3 years in manufacturing and supplying to the Govt./Semi Govt./Other reputed organisations alongwith necessary fixing arrangement as specified and directed by the Engineer Incharge					
			2	11.00			22.00
							Rmt.
13	RW-10.28	Supply & filling sand, metal GRAVELLY SAND Corresponded to CLASS II/ CLASS III GRADING of TABLE 100.1of new road specifications-2006 in trenches upto required depth & watering, ramming etc. complete as directed					
			1.00	10.000	0.900	0.450	4.05
							Cum
14	RW-2-22	Rebate for not using motor grader / paver for laying of Granular Sub base in RW-2-21					
		Same as item no 4					1.80
							Cum
15	C.S-EW-8	Add for lead upto 3 km including levelling. Note :Prior Specific sanction of Head of Dept. should be taken if transportation is to be done at night for above items , (i.e. between 8.00pm .to 6am.) and the rate shall be reduced by 10%.This item will be operated /executed with the specific sanction of the Chief Engineer					
							11.15
							Cum
16	C.S EW-9	Add for each additional lead of 1km beyond initial lead of 3km including (for additional 22 km) levelling.Note:Prior Specific sanction of Head of Dept.should be taken if transportation is to be done at night for above items, (i.e. between 8.00 pm.to 6am.) and the rate shall be reduced by 10%.This item will be operated/ executed with the specific sanction of the Chief Engineer					
							245.30
							Cum

- Note:
- 1) The sample estimate is as per unified schedule of rates effective from 16.09.2013
 - 2) Actual estimate shall however be prepared by adopting items and rates applicable as per prevailing contract of the reinstating agency.

REGISTERED UNDERTAKING CUM INDEMNITY BOND
(On Rs 200/- stamp paper)

I Shri Age Years, resident of, working with M/s in capacity of have been authorized to sign & submit the present registered undertaking cum indemnity bond on behalf of to Municipal Corporation of Greater Mumbai in context with the application dated Submitted in Ward; for permission to lay the services of M/s through horizontal directional drilling method; along road, in ward

I hereby give undertaking that M/s will faithfully abide by the following terms and conditions in general and more particularly as spelt out in the circular u/no if the permission to lay the services along road, in ... ward is allowed to M/s

That,

1. That we have already obtained permission from Directorate of Information Technology to undertake and lay the optical fiber cable (OFC) along the routes proposed under the current application.
2. No damage will be caused to existing underground utilities; pertaining to MCGM or any other external Agency providing underground utility services; while laying the conduits by us using Horizontal Directional Drilling Methodology.
3. In case any utility is damaged in course of the HDD work permitted, the damage so caused, will be made good by us i.e. M/s at its risk & cost OR the expenses so incurred by the respective utility agency towards rectification of the damages caused will be borne by us i.e. M/s and shall be paid within 7 days of demand.
4. M/s is aware that if negligence or absence of due diligence is observed leading to such damages, fine equivalent to twice the cost of rectification will be charged by MCGM.
5. If the services laid under the current permission are required to be shifted or relocated in future on account of requirement of Municipal projects; same shall done by us i.e. the HDD applicant entirely at our risk and cost. No compensation will be claimed by us on this account. Instructions of MCGM in this respect shall be complied with in the prescribed time frame.
6. That we will lay a duct equal to maximum diameter of duct allowed to us under this permission along any road suggested by Astdt Commissioner of ward of

length equal to 30% of total length allowed under this permission or the length of the road suggested by the Astt Commissioner of ward whichever is more and handover the same to MCGM for free of cost. MCGM may itself utilize the said duct or allot it to any other agency at its sole discretion. Till the said duct is put to use, we will maintain the said duct free of cost.

I further undertake to indemnify MCGM that if any damage is caused to other underground services, we will make the good at our risk and cost and MCGM or its servants will not be held responsible for such damage. I hereby indemnify that if any legal suits or complications arise out of this permission or any damages caused to entity; we shall be wholly be responsible for it and MCGM will not be responsible for it

Authorized signatory
M/s

REGISTERED UNDERTAKING CUM INDEMNITY BOND
(On Rs 200/- stamp paper)

I Shri Age Years, resident of, working with M/s in capacity of have been authorized to sign & submit the present registered undertaking cum indemnity bond on behalf of to Municipal Corporation of Greater Mumbai in context with the application dated ... submitted in ... Ward; for permission to lay the services of M/s through micro trenching method; along road, in ward

I hereby give undertaking that M/s will faithfully abide by the following terms and conditions in general and more particularly as spelt out in the circular u/no if the permission to lay the services along road, in ... ward is allowed to M/s

That,

1. That we have already obtained permission from Directorate of Information Technology to undertake and lay the optical fiber cable (OFC) along the routes proposed under the current application.
2. No damage will be caused to existing underground utilities; pertaining to MCGM or other external Agencies; while laying the conduits by using Micro-Trench Methodology.
3. In case any other utility is damaged, the damage so caused, shall be made good by us i.e. M/s at its risk & cost OR the expenses so incurred by the respective utility agency towards rectification of the damages caused will be borne by us i.e. M/s and will be paid within 7 days of demand.
4. M/s..... is aware that if negligence or absence of due diligence is observed leading to such damages, fine equivalent to twice the cost of rectification will be charged by MCGM.
5. If the services laid under the current permission are required to be shifted OR removed and re-laid in future on account of requirement of Municipal projects; or for laying underground services of other agencies including MCGM; by open cut or HDD method; we will shift OR remove and re-lay our services free of cost at our risk. No compensation will be claimed by us on this account. Instructions of MCGM in this respect shall be complied with in the prescribed time frame.

I further undertake to indemnify MCGM that if any damage is caused to other underground services, we will make the good at our risk and cost and MCGM or its

servants will not be held responsible for such damage. I hereby indemnify that if any legal suits or complications arise out of this permission or any damages caused to entity; we shall be wholly be responsible for it and MCGM will not be responsible for it

Authorized signatory
M/s

MUNICIPAL CORPORATION OF GREATER MUMBAI

No. : MGCT/8659 Dtd/ 07.09.2019.

Sub : Arbitration clause in the Standard General Conditions of Contract for Construction Works, 2016.

In one of the cases of W.S.P. regarding arbitration dispute, a note was submitted by DyLaw Officer (High Court, Suit & PIL) and subsequently the report is submitted by Jt. M.C. (Vig.) vide No. Jt.M.C./Vig./69/MC dtd. 21-8-2019 proposing a process to deal with the arbitration matters as per the Law & Judiciary, Govt. of Maharashtra, policy for institutional arbitration vide it's G.R. dtd. 13-10-2016 and the report submitted by Jt. M.C. (Vig.) is approved by Hon'ble M.C. on 17-8-2019.

There is a provision of arbitration clause in the Standard General Condition of Contract for Construction Works, point no. 13 (e) reads as follows :-

13.e) Arbitration and Jurisdiction:

If the Commissioner shall fail to give notice of the decision as aforesaid within a period of 90 days after being requested as aforesaid, or if the Contractor be dissatisfied with any such decision, then and in any such case the Contractor may within 90 days after receiving notice of such decision or within 90 days after the expirations of the first named period of 90 days (as the case may be) require that the matter or matters in dispute be referred to arbitration as hereinafter provided. All disputes or differences in respect of which the decision (if any) of the Commissioner has not become final and binding as aforesaid shall be finally settled by arbitration as follows:

Arbitration shall be effected by a single arbitrator agreed upon the parties. The arbitration shall be conducted in accordance with the provisions of the Arbitration Act, 1996 or any statutory modifications thereof, and shall be held at such place and time within the limits of Brihan Mumbai as the arbitrator may determine. The decision of the arbitrator shall be final and binding upon the parties hereto and the expense of the arbitration shall be paid as may be determined by the arbitrator. Performance under the Contract shall, if reasonably be possible, continued during the arbitration proceedings and payment due to the Contractor by the Employer shall not be withheld unless they are the subject matter of arbitration proceedings. The said arbitrator shall have full power to open up, review and revise any decision, opinion, direction, certification or valuation of the Commissioner and neither party shall be limited in the proceedings before such arbitrator to the evidence or arguments put before the Commissioner for the purpose of obtaining his said decision.

No decision given by the Commissioner in accordance with the foregoing provisions shall disqualify him from being called as a witness and giving evidence before the arbitrator on any matters whatsoever relevant to the disputes or difference referred to the arbitrator as aforesaid.

All awards shall be in writing and for claims equivalent to 5,00,000 or more such awards shall state reasons for amounts awarded. The expenditure of arbitration shall be paid as may be determined by arbitrator.

In case of any claim, dispute or difference arising in respect of a contract, the cause of action thereof shall be deemed to have arisen in Mumbai and all legal proceedings in respect of any claim, dispute or difference shall be instituted in a competent court in the City of Mumbai only.

As per Hon'ble M.C.'s approval dtd. 17-8-2019, the existing clause is now replaced as follows :

13.e Arbitration and Jurisdiction

If the Commissioner fails to give notice of the decision as aforesaid within a period of 90 days after being requested as aforesaid or if the Contractor is dissatisfied with any such decision, then the Contractor may within 90 days after receiving notice of such decision or within 90 days after the expiration of the first named period of 90 days (as the case may be) require that the matter or matters in dispute be referred to arbitration as hereinafter provided.

i) In case of a contract where the contract price and/ or contract value is less than Rs. 5,00,00,000/- (Rupees Five Crore Only), any dispute arising out of or in connection with this contract, including any question regarding its existence, validity or termination, shall be referred to a mutually agreed arbitral tribunal in accordance with the Arbitration and Conciliation Act, 1996 (amended upto date). The arbitral tribunal shall consist of a sole arbitrator, as mutually agreed upon by the parties and the said dispute shall be finally resolved by the said arbitral tribunal. The decision of the arbitral tribunal shall be in writing (with reasons) and which will be final and binding upon the parties hereto and the expenses of the arbitration shall be paid as may be determined by the arbitral tribunal. The seat of the arbitration shall be Mumbai. The venue of arbitration shall be within the limits of Brihan Mumbai. The language of the Arbitration shall be English.

If the parties fails to appoint mutually agreed arbitral tribunal, within the period of 30 days from the date of application seeking arbitration in the dispute,

the arbitral tribunal shall be appointed by the recognised arbitral institution i.e. Mumbai Centre for International Arbitration (approved by Government of Maharashtra under G.R. no. ARB/Case No. 1/2017/D-19 dtd. 28.02.2017) as per the Arbitration Rules of the Mumbai Centre for International Arbitration then in force ("MCIA Rules").

(ii) In case of contract where the contact price and/ or contract value is Rs.5,00,00,000/- (Rupees Five Crore Only) or more, any dispute arising out of or in connection with such a contract, including any question regarding its existence, validity or termination, shall be directly referred to and finally resolved by the recognized arbitral institution i.e. Mumbai Centre for International Arbitration (approved by Government of Maharashtra under G.R. no. ARB/Case No. 1/2017/D-19 dtd. 28.02.2017) as per the Arbitration Rules of the Mumbai Centre for International Arbitration then in force ("MCIA Rules"). The arbitral tribunal shall consist of a sole arbitrator. The seat of the arbitration shall be Mumbai. The language of the Arbitration shall be English.

In either case, the law governing this arbitration agreement and the contract shall be Indian Law.

All the HoDs are hereby directed to note the revised clause in G.C.C. as mentioned above and ensure that the same is included in the tenders invited from 15-1-2019 onwards. If the tenders are already invited before 15-1-2019 and the Packet 'A' is not opened, then the corrigendum shall be issued so as to see that all the new tenders accepted/invited after 15-9-2019 shall include this revised condition and will become a part of the contract for all such works.

Sd/-22.08.2019
Dir. (E.S. & P.)
P

Sd/-29.08.2019
A.M.C. (P)

Sd/-06.09.2019
M.C.

No.. : DIR/ES&P/919/MC dtd. 16.09.2019.

Copy to :

Asstt. Comm. Ward / City Engineer/Ch.Eng.(Roads & Traffic) / Ch.Eng. (Bridges) / Ch.Eng. (WSP) / Ch.Eng. (S.P.) / Ch.Eng.(MSDP) / Ch.Eng. (BM) / Ch.Eng.(Vig) / Ch.Eng. (M&E) / Ch.Eng.(D.P.)/Ch.Eng.(SWD) / Ch.Eng.(SWM) / Ch.Eng.(CTIRC)/Ch.Eng. (Coastal Roads) / Dy. Ch.Eng.(HIC) / Dy.Ch.Eng.(SIC), Supdt. of Gardens / CA (F) / CA (WSSD) / CA (CPD)

Forwarded for information and necessary action please.

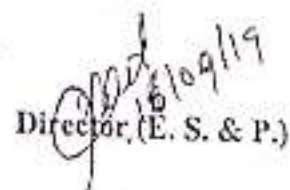
Director, (E. S. & P.)

MUNICIPAL CORPORATION OF GREATER MUMBAI

Ch. Eng / 369 / SR /Roads & Traffic of 28/10/2021

Assured Access of Machinery & Equipment

(Stage-I, II and III Tenders)

- Sub.:**
1. E-Tenders for work codes E-265, E-266, E-272, E-268, E-267, AE-133, E-271, E-277, E-278, E-279, E-269, W-361, AW-207, AW-218, W-362, W-370, W-374, AW-205, AW-204, AW-222, W-364, W-375, W-377, W-367, W-382, AC-171, AC-172, C-274, C-275 from the department of Chief Engineer (Roads & Tr.)
 2. E-Tenders for work codes C -287, C-292, C-282, C-288, C-289, C-281, C-285, C-283, C-286, C-276, C-280, AW-225, AW-197, AW-226, AW-227, W-381, AW-224 and E-282 from the department of Chief Engineer (Roads & Tr.)
 3. E-Tenders for work codes C-291, E-283, E-284, E-285, W-400, W-366, W-387 and W-379 from the department of Chief Engineer (Roads & Tr.)

Ref.: Clarification regarding submission of **Annexure-H**.

It is proposed to allow the bidders to submit the Undertaking for assured access of machinery & equipments on Rs. 500/- stamped papers instead of registered undertaking for the tenders invited through Roads Department.

Sr No	Relevant Clause	Prevailing tender Condition (as amended by Prebid Minutes of Meeting)	Proposed Modified Tender Condition.
1	2.5 A	<u>Annexure-H</u> The request is considered & condition No-2.5 (A) is revised as under: The bidder shall upload the registered	The bidder shall upload the undertaking on Rs.500 stamped paper for assured access of Machinery and Equipments as listed in

Sr No	Relevant Clause	Prevailing tender Condition (as amended by Prebid Minutes of Meeting)	Proposed Modified Tender Condition.
		undertaking on Rs.500 stamped paper for assured access of Machinery and Equipments as listed in the modified Annexure-H.	the modified Annexure-H.

In view of the above, Ch.E. (Roads & Traffic)'s approval is requested to:

1. the Corrigendum for Undertaking for Assured Access of machinery & equipments.
2. Publishing this corrigendum on portal and uploading in SRM System.

Submitted for approval please.

Shri Manoj Kamat
Dy.Ch.E. (Roads) W.S.

Shri Chandrakant Metkar
Dy.Ch.E.(Roads) E.S.

Shri Ashok Mestry
Dy.Ch.E.(Roads) City

Shri Rajendra Talkar
Ch.E. (Roads & Traffic) / DMC (Infra.)



दृश्य-१९-२००६-०७-१,००,०००

पृथकपत्र

MUNICIPAL CORPORATION OF GREATER MUMBAI

Ch. Eng / 369 / SR /Roads & Traffic of 28/10/2021

Corrigendum for Assured Access of Machinery & Equipment (Stage-I, II and III Tenders)

- Sub.:**
1. E-Tenders for work codes E-265, E-266, E-272, E-268, E-267, AE-133, E-271, E-277, E-278, E-279, E-269, W-361, AW-207, AW-218, W-362, W-370, W-374, AW-205, AW-204, AW-222, W-364, W-375, W-377, W-367, W-382, AC-171, AC-172, C-274, C-275 from the department of Chief Engineer (Roads & Tr.)
 2. E-Tenders for work codes C -287, C-292, C-282, C-288, C-289, C-281, C-285, C-283, C-286, C-276, C-280, AW-225, AW-197, AW-226, AW-227, W-381, AW-224 and E-282 from the department of Chief Engineer (Roads & Tr.)
 3. E-Tenders for work codes C-291, E-283, E-284, E-285, W-400, W-366, W-387 and W-379 from the department of Chief Engineer (Roads & Tr.)

Ref.: Clarification regarding submission of **Annexure-H**.

Sr No	Relevant Clause	Prevailing tender Condition (as amended by Prebid Minutes of Meeting)	Modified Tender Condition.
1	2.5 A	<p>Annexure-H The request is considered & condition No-2.5 (A) is revised as under: The bidder shall upload the registered undertaking on Rs.500 stamped paper for assured access of Machinery and Equipments as listed in the modified Annexure-H.</p>	<p>The bidder shall upload the undertaking on Rs.500 stamped paper for assured access of Machinery and Equipments as listed in the modified Annexure-H.</p>



Shri Rajendra Talkat

Ch.E. (Roads & Traffic) / DMC (Infra.)

२०१९-२०

क्रमांक : सीए/एचबीके/२४९, दिनांक २७.११.२०१९

विषय : बँकेने दिलेले हवीपत्र (बँकर्स गॅरंटी) स्थितीबाबत.

संदर्भ : सीए/एचबीके/३९, दिनांक - ०७/१२/२०१२

सीए/एचबीके/२५, दिनांक - १०/१०/२०१२

कंत्राटदार / पुरवठादार घाब्याकडून सादर करण्यात येणारी बँक हवीपत्रे (बँकर्स गॅरंटी) स्थितीबाबतसंदर्भात उपरोक्त संदर्भाधीन परिपत्रकांमधील मार्गदर्शनपर सूचना परिप्रेक्षित करण्यात आल्या आहेत. सादर परिपत्रकातील परिच्छेद क्रमांक २ मध्ये पुढील प्रमाणे सुधारणा करण्यात येत आहेत.

सादर परिपत्रकात नमूद वेबसाईट व भारतीय रिझर्व बँकेची "rbidocs.rbi.org.in/introductory/publications/pdf/B4656.pdf" ही लिंक "www.rbi.org.in" अशी वापरण्यात यावी.

हरी, सर्व खातेप्रमुख, सहाय्यक महापालिका आयुक्त आणि संबंधित घांनी वटील सुधारणेची नोंद घेऊन संबंधित कंत्राटदार/पुरवठादार यांना अवगत करावे.

तारी/- १४.११.२०१९

प्रमुख लेखापाल (अ.पु.म.वि.)

तारी/- १४.११.२०१९

प्रमुख लेखापाल (वित्त) प्र.

परिपत्रक

२०१९-२०

क्रमांक : सीए/एचबीके/२४९, दिनांक २७.११.२०१९

----- यांचा प्रत (-----) अधिक प्रतीसह
माहितीकरिता व योग्य त्या कार्यवाहीसाठी पाठविले आहे.

सादर परिपत्रक महानगरपालिकेच्या <http://hr.mca.gov.in/Circular/CA/Finance/2019/> या संकेतस्थळावर प्रसिद्ध करण्यात आलेले आहे.

वि.प्र. कडरे. ६४१०९८

प्रमुख लेखापाल (वित्त) यांच्यावरिल

बृहन्मुंबई महानगरपालिका

क्र.प्रले/पापुमनि/अर्थसंकल्प/एफ्आय/५७८ दिनांक : /१२/२०२०

विषय: बृहन्मुंबई महानगरपालिकेची आर्थिक स्थिती सुधारण्यासाठी काटकसरीच्या उपाययोजना – निकड व महत्त्व.

संदर्भ: १) अति.आ./प्र./४३८३ दि. ०९.१०.२०२०

२) प्रले/पापुमनि/अर्थसंकल्प/एफ्आय/३४० दि.१३.१०.२०२०

.....

बृहन्मुंबईमध्ये कोवीड-१९ या साधारणरोगाच्या (Epidemic) प्रादुर्भावाने उद्भवलेल्या परिस्थितीमुळे, विद्यमान आर्थिक वर्षामध्ये प्राप्त झालेल्या महसुली उत्पन्नापेक्षा महसुली खर्चात झालेली लक्षणीय वाढ लक्षात घेता बृहन्मुंबई महानगरपालिकेची आर्थिक स्थिती सुधारण्यासाठी, सन २०२०-२०२१ या आर्थिक वर्षाकरिता दैनंदिन महसुली खर्चासाठी उपलब्ध करून देण्यात आलेल्या तरतुदीतून किमान २०% बचत करण्याबाबतचे निर्देश दि.०३.०९.२०२० रोजीच्या परिपत्रक क्र.प्रले/एफडीटी/२२ अन्वये देण्यात आले आहेत. सन २०२०-२१ चे सुधारित अंदाज व सन २०२१-२०२२ चे अर्थसंकल्पीय अंदाज सादर करण्यासाठी दि.०१.१०.२०२० रोजी क्र.प्रले/पापुमनि/अर्थसंकल्प/०२ अन्वये प्रसूत करण्यात आलेल्या परिपत्रकान्वये महसुली खर्चाबाबत खालील प्रमाणे सूचना देण्यात आल्या आहेत.

महसुली खर्चाच्या बाबतीत आस्थापना, निवृत्तवेतन आदी खर्च तसेच प्रत्येक मतदार संघामध्ये अनपेक्षित कामांसाठी ठोक तरतूद म्हणजेच नगरसेवक निधी आणि विद्युत आकार, मालमत्ता कराचे व जल आकाराचे अधिदान या सेवाशिर्षाखालील खर्च वगळता अन्य दैनंदिन महसुली खर्चासाठी सन २०२०-२०२१ या आर्थिक वर्षाकरिता उपलब्ध करून देण्यात आलेल्या तरतुदीतून किमान २०% बचत करणे आवश्यक आहे. तसेच बरेचदा असे निदर्शनास आले आहे की, केवळ अर्थसंकल्पीय तरतूद उपलब्ध आहे म्हणून अनावश्यक स्वरूपाची कामे हाती घेण्यात येतात, अशा स्वरूपाची अनावश्यक कामे हाती घेण्यात येऊ नयेत. त्यादृष्टीने सद्यस्थितीत आर्थिक काटकसर करून खर्च कमी करण्यासाठी परिपत्रक क्र.सीए/एफडीटी/२२ दि.०३.०९.२० अन्वये मार्गदर्शक सूचना पारित केल्या आहे.

तसेच मा.अतिरिक्त आयुक्त (प्रकल्प) यांनी संदर्भ क्र.१ अन्वये व्यक्तीशः पाठविलेल्या अर्धशासकीय पत्रान्वये जल अभियंता यांना महसुली खर्चात किमान २०% बचत करण्याबाबतचे निर्देश दिले आहेत. तथापि, जल अभियंता खात्याकडून प्राप्त झालेल्या महसुली खर्चाच्या सन २०२०-२०२१ च्या सुधारित अंदाजाची व सन २०२१-२०२२ च्या अर्थसंकल्पीय अंदाजाची पडताळणी केली असता सदर निर्देशाचे पालन झाल्याचे दिसून न आल्याने या कार्यालयाने संदर्भ क्र.२ अन्वये सन २०२०-२०२१ च्या सुधारित अंदाजात व सन २०२१-२०२२ च्या अर्थसंकल्पीय अंदाजात सुयोग्य बदल करण्याबाबत कळविले होते.

परंतू तदनंतरही खात्यांकडून प्राप्त प्रस्तावावर प्रमुख लेखापाल (पापुमनि) यांच्या स्तरावर आयोजित अर्थसंकल्पीय बैठकींदरम्यान वाढीव तरतुदीची मागणी करण्यात येत आहे. सद्यपरिस्थितीमुळे विद्यमान आर्थिक वर्षात महानगरपालिकेच्या उत्पन्नामध्ये झालेली घट आणि वाढत असलेला खर्च लक्षात घेता महानगरपालिकेची सध्याची आर्थिक स्थिती ही कोणतेही अतिरिक्त दायित्व स्वीकारण्याइतकी भक्कम नसल्यामुळे महसुली खर्चावर काही कडक

निर्बंध घालणे अत्यंत गरजेचे आहे. या अनुषंगाने ज्या कामांचे यापुर्वीच कायदेश देण्यात आले आहेत अशा कामांसाठी व अत्यंत आवश्यक/तातडीच्या कामासाठीच सन २०२०-२०२१ च्या महसुली खर्चाच्या सुधारित अंदाजात व सन २०२१-२०२२ च्या अर्थसंकल्पीय अंदाजात तरतूद प्रस्तावित करण्यात यावी. अशाप्रकारे सन २०२०-२०२१ च्या सुधारित अंदाजात व सन २०२१-२०२२ च्या अर्थसंकल्पीय अंदाजात प्रस्तावित करण्यात आलेल्या कामांची माहिती (List of Identified Works) सोबत जोडलेल्या प्रपत्रांमध्ये भरून दि.१५.१२.२०२० पर्यंत या कार्यालयास सादर करण्यास तसेच पुढील आठवड्यात मा. अतिरिक्त आयुक्त (प्रकल्प) यांच्या स्तरावर आयोजित केलेल्या बैठकीला सादर माहितीच्या एका प्रतीसह उपस्थित रहाण्यास संबंधितांना अवगत करण्यात यावे.

भांडवली खर्चाच्या बाबतीत सध्या जी भांडवली कामे हाती घेण्यात आलेली आहेत ती पूर्ण करावीत व त्यानंतर जी अत्यावश्यक व टाळता न येणारी आवश्यक असलेली कामेच हाती घेण्यात यावीत, तथापि अशा प्रत्येक कामाला संबंधित मान. अतिरिक्त आयुक्त यांची विशिष्ट मंजूरी घ्यावी. तसेच जल अभियंता खात्यांतर्गत विद्यमान लेखा संकेतांकातूनच बऱ्याचदा नविन कामे प्रस्ताविल्याचे दिसून येते. अशा प्रत्येक नविन कामांसाठीसुद्धा मान. अतिरिक्त आयुक्त यांची मंजूरी प्राप्त करणे आवश्यक आहे.

कृपया सादरचे कामकाज अत्यंत तातडीचे समजावे.

जल अभियंता

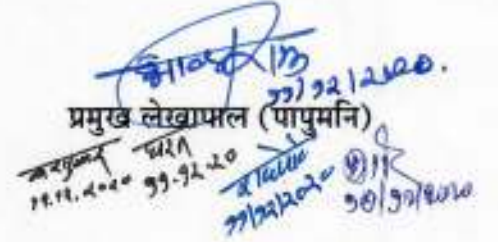
प्रमुख लेखापाल (पापुमनि)
२२/१२/२०२०
२०/१२/२०२०

Statement of Works to be carried out from Revenue Expenditure Grant of RE 2020-2021 and BE 2021-2022

Function Code : _____

Cost Centre : _____

GL Code : _____

Function Name : _____

Cost Centre Name : _____

GL Code Description : _____

(Rs. In Thousand)

Sr. No.	Description of Works	Administrative/ Executive Sanction No. & Date	Estimate Cost of Work	BE 2020-2021	Actuals as on 30.11.2020	RE 2020-2021	BE 2021-2022	Remarks
1	2	3	4	5	6	7	8	9
Total								

Note : Please prepare separate sheet for each GL Code.

बृहन्मुंबई महानगरपालिका
परिपत्रक
2019-20
क्र. सीए/एफआरजी/ 30 दिनांक 19.03.2020

विषय : महानगरपालिकेच्या विविध खात्यांमार्फत मागविण्यात येणा-या दरपत्रिका/ ई-दरपत्रिका/
ई-निविदा दस्तऐवजांच्या किमतीच्या दरात वाढ करण्याबाबत .

संदर्भ : 1) प्रले/एफसीई/28 दि. 13.01.2016 (पृ.क्र. प-1-2)

2) सीए/एफआरजी/07 दि. 03.07.2019 (पृ.क्र. प-29)

बृहन्मुंबई महानगरपालिकेच्या विविध खात्यांमार्फत मागविण्यात येणा-या दरपत्रिका/ ई-दरपत्रिका/
ई-निविदा दस्तऐवज यांची पक्षकारांकडून आकारण्यात येणारी किंमत उपरोक्त संदर्भ क्र. 02 वरील
परिपत्रकानुसार दिनांक 15.07.2019 पासून दिनांक 31.03.2020 पर्यंत सुधारित दराने आकारण्याबाबत निर्देश
देण्यात आले होते.

दिनांक 15.07.2019 पासून लागू करण्यात आलेल्या दरपत्रिका/ ई-दरपत्रिका/ई-निविदा दस्तऐवजांच्या
किमतीच्या दरामध्ये सन 2020-21 या वर्षामध्ये 10% वाढ करण्यात येत आहे. त्यानुसार लागू करावयाचे
सुधारित दर खालीलप्रमाणे आहेत :-

स्वारस्याची अभिव्यक्ती प्रस्ताव/मालाचा पुरवठा/सल्लागार सेवासह स्थापत्य कामे आणि सेवा इत्यादी विषयक कार्यालयीन अंदाजे रक्कम	अनस्टार दरपत्रिका/ निविदा/ दरपत्रिका/ ई-दरपत्रिका/ई-निविदा दस्तऐवजांची सुधारित किंमत दिनांक 01.04.2020 पासून
रु. 3 लाखापर्यंत	रु. 182/- अधिक वस्तु व सेवाकर
रु. 300001/- पेक्षा अधिक	कार्यालयीन अंदाजाच्या 0.09% (अशी येणारी रक्कम पुढील शंभराच्या पटीत परिवर्तित करणे यासापेक्ष) अधिक वस्तु व सेवाकर (म्हणजेच कमीत कमी रु. 300/- अधिक वस्तु व सेवाकर आणि जास्तीत जास्त रु. 8500/- अधिक वस्तु व सेवाकर)

अनस्टार दरपत्रिका/ निविदा/ दरपत्रिका/ ई-दरपत्रिका/ई-निविदा दस्तऐवजांच्या किमतीचे सुधारित दर
दिनांक 01.04.2020 पासून दिनांक 31.03.2021 पर्यंत अमलात येतील.

बृहन्मुंबई महानगरपालिका

परिपत्रक

२०१२-२०१३

परिपत्रक क्र.प्र.ले./एफआरटी/१२ दिनांक २१.०६.२०१२

विषय:- इमारत व इतर बांधकाम कामगार (रोजगार नियमन व सेवाशर्ती) अधिनियम १९९६ तसेच इमारत व इतर बांधकाम कामगार कल्याण उपकर नियम १९९८ अंतर्गत उपकर वसूल करावयाची कार्यपध्दती निश्चित करणेबाबत.

- संदर्भ:- १) इमारत व इतर बांधकाम कामगार (रोजगार नियमन व सेवाशर्ती) अधिनियम १९९६
२) इमारत व इतर बांधकाम कामगार उपकर अधिनियम १९९६
३) इमारत व इतर बांधकाम कामगार उपकर नियम १९९८
४) महाराष्ट्र इमारत व इतर बांधकाम कामगार (रोजगार व सेवाशर्ती नियमन) नियम २००७ दि.०५.०२.२००७.
५) महाराष्ट्र इमारत व इतर बांधकाम कामगार कल्याण उपकर नियम २००७.
६) शासन निर्णय क्र.बीसीए/२००९/प्र.क्र.१०८/कामगार ७-अ मंत्रालय मुंबई-३२ दि.१७.०६.२०१०.

इमारत व इतर बांधकाम कामगार (रोजगार विनियमन व सेवाशर्ती) अधिनियम १९९६ (केंद्रीय अधिनियम २७/१९९६) आणि त्या अंतर्गत इमारत व इतर बांधकाम कामगार कल्याण उपकर अधिनियम १९९६ हे कायदे केंद्र शासनाने, इमारत व इतर बांधकाम क्षेत्रात कार्यरत असलेल्या बांधकाम मजुरांचे कल्याण करण्याच्या उद्देशाने पारीत केले असून, सदर कायद्याची महाराष्ट्र राज्यात अंमलबजावणी करण्याच्या दृष्टीने, महाराष्ट्र शासन निर्णय क्र. बीसीए२००९/प्र.क्र.१०८/कामगार ७-अ दि.१७ जून २०१० अन्वये, इमारत व इतर बांधकाम कामगार (रोजगार विनियमन व सेवाशर्ती) अधिनियम १९९६ तसेच इमारत व इतर बांधकाम कामगार कल्याण उपकर नियम १९९८ अंतर्गत उपकर वसूल करावयाची कार्यपध्दती विहित केली आहे. त्यानुसार दि.०१.०१.२००८ च्या पूर्वलक्षी प्रभावापासून विहित केलेल्या दराने उपकर वसूल करून ३० दिवसांच्या आत शासकीय तिजोरीमध्ये भरणा करावयाचा आहे.

या संदर्भात, उप प्रमुख अभियंता (इमारत प्रस्ताव) शहर यांनी परिपत्रक क्र.उपप्रमुख अभियंता/३६६३/इ.प्र.(शहर) दि.३०.०९.२०११ अन्वये धोरण निश्चित केले आहे. मात्र त्यामधील खालील नमूद करावयाच्या राहून गेलेल्या मुद्दांबाबत सुधारित आदेश देण्यात येत आहेत.

अ.क्र.	परिपत्रक क्र. उपप्रमुख अभियंता/३६६३/इ.प्र.(शहर) दि.३०.०९.२०११ मधील नमूद मुद्दा	सुधारीत आदेश
१.	इमारत व इतर बांधकाम (रोजगार नियमन व सेवाशर्ती) अधिनियम १९९६ तसेच इमारत व इतर बांधकाम कामगार कल्याण उपकर नियम १९९८ अंतर्गत उपकराची वसुली दि.०१.०७.२०१० पासून करणे आवश्यक आहे.	इमारत व इतर बांधकाम (रोजगार नियमन व सेवाशर्ती) अधिनियम १९९६ तसेच इमारत व इतर बांधकाम कामगार कल्याण उपकर नियम १९९८ अंतर्गत उपकराची वसुली दि.०१.०१.२००८ च्या पूर्वलक्षी प्रभावाने करण्यात यावी.
२.	उपकराच्या रकमेचा भरणा करणे, ताळेबंद करणे व तो गोळा करण्याकरिता झालेल्या खर्चाचा परतावा इ. बाबतीची कार्यवाही प्रमुख लेखापाल खात्याने करणे अपेक्षित आहे.	शासन निर्णयासोबत जोडलेल्या प्रपत्र-१, परिशिष्ट-२, ३ व ४ अन्वये मंडळाला सादर करावायाचा तपशील संबंधित खात्यांशी निगडीत असल्याकारणाने उपकराच्या रकमेचा भरणा / ताळेबंद व तो वसूल करण्यासाठी झालेल्या खर्चाचा परतावा इ. बाबतीची कार्यवाही संबंधित खात्यानेच करावी व त्याचे लेखापरीक्षण व त्याबाबतच्या संप कार्यप्रणालीमध्ये नोंद घेण्याबाबतची कार्यवाही प्रमुख लेखापाल खात्यातर्फे करण्यात यावी. (याबाबतच्या अधिक स्पष्ट सूचना सदर परिपत्रकामध्ये पुढे देण्यात आल्या आहेत.)
३.	सदर अधिनियमांतर्गत - संबंधित विभाग शासकीय / निमशासकीय उपक्रम यांनी बांधकामास परवानगी देण्याच्या प्रत्येक प्रकरणास युनिक क्रमांक देऊन, बांधकाम सुरु करण्याच्या प्रमाणपत्रामध्ये तो नमूद करणे आवश्यक असल्याचा तरतुदीचा उल्लेख सदर परिपत्रकामध्ये केलेला नाही.	सर्व संबंधित विभाग शासकीय / निमशासकीय उपक्रम यांनी बांधकामास परवानगी देण्याच्या प्रत्येक प्रकरणास युनिक क्रमांक द्यावा आणि हा क्रमांक बांधकाम सुरु करण्याच्या प्रमाणपत्रामध्ये नमूद करावा. महाराष्ट्र व इतर बांधकाम उपकरासंबंधीचा हा युनिक कोड नसेल तर बांधकाम सुरु करण्याचे प्रमाणपत्र अपूर्ण असल्याचे मानण्यात यावे.

उप प्रमुख अभियंता (इमारत प्रस्ताव) शहर यांनी उपरोक्त परिपत्रकान्वये केवळ इमारत प्रस्ताव विभागापुरतेच धोरण निश्चित केले आहे. तथापि, कंत्राटदाराच्या बाबतीत त्यांच्या देयकांमधून उपकराची रक्कम वसूल करावयाची असून, स्थानिक प्राधिकरणामार्फत करण्यात येणाऱ्या इमारत व इतर बांधकामावरही उपकराची आकारणी करावयाची असल्याने शासन परिपत्रक क्र.बीसीए२००७/प्र.क्र.७८८/कामगार ७-अ दि.२६.१०.२००९ व शासन निर्णय क्र.बीसीए/२००९/प्र.क्र.१०८/कामगार ७-अ दि.१७.०६.२०१०

च्या प्रती सोबत जोडल्या असून त्यामधील मार्गदर्शक तत्त्वांनुसार विहित केलेल्या कार्यपध्दतीने उपकराची वसुली व शासकीय तिजोरीमध्ये भरणा करण्यात यावा.

याशिवाय वरील कार्यपध्दतीमध्ये सुसूत्रता राखण्याच्या दृष्टीने तसेच लेखा परीक्षण व संप कार्यप्रणालीच्या अनुषंगाने खालील मार्गदर्शक तत्त्वे / सूचना विहित करण्यात आल्या आहेत.

- १) इमारत व इतर बांधकामावर आकारण्यात येणाऱ्या उपकराची रक्कम ३५०३०९९०५ (इमारत बांधकाम कल्याणकारी उपकर) या लेखा संकेतांकाखाली जमा करण्यात यावी.
- २) जमा करण्यात आलेली उपकराची रक्कम-शासकीय तिजोरीत भरणा करण्यापूर्वी संबंधित खात्याने, संबंधित लेखा विभागाकडून त्याची पडताळणी करून घेतल्यावरच उपकराच्या रकमेचा धनादेश विहित केलेल्या कालावधीमध्ये संबंधित खात्यानेच (विभागीय कार्यालयामध्ये ज्यांनी कंत्राटदाराला कार्यादेश दिला असेल त्या संबंधित खात्याने) शासकीय तिजोरीमध्ये जमा करावा. मात्र कोणत्याही परिस्थितीमध्ये विहित केलेल्या कालावधीचे उल्लंघन-होणार नाही याबाबीची खबरदारी संबंधित खात्याने घ्यावी.
- ३) "इमारत व इतर बांधकाम उपकराद्वारे" जमा केलेली रक्कम मंडळाकडे ३० दिवसांच्या आत जमा करणे आवश्यक असल्याने कार्यालयीन सोयीसाठी प्रत्येक महिन्याच्या पहिल्या पंधरवड्यात जमा होणारा उपकर त्याच महिन्याच्या ३० तारखेपर्यंत तर दुसऱ्या पंधरवड्यात जमा होणारा उपकर पुढील महिन्याच्या १४ तारखेपर्यंत संबंधित खात्यांनी मंडळाकडे भरावा.
- ४) उपकराच्या रकमेचा धनाकर्ष महाराष्ट्र राज्य इमारत व इतर बांधकाम कामगार कल्याणकारी मंडळ मुंबई यांच्या खाते क्र. ००४२२०११००००१५३ 'बँक ऑफ इंडिया' मुंबई यांच्या कोणत्याही शाखेत विहित चलनाद्वारे जमा करावा. चलनाची प्रत शासन निर्णयासोबत जोडली असून चलनाच्या प्रती बँकेत किंवा मंडळाच्या वांद्रे कुर्ला कॉम्प्लेक्स येथील कार्यालयात उपलब्ध असतील.
- ५) भरणा केलेल्या उपकराच्या रकमेबाबतचा त्रैमासिक अहवाल अर्थसंकल्प अ, ब व ई च्या बाबतीत संबंधित खात्याने लेखा अधिकारी (महसूल) विक्रीकर विभाग व अर्थसंकल्प 'ग' बाबतीत लेखा अधिकारी (रोख) पा.पु.म.नि. यांजकडे दिनांक १५ एप्रिल, १५ जुलै, १५ ऑक्टोबर, १५ जानेवारी पूर्वी नियमितपणे पाठवावा.
- ६) उपकराची वसुली व भरणा इ. संदर्भातील आवश्यक तो सर्व तपशील संबंधित खात्याने शासन निर्णयामध्ये विहित केलेल्या कालावधीमध्ये त्यासोबत जोडलेल्या विहित प्रपत्र / परिशिष्टांन्वये अध्यक्ष, महाराष्ट्र इमारत व इतर बांधकाम कामगार कल्याण मंडळ, वांद्रे कुर्ला कॉम्प्लेक्स, कामगार आयुक्तांचे कार्यालय, कामगार भवन, आर.बी.आय.च्या बाजूला, वांद्रे (पूर्व), मुंबई - ४०० ०५१ यांना सादर करावा.

मंडळाला विविध परिशिष्टे सादर करावयाच्या कालावधीचा तपशील खालीलप्रमाणे आहे.

१	प्रपत्र - १	प्रत्येक मालक बांधकामाचे काम सुरु झाल्यापासून ३० दिवसांत किंवा उपकराची रक्कम भरल्यानंतर मंडळाला सादर करेल.
२.	परिशिष्ट-२	संबंधित खात्याने उपकरापोटी जमा करण्यात आलेल्या रकमेचा तपशील दर्शविणारा मासिक तक्ता पुढील महिन्याच्या १० तारखेपूर्वी मंडळाला सादर करावा.
३.	परिशिष्ट-३	संबंधित खात्याने मंडळाला १५ मे पूर्वी सादर करावयाचे वार्षिक विवरणपत्र.
४.	परिशिष्ट-४	आराखडे मंजूर करणाऱ्या प्राधिकार्याने १५ मे पूर्वी सादर करावयाचे वार्षिक विवरणपत्र.

७) उपकराची वसुली व शासकीय तिजोरीमध्ये भरणा केल्याबाबतचा सर्व अभिलेख संबंधित खात्यांनी, जतन करावा.

८) सोबत जोडलेल्या शासन निर्णयामधील परिशिष्ट एक मधील मार्गदर्शक तत्त्व क्र. १२ अन्वये युनिक कोड नंबर संबंधीच्या सूचना केलेल्या आहेत त्या संदर्भात अधिक स्पष्टीकरणासाठी शासन परिपत्रक क्र. बीसीए २००७/प्र.क्र.७८८/कामगार ७-अ दि.२६ ऑक्टोबर २००९ ची प्रतदेखील सोबत जोडण्यात आली आहे.

९) ज्या प्रकरणी कंत्राटदारांच्या देयकामधून तसेच खात्यामार्फत करण्यात येणाऱ्या बांधकामाच्या खर्चाच्या १% एवढी उपकराची वसुली करावयाची असेल अशा प्रकरणी सदर रकमेतील शासनाला अधिदानीत करावयाची ९९% रक्कम ३५०३०९९०५ (इमारत व इतर बांधकाम कामगार कल्याण उपकर) या लेखा संकेतांकाखाली जमा करण्यात येऊन त्याबाबतचा धनाकर्ष बँकेत जमा करावा व सदर उपकराच्या वसुली खर्चापोटी कापून घेतलेली उर्वरित १% एवढी रक्कम १४०७००१०७ (इमारत व इतर बांधकाम कामगार कल्याण उपकराच्या वसुलीपोटी प्रशासकीय आकार) या लेखा संकेतांकाखाली जमा करण्यात यावी.

तसेच ज्या प्रकरणी बांधकामाच्या आराखडयास संबंधित प्राधिकरणाच्या मंजूरीची आवश्यकता आहे त्या प्रकरणी उपकरापोटी जमा केलेली १% एवढी सर्व रक्कम धनादेशाद्वारे बँकेत जमा करण्यात यावी व त्याच्या वसुलीपोटी येणाऱ्या खर्चाची रक्कम शासनाकडून विहित कालावधीमध्ये (१५ मे पूर्वी) दावा सादर करून प्राप्त करण्यात यावी.

१०) अर्थसंकल्प अ, ब व ई च्या बाबतीत प्रमुख लेखापाल (वित्त) खात्यातील संबंधित लेखा विभागाने तसेच अर्थसंकल्प 'ग' च्या बाबतीत प्रमुख लेखापाल (पा.पु.म.नि.) यांच्या अखत्यारितील संबंधित लेखा विभाग यांनी उपकराचा भरणा करावयाच्या रकमेचे लेखापरीक्षण करावे.

११) ज्या प्रकरणी, उपकराच्या वसुली खर्चापोटीची रक्कम शासनाकडून प्राप्त करावयाची आहे, त्या प्रकरणी शासनाला दावा दाखल केल्याच्या दिनांकाला सदर रक्कम शासनाकडून येणे रक्कम (रिसीव्हिबल) म्हणून

४३१५००३०६ (इमारत व इतर बांधकाम कामगार कल्याण उपकर वसुलीपोटी येणे असलेले प्रशासकीय आकार) या लेखा संकेतांकामध्ये संबंधित लेखा विभागाने पदस्थापित (अपलोड) करावी. तसेच शासनाकडे सादर केलेल्या दाव्याच्या रकमेपैकी प्राप्त झालेल्या रकमेची देखील योग्य ती समायोजना / लेखा नोंद, संबंधित लेखा विभागाने सॅप कार्यप्रणालीमध्ये घेऊन संबंधित लेखा विभागाने दावा सादर केलेल्या रकमेचा तसेच प्राप्त झालेल्या रकमेचा विहित नमुन्यामधील अहवाल लेखा अधिकारी (महसूल) एफआरव्ही उपविभागाकडे पाठवावा (विहित नमुन्याची प्रत सोबत जोडली आहे).

१२) सादर उपकराची वसुली दि.०१.०१.२००८ पासूनच्या पूर्वलक्षी प्रभावाने करावयाची असल्याने, आतापर्यंत जमा केलेल्या उपकराच्या रकमेचा भरणा वरील सूचनांनुसार संबंधित खात्याने कार्यवाही करून त्वरित शासकीय तिजोरीमध्ये करण्यात यावा.

१३) उपरोक्त सूचना या मार्गदर्शक स्वरूपाच्या असून याबाबत अधिक खुलाशाची आवश्यकता भासल्यास संदर्भित परिपत्रके / नियम / अधिनियम संदर्भित करण्यात यावेत अथवा लेखा अधिकारी (महसूल) / प्रमुख लेखापाल खाते यांच्या विभागाशी संपर्क साधण्यात यावा.

सर्व खाते प्रमुख, सहाय्यक आयुक्त, अधिष्ठाता रुग्णालय, नाटयगृह प्रमुख व इतर आस्थापना प्रमुखांनी त्यांच्या अधिकार क्षेत्रात काम करणाऱ्या संबंधित कर्मचाऱ्यांना उपरोक्त कार्यपध्दती व नियमांचे काटेकोरपणे अंमलबजावणी व पालन करण्याचे आदेश द्यावेत.

सही/- २६.०५.२०१२
प्रमुख लेखापाल (पा.पु.म.नि.)

सही/- २६.०५.२०१२
प्रमुख लेखापाल (कोषागार)

सही/- २३.०५.२०१२
प्रमुख लेखापाल (वित्त)

सही/- ०४.०६.२०१२
अतिरिक्त आयुक्त (प्रकल्प)

सही/- १९.०६.२०१२
महानगरपालिका आयुक्त

परिपत्रक

२०१२-२०१३

परिपत्रक क्र.प्र.ले./एफआरटी/१२ दिनांक २१.०६.२०१२

..... यांना प्रती (

जादा प्रतीसह) माहितीसाठी व

आवश्यक कार्यवाहीसाठी रवाना.

Rhandorkar
22/6/12
प्रमुख लेखापाल (वित्त) याजकरिता

बृहन्मुंबई महानगरपालिका

परिपत्रक
२०२०-२१

क्र. प्रले/वित्त/प्रकल्प/४९ दिनांक : ०६.०२.२०२१

विषय: बृहन्मुंबई महानगरपालिकेची कामे करणाऱ्या कंत्राटदारांकडून कोविड-१९ च्या अनुषंगाने Performance Guarantee न घेण्याबाबत.

संदर्भ: १. महाराष्ट्र शासन परिपत्रक क्र. संकीर्ण १०२०/प्र.क्र/१००/२०२०-व्यय-१२ दिनांक २९ जूलै, २०२०.

२. परिपत्रक क्र. उपप्रले/व्यय/ /०६ दिनांक १०.०६.२०२०

३. परिपत्रक क्र. प्रले(वित्त)/प्रकल्प/ २० दिनांक २०.०६.२०२०

४. परिपत्रक क्र. प्रले(वित्त)/प्रकल्प/ २१ दिनांक ०७.०९.२०२०

५. परिपत्रक क्र. प्रले(वित्त)/प्रकल्प/ ३६ दिनांक ०७.१२.२०२०

कोरोना साथीच्या प्रादुर्भावामुळे महानगरपालिकेचे काम करणाऱ्या कंत्राटदारांना चालू कंत्राटामध्ये सोसाव्या लागत असलेल्या विविध अडथळांबाबत उपाययोजना व सहाय्य करण्याबाबत केंद्र सरकार व राज्य सरकारच्या धर्तीवर उपरोक्त परिपत्रके निर्गमित करून विविध उपाययोजना व सहाय्य देण्यात आलेले आहे.

उपरोक्त संदर्भ क्र.३ परिपत्रकान्वये दि.२५.०३.२०२० पूर्वी चालू झालेल्या/मंजूर झालेल्या/निविदा प्राप्त झालेल्या /निविदा मागविलेल्या सर्व कामांसाठी प्राप्त केलेले/करावयाचे कार्यानुसंग हमीपत्र (Performance Guarantee) संबंधीत कंत्राटदारास परत करण्यात यावे किंवा नव्याने घेण्यात येऊ नये असे निदेश दिले आहेत. त्याचप्रमाणे संदर्भ क्र.५ दि.०७.१२.२०२० रोजीच्या परिपत्रकान्वये नव्याने मागविण्यात येणाऱ्या निविदांमध्ये कार्यानुसंग हमीपत्र (Performance Guarantee) कंत्राटदाराकडून घेण्यात येऊ नये असे निदेश दिले आहेत.

तथापी, दिनांक २५.०३.२०२० ते ०७.१२.२० हया कालावधीत म्हणजेच कोरोना साथीचा जोर असलेल्या कालावधीत महापालिकेतील कामे करण्यासाठी पुढे आलेल्या कंत्राटदारांना उक्त कोणतीही सवलत दिली गेलेली नाही. अशा कंत्राटदारांकडूनही उक्त सवलतीसाठी मागणी होत आहे. कोरोना साथीच्या अनुषंगाने केंद्र शासनाने लागू केलेल्या टाळेबंदी पश्चातच्या खडतर कालावधीतही महापालिकेची कामे करण्यासाठी पुढे आल्याची बाब विचारात घेता, खालील प्रमाणे सवलत देण्यात येत आहे.

दिनांक २५.०३.२०२० ते ०७.१२.२० हया कालावधीत चालू झालेल्या/मंजूर झालेल्या/निविदा प्राप्त झालेल्या/निविदा मागविलेल्या सर्व कामांसाठी प्राप्त केलेले/करावयाचे कार्यानुसंग हमीपत्र (Performance Guarantee) संबंधीत कंत्राटदारास परत करण्यात यावे किंवा नव्याने घेण्यात येऊ नये. परंतु, सदर अशा कामासाठी स्विकृतीपत्र (Letter of Acceptance) प्राप्त झाल्याच्या दिनांकापासून ३० दिवसात २ टक्के कंत्राट अनामत रक्कम म्हणून सदर कामाचा दोष दायित्व कालावधी पूर्ण होईपर्यंत वैध असलेले बँक हमीपत्र प्राप्त केलेले असणे/करणे आवश्यक असेल. तसेच निविदा अटीनुसार काम पूर्ण

झाल्यानंतर ५० टक्के रिटेंशन मनीचे अधिदान केल्यानंतर उर्वरित ५० टक्के रिटेंशन मनी परत करताना सदर कामाचा दोष दायित्व कालावधी पूर्ण होईपर्यंत हमी म्हणून संबंधित कंत्राटदाराकडून दोष दायित्व कालावधी संपेपर्यंत वैध असणारे बँक हमीपत्र घेणे आवश्यक असेल.

सर्व संबंधित अधिष्ठाता/सहाय्यक आयुक्त/खातेप्रमुख यांनी उपरोक्त निर्देशांची अंमलबजावणी काटेकोरपणे करावी.

03/02/2021
प्रमुख लेखापाल (वित्त)

अतिरिक्त आयुक्त (प्रकल्प)

महानगरपालिका आयुक्त

१/२/२१

३/१०/२०२१

बृहन्मुंबई महानगरपालिका

परिपत्रक

२०२०-२१

क्र.प्रले(वित्त)/४२

दिनांक ०९.०१.२०२१

विषय:- बृहन्मुंबई महानगरपालिकेत कंत्राटदारामार्फत पार पाडावयाच्या कामाच्या मसुदा निविदेमध्ये अतिरिक्त सुरक्षा अनामत रक्कमेबाबतची सुधारित अट समाविष्ट करण्याबाबत.

संदर्भ:- एमडीडी/७८७८ दिनांक २७.०९.२०१६.

बृहन्मुंबई महानगरपालिकेत कंत्राटदारामार्फत पार पाडण्यात येणाऱ्या कामाकरिताच्या मसुदा-निविदेत समाविष्ट करावयाच्या अतिरिक्त सुरक्षा अनामत रक्कमेबाबतच्या अटीबाबतचे निर्देश संदर्भित परिपत्रकान्वये निर्गमित करण्यात आले आहेत. त्यामध्ये खालीलप्रमाणे सुधारणा करण्यात येत आहे.

विद्यमान पध्दत:-

ई-निविदा सूचनेस प्रतिसाद करून ज्या ज्या कंत्राटदारांनी वजा -१२% पेक्षा कमी दराने टक्केवारी उद्धृत केली आहे, अश्या सर्व कंत्राटदारांना वजा १२% पेक्षा जास्त नमूद केलेल्या प्रत्येक टक्क्याला १% याप्रमाणे कोणतीही मर्यादा न ठेवता ऑनलाईन निविदा सादर करताना अतिरिक्त सुरक्षा अनामत रक्कम ऑनलाईन स्विकारली जाते.

सुधारित पध्दत:-

१. कंत्राटदाराने वजा -१२% पेक्षा कमी दराने टक्केवारी उद्धृत केली असल्यास वजा १२% पेक्षा जास्त असलेल्या प्रत्येक टक्क्याला १% याप्रमाणे ऑनलाईन निविदा सादर करताना अतिरिक्त सुरक्षा अनामत रक्कमेचा ऑनलाईन भरणा करणे आवश्यक नसेल.

२. कंत्राट रकमेनुसार सक्षम प्राधिकाऱ्यांची मंजूरी प्राप्त झाल्यानंतर प्रथम लघुत्तम असलेल्या निविदाकाराने कार्यस्विकृती पत्रात नमूद केल्यानुसार कार्यालयीन कामकाजाच्या १५ दिवसात विद्यमान पध्दतीनुसार अतिरिक्त सुरक्षा अनामत रक्कम डिमांड ड्राफ्ट स्वरूपात महानगरपालिकेचा नागरी सुविधा केंद्रात जमा करणे व त्या पावतीची प्रत खातेप्रमुखाकडे सादर करणे आवश्यक असेल.

३. जर प्रथम लघुत्तम निविदाकाराने कार्यस्विकृती पत्रात नमूद केल्यानुसार कार्यालयीन कामकाजाच्या १५ दिवसामध्ये अतिरिक्त सुरक्षा अनामत रक्कम जमा केली नाही तर सदर कंपनीने भरणा केलेली संपूर्ण इसारा अनामत रक्कम (EMD) जप्त केली जाईल तसेच कंपनीला दोन वर्षासाठी डीबार (Debar) करण्यात येईल, त्याचप्रमाणे त्या कंपनीचे संचालक/

LOA)

(After giving)

पार्टनर इतर कंपनीमध्ये संचालक/ पार्टनर म्हणून कार्यरत असतील तर ती कंपनी सुद्धा दोन वर्षाकरिता डीबार (Debar) करण्याची कार्यवाही करण्यात येईल.

यापुढील कामाकरिताच्या मसुदानिविदेत परिपत्रकात नमूद केल्याप्रमाणे अतिरिक्त सुरक्षा अनामत रक्कमेबाबतची अट अंतर्भूत करण्यात यावी.

उपरोक्त सूचनांचे काटेकोरपणे अंमलबजावणी करण्याबाबत सर्व खाते प्रमुख/ सहाय्यक आयुक्त/ रुग्णालय अधिष्ठाता/ वैद्यकीय अधिक्षक/ उप प्रमुख लेखापाल/ लेखा अधिकारी यांनी दक्षता घ्यावी.

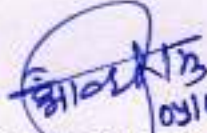

09/02/2021
(रा. क. आह्लाड)

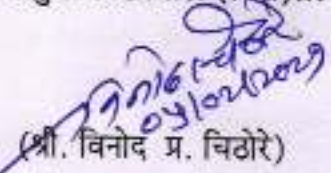
प्रमुख लेखापाल (वित्त)प्र.

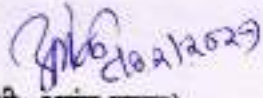
09/02/2021
(श्री. विनोद प्र. चिटोरे)
संचालक (अ.से.व.प्र)

09/02/2021
(श्री. अनंत कदम)

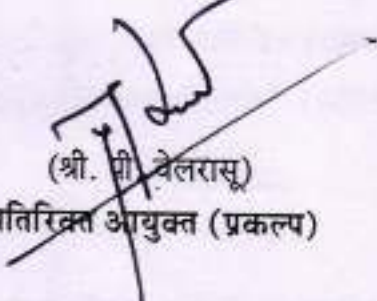
उपायुक्त - (पायाभूत सुविधा)

(श्री. पी. वेलरासू)
अतिरिक्त आयुक्त (प्रकल्प)

(श्री. इ.सिं. चहल)
महानगरपालिका आयुक्त 9/2/21

09/02/2021

BRIHANMUMBAI MAHANAGARPALIKA

CIRCULAR
2020-21

No.CA(F)/Project/ 32 of 26.10.2020

Sub : Bid Security or EMD

Ref : No.MDD/7878 of 27.09.2016

The MCGM's tender conditions have been amended and Standard Bid Document has been circulated vide No.MDD/7878 of 27.09.2016.

The condition of refund of Bid Security or EMD incorporated in SBD, is as follows :-

- (i) The Bid Security of the successful bidder will be discharged when the bidder has signed the agreement and furnished the required Security Deposits.
- (ii) The Bid Security/EMD of L-3 and bidders shall be refunded immediately after opening of financial bid but the EMD/ASD submitted by the L-2 bidder will be returned after obtaining Standing Committee Resolution.

In recent past, due to COVID-19 pandemic, various benefits and relief are given to contractor for ease of doing business and to maintain their cash flow. Further, the Statutory Committee meetings are not held in this pandemic situation. Hence, the condition of refund of Bid Security/EMD and ASD is reviewed and revised condition for all invited tenders wherein Statutory Committee's sanction has not been accorded and forthcoming e-tenders –

- (a) The Bid Security/EMD of the successful bidder will be discharged when the bidder has signed the agreement and furnished the required Security Deposits.
- (b) The Bid Security/EMD and ASD of L-2 and other higher bidders (L-3, L-4, etc.) shall be refunded immediately after opening of financial bid.

(c) In case, the successful bidder becomes non-responsive or successful bidder withdraws the bid or is unwilling to extend the bid validity period, in such circumstances, if L-2 bidder is agreeable to extend the bid validity period and ready to deposit the requisite amount of bid security/EMD and ASD to the department within the stipulated time period i.e. 15 days, the department will process further as per normal procedure.

The above revised directives shall come into effect immediately on issuance of this circular.

All Chief Engineers/Head of Departments/Deans shall note the above directives and follow them scrupulously.

Sd/-13.10.2020
C.A.(W.S.S.D.)

Sd/-13.10.2020
C.A.(Finance)i.c

Sd/-13.10.2020
D.M.C.(Infra)

Sd/-13.10.2020
D.M.C.(E)

Sd/-13.10.2020
Dir.(ES&P)

Sd/-16.10.2020
A.M.C.(P)

Sd/-23.10.2020
Municipal Commissioner

बृहन्मुंबई महानगरपालिका

परिपत्रक

प्र.ले./वित्त/प्रकल्प/ 25 दि. 12/07/2022

विषय: महानगरपालिकेद्वारे हाती घेण्यात येणारी विविध प्रकल्प कामे तसेच प्राप्त करण्यात येणा-या वस्तु व सेवा इत्यादीबाबतच्या ई-निविदा/निविदा/दरपत्रक यामध्ये वस्तु व सेवा कराच्या अनुषंगाने अंतर्भूत करावयाच्या अटीबाबत.

संदर्भ: १) प्र.ले./वित्त/प्रकल्प/शहर/३३ दि.०४.०३.२०१७

२) प्र.ले./वित्त/प्रकल्प/शहर/१२०अे दि.०८.०५.२०१७

३) प्र.ले./वित्त/प्रकल्प/शहर/८ दि.१४.०७.२०१७

४) प्र.ले./वित्त/प्रकल्प/शहर/२८ दि.२०.११.२०१७

५) Press Release: 47th Meeting of the GST Council, Chandigarh
28th and 29th June, 2022.

बृहन्मुंबई महानगरपालिकेद्वारे हाती घेण्यात येणाऱ्या विविध प्रकल्प कामे तसेच प्राप्त करण्यात येणा-या वस्तु व सेवा इत्यादीबाबतच्या ई-निविदा/निविदा/दरपत्रक यामध्ये वस्तु व सेवा कराच्या अनुषंगाने अंतर्भूत करावयाच्या अटीबाबत संदर्भित परिपत्रकान्वये सूचना प्रसृत केल्या आहेत.

वस्तु व सेवाकरांच्या दरात फेरबदल करण्याबाबत शासन विचाराधीन असल्याने महानगरपालिकेतील विविध कामांच्या निविदांबाबत संभाव्य निविदाकार महापालिकेस निवेदन सादर करत आहेत. अतएव, महानगरपालिकेद्वारे हाती घेण्यात येणारी विविध प्रकल्प कामे तसेच प्राप्त करण्यात येणा-या वस्तु व सेवा इत्यादीबाबतच्या ई-निविदा/निविदा/दरपत्रक यामध्ये संदर्भित क्र.५ अन्वये दिलेल्या वस्तु व सेवा कराच्या अनुषंगाने अंतर्भूत करावयाच्या अटीमध्ये खालीलप्रमाणे बदल करण्यात येत आहे.

विद्यमान अट	सुधारित अट
<p>“GST and other state levies/cess which are not subsumed under GST will be applicable. The tenderer shall quote inclusive of all taxes. It is clearly understood that BMC will not bear any additional liability towards payment of any Taxes & Duties.</p> <p>Wherever the services to be provided by the Tenderers, falls under Reverse Charge Mechanism, the Price quoted shall be exclusive of GST, but inclusive of Taxes/Duties/Cess other than GST, if any.</p> <p>Rates accepted by BMC shall hold good till completion of work and no additional individual claim shall be admissible on account of fluctuations in market rates; increase in taxes/any other levies/tolls etc. except that payment/recovery for overall market situation shall be made as per Price variation.</p>	<p>“GST and other state levies/cess which are not subsumed under GST will be applicable. The tenderer shall quote inclusive of all taxes <u>applicable at the time of bid submission</u>. It is clearly understood that BMC will not bear any additional liability towards payment of any Taxes & Duties.</p> <p>Wherever the services to be provided by the Tenderers, falls under Reverse Charge Mechanism, the Price quoted shall be exclusive of GST, but inclusive of Taxes/Duties/Cess other than GST, if any.</p> <p>Rates accepted by BMC shall hold good till completion of work and no additional individual claim shall be admissible on account of fluctuations in market rates; increase in taxes/any other levies / tolls etc. except that payment/recovery for overall market situation shall be made as per Price variation and if there is any subsequent change (after submission of bid) in rate of GST applicable on the work/services to be executed as per tender, i.e. any increase will be reimbursed by BMC whereas any reduction in the rate of GST shall be passed on to BMC as per the provisions of the GST Act.</p>

उपरोक्त सुधारीत अट ही ज्या कामांच्या ई-निविदा/निविदा/दरपत्रक दस्तऐवज यामध्ये समाविष्ट केलेली असेल फक्त त्याच कामांकरिता लागू असेल.

अतएव, प्राप्त होणारे देकार प्रचलित वस्तु व सेवा करांच्या दरानुसार प्राप्त होणार असल्याने, सध्या ज्या ई-निविदा/निविदा/दरपत्रक मागविलेल्या आहेत अशा निविदांमध्ये

नियत दिनांकापूर्वी शुद्धीपत्रकाद्वारे उपरोक्त सुधारीत अट समाविष्ट करण्याबाबत तसेच यापुढे मागविण्यात येणाऱ्या ई-निविदा/निविदा/दरपत्रक यांमध्ये उपरोक्त सुधारीत अट समाविष्ट करण्याची संबंधित खातेप्रमुख यांनी दक्षता घ्यावी, तसेच वस्तु व सेवा कराच्या दरातील बदल हा शासन निर्णयामधील दिनांकापासून प्रभाव्य राहिल.

सर्व खातेप्रमुख, रूग्णालयांचे अधिष्ठाता, सहायक आयुक्त, यांनी उपरोक्त सुचनांचे काटेकोरपणे अनुपालन करावे.

99/06/22

(पांडुरंग गोसावी)

प्रमुख लेखापाल (सा.पु.म.नि.)

99/06/22

(प्रदिप पडवळ)

प्रमुख लेखापाल (वित्त) प्र.

99/06/2022.

(रामदास आक्हाड)

उप आयुक्त (वित्त)

99/06/22

(पी. डी. पारस) 774
अतिरिक्त आयुक्त (प्रकल्प)

MUNICIPAL CORPORATION OF GREATER MUMBAI

No.: Ch.E./S.O./ 8963 Dt. 12 FEB 2021 19 MAY 2021

Sub. : Strengthening, Improvement & Maintenance of Various Roads & Junctions in Cement Concrete / Asphalt in Mumbai City, Eastern & Western Suburbs.

Ref. : Circular No. MGC/F/3291 Dated 19.09.2014

With respect to above subject matter, it is to be mentioned here that Roads department has undertaken the work Strengthening, Improvement & Maintenance of Various Roads & Junctions in Cement Concrete / Asphalt in Wards in Mumbai City, Eastern & Western Suburbs in fair season of year 2020-21. Many of these roads are being improved majorly in Cement Concrete. The staff of Roads deptt., Ward staff and other Central agency staff including Sewerage Operation deptt. are carrying out joint inspections of utilities before commencement of road improvement work to avoid further inconvenience. However, it is noticed that staff of Roads deptt. & Ward staff insists Sewerage Operation deptt. to carry out various repairs of sewer utilities on last moment during execution of work saying that there is no provision made for new sewerage utility works / rectification works of sewer utilities damaged during road improvement works.

It is to be stated that Sewerage Operation (S.O.) deptt. carry out work of maintenance of Sewer lines by means of various mechanical machineries and only minor remedial measure civil works through contractor appointed by S.O. deptt. However the major remedial works and replacement / diversion of sewer lines along with all street connections & relocation sewer utilities viz. manholes / vent shafts etc. does not falls in the purview of Sewerage Operation deptt.

It is further to be stated here that road improvement works fall under project works and therefore all necessary new sewerage utility works, unforeseen rectification works of damaged sewer utilities during road improvement works etc. shall be considered for estimation while inviting tenders of road improvement works in consultation with Sewerage Operation / Sewerage Project deptt.

Presently improvement of various roads in Cement Concrete / Asphalt in Mumbai City, Eastern & Western Suburbs areas have been undertaken by Ch.E.(Roads) deptt. & same are in progress. Some urgent nature of Sewerage Remedial Works are needs to be carried out simultaneously during the road improvement works duly in coordination with concerned E.E.(Civil)S.O. / E.E.Mech.(M.S.) City / E.S. / W.S. to avoid further inconvenience in Sewerage Remedial Works / maintenance of sewer line network and damages to improved roads.

In light of the above, Ch.E.(Roads) is hereby requested to instruct concerned staff to include new sewerage utility works, unforeseen rectification works of damaged sewer utilities in scope of road improvement works with prior joint site visit / inspection of roads before inviting tenders in future and execute urgent nature of Sewerage Remedial Works from their ongoing road contracts as per the site requirements. The above said S.O.P. as per Circular under reference is required to be followed scrupulously.

Treat this as "Most Urgent" please.

11.02.2021
(S. D. Chavan)
Chief Engineer
(Sewerage Operation) /c

(R. P. Talkar)
Chief Engineer (Roads)

3)

बृहन्मुंबई महानगरपालिका
 प्रमुख अभियंता (रस्ते वाहतूक)
 यांचे कार्यालय (SP)
 19 MAY 2021
 क्र.प्र.अ.(रस्ते)/ 950

Ch. Eng. (Rds) City / W/S / E.S. / Traffic/Planning

२५/५/२१

HE

Ch. Eng. (Roads & Traffic)

उपप्रमुख अभियंता
 रस्ते
 (प उ) यांचे कार्यालय (SP)
 दिनांक 28 MAY 2021
 उ.प अभि 1780
 रस्ते.....

E.E. (Rds) - III (K/E, H/E. & H/W)
 E.E. (Rds) - IV (K/W, S/S & P/N)
 E.E. (Rds) Z-VII (R/S, R/C & P/N)
 A.E. (Rds) W.Sub.
 A.O. (Rds) W. Sub.
 H.C. (Rds) Exp. /
 For Necessary Action & Report
 ADDy. Ch. Eng. (Rds) W.Sub.

A.E. (Rds) R/S, R/C, R/N
 For early n/a please
 108/203/06/21
 E. E. (Rds) Z-VII W.Sub

MUNICIPAL CORPORATION OF GREATER MUMBAI

No.AMC/P/7909 of 05.01.2021

CIRCULAR

In the last few years, the singular issue of pothole ridden roads in Mumbai region during the Monsoon season has proven to be a huge bane from both the administration and citizens standpoint. To overcome this issue, a policy has been recently adopted by the Corporation to undertake new improvement of roads in Cement Concrete wherever possible in a phase wise manner.

However, the decision to undertake all major improvements of roads in Cement Concrete has also relatively brought to the fore the issue of Trenching Activities for underground utilities which are so frequently prevalent in a continuously developing Mumbai region. It is a well noted fact that the frequent trenching of roads has been at the outset one of the major causes for decreasing the design life of roads and the resultant occurrence of potholes on the affected roads.

In the given context, for the success of the policy decision to improve all major roads in CC surface, it is imperative that the Trenching activities for underground utilities are to a great extent abated if not completely stopped.

In above regards, Consultants are appointed by the Corporation to design underground utility ducts to be provided along both the sides and across of the proposed CC roads in Mumbai region.

In light of the foregoing consideration, it is hereby directed that henceforth all new roads to be improved in CC surface from here on shall mandatorily provide along both sides and across at regular intervals of not more than 100 mtrs, Underground Ducts for laying /shifting existing and new utilities.

Similarly in case, where the shifting of utilities by an external agencies in the proposed underground utility ducts is concerned, the cost and risk will have to be borne entirely by the respective external agencies.

The above order will also be applicable in toto for all tenders invited and passed in Standing Committee recently.

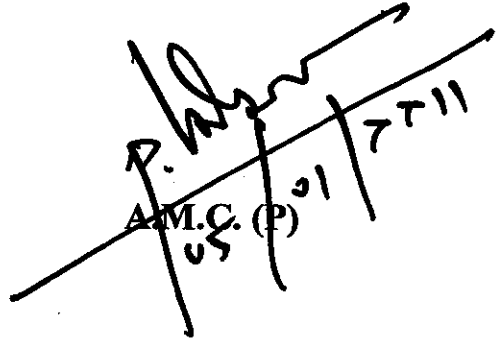
A handwritten signature in black ink is written over a diagonal line. Below the signature, the text 'AMC. (P)' is written, followed by the date '05/01/2021'.

To

D.M.C. (Infra)
CE(SWD)/CE(Bridges)/CE(Roads)
CE(MSDP)/CE(SP)/CE(SO)/CE(M&E)
CE(WSP)/H.E.

संयुक्त संवैधानिक

पान
14/11/11

संविधान, 1950, अनुच्छेद 1(1), (2) -

१. एक संघीय लोकतान्त्रिक गणतन्त्र देश असेल अशा संविधानाच्या अधीन येणारे क्षेत्रांत कितीही प्रदेश असल्यास ते एक संघ राज्यक्षेत्र म्हणून संविधानाच्या अधीन येतील. (1)

२. संघ राज्यक्षेत्रात कितीही प्रदेश असल्यास ते संघ राज्यक्षेत्र म्हणून संविधानाच्या अधीन येतील. (2)

ही संघीय संरचना ही संघीय संरचना असणे आवश्यक आहे. या संघीय संरचनेत कितीही प्रदेश असल्यास ते संघ राज्यक्षेत्र म्हणून संविधानाच्या अधीन येतील. (3)

१. संघीय संरचना ही संघीय संरचना असणे आवश्यक आहे. या संघीय संरचनेत कितीही प्रदेश असल्यास ते संघ राज्यक्षेत्र म्हणून संविधानाच्या अधीन येतील. (4)

१. संघ राज्यक्षेत्रात कितीही प्रदेश असल्यास ते संघ राज्यक्षेत्र म्हणून संविधानाच्या अधीन येतील. (5)
२. संघ राज्यक्षेत्रात कितीही प्रदेश असल्यास ते संघ राज्यक्षेत्र म्हणून संविधानाच्या अधीन येतील. (6)

1. वर्षा ऋतु में पौधों की वृद्धि अधिक होती है।
 2. पौधों की वृद्धि के लिए पानी और पोषक तत्वों की आवश्यकता होती है।
 3. पौधों की वृद्धि के लिए सूर्य की रोशनी भी आवश्यक है।
 4. पौधों की वृद्धि के लिए तापमान भी महत्वपूर्ण है।
 5. पौधों की वृद्धि के लिए वायुमंडल में कार्बन डायऑक्साइड की आवश्यकता होती है।

6. पौधों की वृद्धि के लिए जल और पोषक तत्वों का संचरण आवश्यक है।
 7. पौधों की वृद्धि के लिए सूर्य की रोशनी का संचरण भी आवश्यक है।



बृहन्मुंबई महानगरपालिका

परिपत्रक

२०२०-२१

क्र.प्रले(वित्त)/प्रकल्प/२१ दिनांक ०७.०६.२०२०

विषय: बृहन्मुंबई महानगरपालिकेची कामे करणाऱ्या कंत्राटदारांना चालू कंत्राटांमधील अडचणीबाबत उपाययोजना व सहाय्य करणे
(Contract Deposit and Retention Money)

- संदर्भ: १) महाराष्ट्र शासन परिपत्रक क्रमांक संकीर्ण-१०२०/प्र.क्र./१००/२०२० -व्यय -१२ दिनांक २९ जूलै, २०२०
२) क्र.उपप्रले/व्यय/१/०६ दिनांक १०.०८.२०२०
३) क्र.प्रले(वित्त)/प्रकल्प/२० दिनांक २०.०८.२०२०

केंद्र सरकार व राज्य सरकारने 'कोविड-१९' या महासाधीच्या कालावधीमध्ये मार्गदर्शक सूचना जारी करून लॉकडाऊन जाहीर केले. लॉकडाऊनच्या कालावधीमध्ये आपत्ती व्यवस्थापन कायदा, २००५ नुसार घातलेल्या निर्बंधामुळे बृहन्मुंबई महानगरपालिकेमार्फत राबविण्यात येणाऱ्या प्रकल्पांची गती मंदावली आहे. महाराष्ट्र शासनाने परिपत्रक क्र.संकीर्ण-१०२०/प्र.क्र.१००/२०२०/व्यय१२ दिनांक २९.०७.२०२० च्या अनुषंगाने तसेच कार्यानुरूप हमी परत करून सहाय्य करण्याच्या अनुषंगानेही संदर्भित परिपत्रक प्रसारीत केलेले आहे. तथापि, याबाबत आणखी प्राप्त झालेल्या सूचना/मार्गदर्शन यानुसार सदर धोरण निश्चित करण्यात येत आहे.

बृहन्मुंबई महानगरपालिकेमध्ये सध्या प्रकल्प व इतर कामांकरिता खालीलप्रमाणे सुरक्षा अनामत रक्कम व रिटेंशन मनी प्राप्त करण्यात येत आहेत:-

तक्ता क्रमांक - १

अनु. क्र.	सुरक्षा अनामत रकमेचा प्रकार	टक्केवारी	रक्कमेचे स्वरूप	परतावा निकष
१.	कंत्राट/सुरक्षा अनामत रक्कम (कॉन्ट्रॅक्ट सम वर)	२% व त्यापेक्षा जास्त	बँक हमीपत्र	दोष दायित्व कालावधी १/२/३ वर्षे असल्यास दोष दायित्व कालावधी संपल्यानंतर आणि दोष दायित्व कालावधी ५ वर्षे असल्यास दोष दायित्व कालावधीच्या ३ वर्षांनंतर.

२.	रिटेंशन मनी (कॉन्ट्रॅक्ट सम वर)	चालू देयकातून ५%	अ) रोख (देयकातून वळती) ब) बँक हमीपत्रामध्ये परावर्तीत केलेली	५०% काम पूर्ततेनंतर व उर्वरित ५०% दोष दायित्व कालावधी १/२/३ वर्षे असल्यास दोष दायित्व कालावधी संपल्यानंतर आणि दोष दायित्व कालावधी ५ वर्षे असल्यास दोष दायित्व कालावधीच्या ३ वर्षांनंतर.
३.	परफॉर्मन्स गॅरंटी (कॉन्ट्रॅक्ट सम वर)	निविदा दरात अधिमुल्य/सममुल्य व १२% पर्यंत सूट असल्यास ०.९२% १२% पेक्षा जास्त सूट असल्यास ०.९२% अधिक १२% पेक्षा जास्त सूटीचा टक्का किंवा त्याचा भाग यास १% या प्रमाणे	बँक हमीपत्र स्वरूपात	दोष दायित्व कालावधी संपल्यानंतर.
४.	अतिरिक्त सुरक्षा अनामत रक्कम (ASD) (कार्यालयीन अंदाजावर)	निविदेत प्रतिसाद १२% रकमेपेक्षा जास्त सूट दिल्यास प्रत्येक टक्का किंवा त्याच्या भागास १% प्रमाणे	रोख (निविदा सादर करतेवेळी ऑनलाईन अधिदान.)	काम पूर्ततेनंतर.

महानगरपालिकेने राज्य शासनाच्या धर्तीवर Retention Money बँक हमीपत्रात परावर्तीत करण्याबाबत तसेच ५०% काम पुर्ण झालेले असल्यास अतिरिक्त सुरक्षा अनामत रक्कम (ASD) ५०% परत करण्यास व उर्वरित रक्कम बँक हमीपत्रात परावर्तीत करण्यास संदर्भित क्र. २ अन्वये तसेच कार्यानुरूप हमी कंत्राटदारांना परत करून सहाय्य करण्याबाबतही संदर्भित क्र. ३ अन्वये परिपत्रक प्रसारीत केलेले आहे.. त्यामुळे प्राप्त वाढीव मागणीप्रमाणे कोव्हिड-१९ मुळे उद्भवलेल्या परिस्थितीवर मात करून महानगरपालिकेतील कामे विहित वेळेत पूर्ण होण्याच्या दृष्टीने तसेच आलेल्या वेगवेगळ्या मागण्यांचा एकत्रित

विचार करून महानगरपालिकेतील कंत्राटदारांना Contract Deposit and Retention Money मध्ये खालीलप्रमाणे बदल करून अतिरिक्त सहाय्य/सवलत/परतावा देण्यात येत आहे.

तक्ता क्रमांक - २

अनु. क्र.	सुरक्षा अनामत रकमेचा प्रकार	टक्केवारी	रक्कम	परतावा निकष
१.	कंत्राट/सुरक्षा अनामत रक्कम	२%	बँक हमीपत्र	दोष दायित्व कालावधी १/२/३ वर्षे असल्यास दोष दायित्व कालावधी संपल्यानंतर आणि दोष दायित्व कालावधी ५ वर्षे असल्यास दोष दायित्व कालावधीच्या ३ वर्षांनंतर
२.	रिटेंशन मनी	२% (चालू देयक रकमेच्या)	अ)रोख (देयकातून वळती) ब)बँक हमीपत्रामध्ये परावर्तीत केलेली	५०% काम पूर्ततेनंतर व उर्वरित ५०% दोष दायित्व कालावधी १/२/३ वर्षे असल्यास दोष दायित्व कालावधी संपल्यानंतर आणि दोष दायित्व कालावधी ५ वर्षे असल्यास दोष दायित्व कालावधीच्या ३ वर्षांनंतर

तथापि, निविदाकाराने निविदा सादर करताना निविदेमध्ये नमूद असलेली सुरक्षा अनामत व रिटेंशन मनीची रक्कम विचारात घेऊन निविदेचे दर भरलेले आहे. त्यामुळे उपरोक्त तक्ता क्र. २ प्रमाणे सुरक्षा अनामत व रिटेंशन मनीची रक्कम कमी केल्यामुळे निविदाकाराला नमूद दरामध्ये अतिरिक्त आर्थिक फायदा होणार आहे. त्यामुळे सदर फायदा अंदाजे किती होणार आहे हे निश्चित करून कंत्राटदाराची bid price त्याप्रमाणात कमी करणे आवश्यक आहे. सदर रकमेच्या परिगणनासाठी खालीलप्रमाणे काही धारणा (assumptions) गृहीत धरल्या आहेत :-

I) स्थायी धारणा (fixed assumptions)

१. व्याजाचा दर द.सा.द.शे. ६%
२. बँक गॅरंटी प्राप्त करण्यासाठी १/३ कॅश मार्जिन
३. समान रकमेचे तिमाही अधिदान

II) अस्थायी धारणा (variable assumptions)

१. कंत्राट रक्कम
२. कंत्राट कालावधी
३. दोष दायित्व कालावधी
४. सुरक्षा अनामत रक्कम/रिटेंशन मनी

प्रत्येक कामाचा कंत्राट कालावधी वेगवेगळा राहणार असल्यामुळे त्या प्रत्येक कामासाठी परिगणित होणाऱ्या फायद्याची रक्कम वेगवेगळी असणार आहे. त्यासाठी आजच्या तारखेला बाजारभावानुसार असणारे निव्वळ वर्तमान मूल्य (NPV) विचारात घेण्यात आलेले आहे. अशाप्रकारचे परिगणन करण्यासाठी वापरावयाचे सूत्र (Formula) खालीलप्रमाणे आहे :-

$$\text{Discount Rate} = \frac{\text{NPV as per Table-I} \times 100}{\text{(Total NPV of quarterly bills of Balance Contract Cost)}}$$

याबाबतचे उदाहरणादाखल Annexure 'A', 'B', 'B-1', 'C', 'C-1' and 'D' सोबत जोडले आहे.

उपरोक्त धारणांच्या (assumptions) आधारे कंत्राट अनामत रक्कम, रिटेंशन मनी यापैकी एका किंवा दोन्ही बाबींसाठी NPV च्या आधारे परिगणित होणाऱ्या टक्केवारीनुसार अंशतः भरपाई (offset) देऊन संबंधित कंत्राटदार प्रस्तावित सवलत घेऊ शकतो. त्याकरिता चालू कंत्राटामधून अतिरिक्त सूट देण्यास सहमत असल्याचे व कर रचनेत कोणताही बदल झाला तरी सदर सूट रक्कम वसूल करण्यास हरकत नसल्याबाबतचे रु. ५००/- च्या स्टॅम्प पेपरवर प्रतिज्ञापत्र कंत्राटदाराने देणे आवश्यक असेल. अशी सवलत घेण्यासाठी कंत्राटदाराने संबंधित खाते प्रमुखांकडे लेखी अर्ज करणे अनिवार्य असेल. तदनंतर, संबंधित खाते प्रमुखाने प्रकरणाविषयी परिगणन करून त्यांच्या शिफारसीसह संबंधित प्रकरण सक्षम प्राधिकार्याच्या (संबंधित

उपायुक्त) मंजुरीकरिता प्रमुख लेखापाल (वित्त)/प्रमुख लेखापाल (पा.पु.म.नि.) खात्याच्या लेखा विभागामार्फत सादर करणे आवश्यक असेल.

सादर मार्गदर्शक सूचना या महानगरपालिकेच्या हाती घेण्यात आलेल्या रु.५० लाखापेक्षा अधिक कंत्राट किंमत असलेल्या प्रकल्प व इतर कामांच्या कंत्राटांना लागू राहतील. तथापि महापालिकेच्या ज्या कंत्राटदारांविरुद्ध ज्या कामांकरिता विविध चौकशी प्रलंबित आहे अशा कंत्राटदारांना त्या कामाकरिता तसेच तद्अनुषंगाने इतर कामातून रोखून ठेवलेल्या रकमांना सुध्द या सवलती लागू होणार नाहीत. तसेच यापुढील कामाकरिता मसुदानिविदेत परिपत्रकात नमूद केल्याप्रमाणे सुधारित टक्केवारीनुसार कंत्राट सुरक्षा अनामत आणि रिटेशन मनी बाबतची अट अंतर्भूत करणे आवश्यक असेल.

प्रमुख लेखापाल (पा.पु.म.नि.)
२५/८/२०२०.

प्रमुख लेखापाल (वित्त)प्र.
२५/८/२०२०.

अतिरिक्त आयुक्त (प्रकल्प)

महानगरपालिका आयुक्त

२७/८-२०.

4-399
99e

Annexure-A
I-Contract Deposits/ Security Deposits

Example:

(Amount in Crore)

Particular	As per Tender Condition	Revised	Margin Difference	Net '00 6% Interest Rate	NPV
Contractor %	-13.00%				
Contract Sum	100.0000				
Work Done-Amount (Financial Progress)	0.0000				
Balance Contract Cost	100.0000				
Contract Period (in Year)	4.00				
Work Done-Period (in Year)	0.00				
Balance Contract Period (in Year)	4.00				
DLP Period (in Year)	5.00				
Contract Deposit Amount	5.0000	2.0000			
Interest Rate	6.00%				
Bank Guarantee is issued @ 3% Bank Commission as against 1/3 cash margin required for issuance of Bank Guarantee	1.6667	0.6667	1.0000	0.5172	0.4200
				NPV-I	0.4200

Annexure-B

II- Retention Money (Cash)

(Amount in Crore)

Example:

Particular	As per Tender Condition	Revised	RM Relief	Amount as per @6%	Total RM relief	NPV
Balance Contract Cost	100.0000					
Balance Contract Period (In Year)	4.00					
DLP Period (in Year)	5.00					
Quarterly Payment Will be released	6.2500					
Interest Rate	6.00%					
% of Retention Money for each Bill	5.00%	2.00%				
	0.3125	0.1250				
Total Retention money	5.0000	2.0000				
Quarterly Break-up of RM						
1	0.3125	0.1250	0.1875	0.0028	0.1903	0.0028
2	0.3125	0.1250	0.3778	0.0029	0.3807	0.0028
3	0.3125	0.1250	0.5682	0.0057	0.5739	0.0055
4	0.3125	0.1250	0.7614	0.0086	0.7700	0.0082
5	0.3125	0.1250	0.9575	0.0115	0.9690	0.0109
6	0.3125	0.1250	1.1565	0.0145	1.1711	0.0135
7	0.3125	0.1250	1.3586	0.0176	1.3761	0.0161
8	0.3125	0.1250	1.5636	0.0206	1.5843	0.0186
9	0.3125	0.1250	1.7718	0.0238	1.7955	0.0211
10	0.3125	0.1250	1.9830	0.0269	2.0100	0.0236
11	0.3125	0.1250	2.1975	0.0301	2.2276	0.0260
12	0.3125	0.1250	2.4151	0.0334	2.4485	0.0281
13	0.3125	0.1250	2.6360	0.0367	2.6728	0.0307
14	0.3125	0.1250	2.8603	0.0401	2.9004	0.0330
15	0.3125	0.1250	3.0879	0.0435	3.1314	0.0353
16	0.3125	0.1250	3.3189	0.0470	3.3658	0.0376
17			3.3658	0.0505	3.4163	0.0398
18			3.4163	0.0512	3.4676	0.0398
19			3.4676	0.0520	3.5196	0.0398
20			3.5196	0.0528	3.5721	0.0398
21			3.5724	0.0536	3.6260	0.0398
22			3.6260	0.0544	3.6804	0.0398
23			3.6804	0.0552	3.7356	0.0398
24			3.7356	0.0560	3.7916	0.0398
25			3.7916	0.0569	3.8485	0.0398
26			3.8485	0.0577	3.9062	0.0398
27			3.9062	0.0586	3.9648	0.0398
28			3.9648	0.0595	4.0243	0.0398
	5.0000	2.0000	71.0961	1.0243	72.1204	0.7915
					NPV-II	0.7915

The balance Retention Money shall be released within 30 days after completion of 3rd year of DLP (in case of 5 years DLP)
 or
 after issue of 'Defect Liability Certificate' (in case of 1 or 2 or 3 years DLP)

V-924
922

EXAMPLE

Annexure-B-I (where Retention Money is Cash)

Table-I- Summary of NPV

Particular	NPV
I-Contract Deposits/ Security Deposits (as per Annexure-A)	0.4200
II- Retention Money (as per Annexure-B)	0.7915
Total NPV	1.2115

Table-II- Discount per Bill as per NPV

(Amount in Crore)

No of Quarters	Quarterly Break-up of Payment	NPV of Bill Amount
1	2	3 (NPV of Column no. 2)
1	6.2500	6.2500
2	6.2500	6.1576
3	6.2500	6.0666
4	6.2500	5.9770
5	6.2500	5.8887
6	6.2500	5.8016
7	6.2500	5.7159
8	6.2500	5.6314
9	6.2500	5.5482
10	6.2500	5.4662
11	6.2500	5.3854
12	6.2500	5.3058
13	6.2500	5.2274
14	6.2500	5.1502
15	6.2500	5.0741
16	6.2500	4.9991
	100.0000	89.6452

Formula:- Discount Rate

Balance Contract Cost	=	100.0000
NPV as per Table-I	=	1.2115
Total NPV of quarterly bills	=	89.6452

$$\text{Discount Rate} = \frac{\text{NPV as per Table-I} \times 100}{(\text{Total NPV of quarterly bills of Balance Contract Cost})}$$

$$= \frac{1.2115 \times 100}{89.6452}$$

$$= 1.35$$

Annexure-C

II- Retention Money Against BG

Example:

(Amount in Crore)

Particular	As per Tender Condition	Revised	RM Relief Margin money	Amount as per @6% Interest	Total RM relief	NPV
Balance Contract Cost	100.0000					
Balance Contract Period (in Year)	4.00					
DLP Period (in Year)	5.00					
Quarterly Payment Will be released	6.2500					
Interest Rate	6.00%					
% of Retention Money for each Bill	5.00%	2.00%				
	0.3125	0.1250				
Total Retention money	5.0000	2.0000				
Quarterly Break-up of RM						
1	0.3125	0.1250	0.0625	0.0009	0.0634	0.0009
2	0.3125	0.1250	0.1259	0.0010	0.1269	0.0009
3	0.3125	0.1250	0.1894	0.0019	0.1913	0.0018
4	0.3125	0.1250	0.2538	0.0029	0.2567	0.0027
5	0.3125	0.1250	0.3192	0.0038	0.3230	0.0036
6	0.3125	0.1250	0.3855	0.0048	0.3904	0.0045
7	0.3125	0.1250	0.4529	0.0059	0.4587	0.0054
8	0.3125	0.1250	0.5212	0.0069	0.5281	0.0062
9	0.3125	0.1250	0.5906	0.0079	0.5985	0.0070
10	0.3125	0.1250	0.6610	0.0090	0.6700	0.0079
11	0.3125	0.1250	0.7325	0.0100	0.7425	0.0087
12	0.3125	0.1250	0.8050	0.0111	0.8162	0.0095
13	0.3125	0.1250	0.8787	0.0122	0.8909	0.0102
14	0.3125	0.1250	0.9534	0.0134	0.9668	0.0110
15	0.3125	0.1250	1.0293	0.0145	1.0438	0.0118
16	0.3125	0.1250	1.1063	0.0157	1.1219	0.0125
17			1.1219	0.0168	1.1388	0.0133
18			1.1388	0.0171	1.1559	0.0133
19			1.1559	0.0173	1.1732	0.0133
20			1.1732	0.0176	1.1908	0.0133
21			1.1908	0.0179	1.2087	0.0133
22			1.2087	0.0181	1.2268	0.0133
23			1.2268	0.0184	1.2452	0.0133
24			1.2452	0.0187	1.2639	0.0133
25			1.2639	0.0190	1.2828	0.0133
26			1.2828	0.0192	1.3021	0.0133
27			1.3021	0.0195	1.3216	0.0133
28			1.3216	0.0198	1.3414	0.0133
	5.0000	2.0000	23.6987	0.3414	24.0401	0.2638
					NPV-II	0.2638

The balance Retention Money shall be released within 30 days after completion of 3rd year of DLP (in case of 5 years DLP)
 or
 after issue of 'Defect Liability Certificate' (in case of 1 or 2 or 3 years DLP)

प-१३१
१२६०

Annexure-C-I (where Retention Money is BG)

EXAMPLE.

Table-I- Summary of NPV

Particular	NPV
I-Contract Deposits/ Security Deposits (as per Annexure-A)	0.4200
II- Retention Money against BG (as per Annexure-C)	0.2638
Total NPV	0.6838

Table-II- Discount per Bill as per NPV

(Amount in Crore)

No of Quarters	Quarterly Break-up of Payment	NPV of Bill Amount
1	2	3 (NPV of Column no. 2)
1	6.2500	6.2500
2	6.2500	6.1576
3	6.2500	6.0666
4	6.2500	5.9770
5	6.2500	5.8887
6	6.2500	5.8016
7	6.2500	5.7159
8	6.2500	5.6314
9	6.2500	5.5482
10	6.2500	5.4662
11	6.2500	5.3854
12	6.2500	5.3058
13	6.2500	5.2274
14	6.2500	5.1502
15	6.2500	5.0741
16	6.2500	4.9991
	100.0000	89.6452

Formula:- Discount Rate

Balance Contract Cost	=	100.0000
NPV as per Table-I	=	0.6838
Total NPV of quarterly bills	=	89.6452

$$\text{Discount Rate} = \frac{\text{NPV as per Table-I} \times 100}{(\text{Total NPV of quarterly bills of Balance Contract Cost})}$$

$$= \frac{0.6838 \times 100}{89.6452}$$

$$= 0.76$$

4
9

Annexure-D
Assumption

Particular	As per Tender Condition	Revised
Estimated Cost	114.9425	
Contractor %	-13.00%	
Contract Sum	100.0000	
Work Done-Amount (Financial Progress)	0.0000	
Balance Contract Cost	100.0000	
Contract Period (in Year)	4	
Work Done-Period (in Year)	0	
Balance Contract Period (in Year)	4	
DLP Period (in Year)	5	
Contract Deposit Amount	5.0000	2.0000
PBG Amount	1.9200	0.0000
ASD	1.1494	0.5747
% of Retention Money for each Bill	5.00%	2.00%
Interest Rate	6.00%	
Quarterly Break-up of Payment	6.2500	

पध्दती (Standard Operation Procedure) खालील प्रमाणे असेल.

क्र	तपशिल	कालावधी
१.	संबंधित कंत्राटदार/निविदाकार यांनी अशा प्रकारची सवलत घेण्याबाबत संबंधित खात्याच्या कार्यकारी अभियंत्याकडे लेखी अर्ज करणे आवश्यक असेल.	परिपत्रकाच्या दिनांकापासून एक महिन्याच्या आत
२.	कार्यकारी अभियंता यांनी परिपत्रकात नमूद केलेल्या सुत्रानुसार भरपाई (Offset) ची टक्केवारी परिगणित करून Excel Sheet सह प्रस्ताव प्रमुख अभियंताच्या शिफारशीसह प्रमुख लेखापाल (वित्त)/ प्रमुख लेखापाल (पा.पु.म.नि.) खात्याच्या संबंधित लेखा विभागाकडे अग्रेषित करावा.	५ कामकाजाचे दिवस
३.	संबंधित लेखा विभागाने पडताळणी करून प्रमुख लेखापाल (वित्त) / प्रमुख लेखापाल (पा.पु.म.नि.) यांच्या खातेनिहाय असलेल्या कोअर टिमकडे Excel Sheet पुर्नपडताळणी करिता पाठवावी.	५ कामकाजाचे दिवस
४.	प्रमुख लेखापाल (वित्त)/ प्रमुख लेखापाल (पा.पु.म.नि.) यांच्या खातेनिहाय असलेल्या कोअर टीमने अशा प्रस्तावांची पुर्नपडताळणी करून भरपाई (Offset) ची टक्केवारी अंतिमतः निश्चित करावी.	५ कामकाजाचे दिवस
५.	खात्याने परिगणित केलेली (Offset) ची टक्केवारी व प्रमुख लेखापाल (वित्त)/ प्रमुख लेखापाल (पा.पु.म.नि.) खात्यामार्फत पडताळण्यात आलेल्या (Offset) ची टक्केवारी दर्शविणारी Excel Sheet सह जर प्रकल्पाची कंत्राट सम रु १०० कोटी पेक्षा कमी असल्यास प्रमुख लेखापाल (वित्त)/ प्रमुख लेखापाल (पा.पु.म.नि.) त्यांच्या अभिप्रायासह भरपाई (Offset) च्या टक्केवारीच्या मान्यतेसाठी संबंधित उपआयुक्त/ सह आयुक्त यांच्या मान्यतेकरिता, तसेच जर कंत्राट सम रु १०० कोटी किंवा त्यापेक्षा जास्त असल्यास भरपाई (Offset) च्या टक्केवारीकरिता अति. आयुक्त (प्रकल्प) यांच्या मान्यतेकरिता सादर करतील. व मान्यता प्राप्त झाल्यानंतर प्रकरण नस्ती खाते प्रमुखाकडे अग्रेषित करतील.	५ कामकाजाचे दिवस

६.	सक्षम प्रधिकान्यांची मान्यता प्राप्त झाल्यानंतर खाते प्रमुख अशा प्रकारे अंतिम झालेली भरपाई (Offset) ची टक्केवारी संबंधित कंत्राटदार/निविदाकार यांना लेखी/ ई-मेल द्वारे कळवतील.	२ कामकाजाचे दिवस
७.	संबंधित कंत्राटदार/निविदाकार यांनी कंत्राटागधून अतिरिक्त सूट देण्यास सहमत असल्याचे व कर रचनेत कोणताही बदल झाला तरी सदर सूट रक्कम वसूल करण्यास हरकत नसल्याबाबतचे रु.५००/- च्या स्टॅम्प पेपरवर प्रतिज्ञापत्र संबंधित कार्यकारी अभियंता याच्याकडे सादर करतील	५ दिवस कामकाजाचे दिवस
८.	कंत्राटदाराने प्रतिज्ञा पत्र सादर केले असल्यास , त्या कंत्राटदारांच्या ज्या प्रकल्प कामास सदर योजना दि.०१.११.२०२० या दिनांका नंतर संपकार्यप्रणालीत प्रक्रिया होणाऱ्या देयकांना लागू असेल।	
९.	उपरोक्त मान्यतेनंतर जर कंत्राटदाराने २% पेक्षा जास्त कंत्राट सुरक्षा रक्कमेसाठी बँक हमीपत्र दिलेले असल्यास अश्या कंत्राटदाराकडून २% कंत्राट सुरक्षा रक्कमेचे बँक हमीपत्र प्राप्तकरून वाढीव बँक हमीपत्र परत करण्याची कार्यवाही करण्यात यावी.	५ दिवस कामकाजाचे दिवस
१०.	संबंधित कार्यकारी अभियंत्याने भरपाई (Offset) च्या टक्केवारीनुसार परिगणित होणारी रक्कम प्रत्येक देयकातून वसूल करून स्वतंत्र लेखाशिर्षात (G.L.code) जमा करण्याची दक्षता घ्यावी. तसेच अशा प्रकारच्या देयकातून फक्त २% रिटेशन मनी वसूल करावा.	

बृहन्मुंबई महानगरपालिका

परिपत्रक

२०१७-१८

क्र.सीए/एफबीके-३०३, दि.१७.०३.२०१८

विषय:- बँकेने दिलेले हमीपत्र (बँकर्स गॅरंटी) स्वीकारण्याबाबत.

संदर्भ:- सीए/एफबीके/२५, दि.३०.१०.२०१४

कंत्राटदार / पुरवठादार यांच्याकडून महानगरपालिकेस सादर करण्यात येणारी बँक हमीपत्रे (बँकर्स गॅरंटी) स्वीकारण्यासंदर्भात उपरोक्त संदर्भित परिपत्रकान्वये मार्गदर्शनपर सूचना निर्गमित करण्यात आल्या आहेत. आयडीबीआय बँकेकडून प्राप्त झालेल्या बँक हमीपत्रांचे (बँक गॅरंटी) रोखीकरण (Encashment) करण्याबाबत अडचणी निर्माण झाल्याचे निदर्शनास आलेले आहे. यास्तव, पुढील आदेश मिळेपर्यंत आयडीबीआय बँकेने दिलेली कोणतीही बँक हमीपत्रे (बँक गॅरंटी) स्वीकारली जाऊ नये.

तरी, सर्व खातेप्रमुख, सहाय्यक महापालिका आयुक्त आणि संबंधित यांनी वरील सुधारणेची नोंद घेऊन काटेकोरपणे अंमलबजावणी होईल याची दक्षता घ्यावी.

सही/१७.०३.२०१८
(श्री.रामदास. क. आळ्हाड)
प्रमुख लेखापाल (पा.पु.म.नि.)

सही/१७.०३.२०१८
(श्री.प्रदिप.भा.पडवळ)
प्रमुख लेखापाल (वित्त)प्र.

सही/१७.०३.२०१८
(डॉ.संजय मुखर्जी)
अतिरिक्त आयुक्त (प्रकल्प)

परिपत्रक

२०१७-१८

क्र.सीए/एफबीके-३०३, दि.१७.०३.२०१८

-----यांना प्रत (-----) अधिक प्रतींसह माहिती करिता व योग्य त्या कार्यवाही साठी पाठवित आहे.

स्वीकारिले
प्रमुख लेखापाल (वित्त)प्र. याजकरिता
२५/०३/१८
पाठिले
प्रमुख लेखापाल

D:\New Com\TANUJA\F.Y.2017-18\Bank Guarrantee circular.doc

NSCR 183-BMP-30859-2017-18-2200 Copy.

Director (E.S.P.) 6

प्रमाण कॅम्प-॥१॥
३१/३/१८
३१/३/१८



बृहन्मुंबई महानगरपालिका

क्र. संचा/असेवप्र/ 7083 / वोन दि. 03/08/2018

संदर्भ: परि.क्र. सीए/एफबीके - 303 दिनांक 17/03/2018

पृष्ठ क्र. 1 वरील संचा (असेवप्र) यांच्या दिनांक 31/3/2018 च्या आदेशानुसार प्रत माहितीसाठी व उचित कार्यवाहीसाठी कृपया अग्रेषित/ सविनय सादर.

प्रशासकीय अधिकारी
(संचालक असेवप्र) कार्यालय
03/4

नगर अभियंता
प्रमुख अभि. (रस्ते वाह)
प्रमुख अभि (पुल)
प्रमुख अभि (पजवा)
प्रमुख अभि (इप)
कार्य अभि (स्वीय) संचा
प्रशा.अधि.(संचा) व कर्मचारीवृंद
प्रशा.अधि. (तासंस) व कर्मचारीवृंद

बृहन्मुंबई महानगरपालिका
प्रमुख अभियंता (इ.प.)
05 APR 2018
वेळ:- ११, १२, १५, १७
क. 000252 II



उप. प्रमुख अभि. (संचा) व कर्मचारीवृंद
कार्य अभि. (संचा) व कर्मचारीवृंद
प्रशासकीय अधिकारी (I/II/III/IV)
kindly note & circulate to all
प्रमुख अभियंता

MUNICIPAL CORPORATION OF GREATER MUMBAI

Circular

ChE/8412/Rds &Tr dt.02.02.2019

Sub: Guidelines for construction of Footpath.

(MGC/A/8486 dt.18.01.2019)

For making Footpaths in Mumbai more “Pedestrian Friendly” following modifications are being incorporated in circular issued u.no. AMC/ES/6217/II dt. 30.06.2014 & MGC/A/8486 dt.10.08.2017 as elaborated point wise below :

1) Pedestrian Ramps at Property Gates

In Mumbai, properties are developed haphazardly. It is seen that plinth levels of many bldg are far above the abutting road edge levels. Due to same many have constructed ramps well above footpaths at plot entry (Property Gates). This causes lot of hardship for pedestrian and they are forced to used carriageway for movement.

Such illegal ramps needs to be removed and stand levels needs to be maintained at property gate for smooth movement of pedestrian as well as vehicles at entry on main carriageway. Design drawing for same is as per Annexure –A. Also, for cleaning of storm water drain below footpath at property gates, at the both ends of property gate necessary Frame covers on drains to be installed. Assistant Commissioners will be responsible for initiating action of removal of all illegal ramps constructed by developers / societies above footpaths at plot entry (Property Gates). Also Building Proposal department will verify this at the time of granting O.C. that such abrupt ramps in footpath are not provided.

In similar manner, ramps on Footpath are to be provided at Pedestrian road Crossing to ease out the pedestrian movements.

2) Using Concrete instead of Paver blocks of any type on footpath.

Vide no. MGC/A/8486 dt. 10.08.2017 Guidelines on using various types of paver blocks on footpaths are issued. As per this guideline:

- a) Roads upto 60 feet width, the slab on top of drains are constructed at footpath level to serve for pedestrian movement. The fresh concrete shall be roughened to make the footpath anti-skid/anti-slippery.
- b) Footpaths along roads with width 60 feet and above up to 90 feet shall be considered for fixing lacquer finish paver blocks.
- c) For footpaths with width 3M and more and for footpaths along roads with width 90 feet and more, items RW- 3.28, RW-3.30 i.e. Providing & fixing shot blasted concrete paver blocks measurement 200 x 2000 x60 mm, 100 x 100 x 60 mm and RW-39 i.e. providing & fixing Combi- Paver shot blasted 60 mm thick combination size 100 x 200, 125 x 200,

175 x 200, 225 x 200, 275 x 200 shall be operated. As general practice, the item of paver blocks of size 400 mm x 400 mm x 60 mm shall be avoided.

It is general observed that due to constantly arising defects due to paver blocks, quick & lasting maintenance of damaged paver blocks does not often occur resulting in pedestrians forced to use road carriageway. It is therefore felt to phase out the use of paver blocks use for footpath completely. In place of lacquer finish paver blocks & shot blasted concrete paver blocks following alternatives are used.

A) Stencil Concrete

For all roads having drain in footpath R.C.C.slab of thickness 150 mm will be raised upto footpath top to full width of footpath in M-20 concrete in such a way that height of footpath above finished road level is not more than 150mm except at plot entry/ Property gate. For footpath not having storm water drain beneath it / dummy footpath, M-20 concrete of thickness 125 mm will be provided except at plot entry/ Property gate. The transverse joints shall be provided along the width at every chamber by making necessary cutting for same. The plot entry/ Property gate M-40 grade concrete to be used. Stencil pattern & colour as approved by executive engineer will be provided in freshly laid above said concrete footpath. Extra over for Stencil pattern & colour, newly created item in USOR shall be operated.

B) C.C with Top in Marble chips finishing

For all roads having drain in footpath drain R.C.C.slab of thickness 150 mm will be raised up to footpath top to full width of footpath in M-20 concrete in such a way that height of footpath above finished road level is not more than 150mm except at plot entry/ Property gate. For footpath not having storm water drain beneath it / dummy footpath, M-20 concrete of thickness 125 mm will be provided except at plot entry/ Property gate where no chips will be laid.. The transverse joints shall be provided along the width at every chamber by making necessary cutting for same. The plot entry/ Property gate M-40 grade concrete to be used. Marble Chips of size & pattern as per the item will be provided in freshly laid above said concrete footpath. Extra over for the same, newly created item in USOR. shall be operated.

C) Plain C.C with brooming texture

For all roads having drain in footpath drain R.C.C.slab of thickness 150 mm will be raised upto footpath top to full width of footpath in M-20 concrete in such a way that height of footpath above finished road level is not more than 150mm except at plot entry/ Property gate. For footpath not having storm water drain beneath it / dummy footpath, M-20 concrete of thickness 125 mm will be provided except at plot entry/ Property gate. The

transverse joints shall be provided along the width at every chamber by making necessary cutting for same. The plot entry/ Property gate M-40 grade concrete to be used. Brooming texture shall be provided on finished top concrete surface.

As improvement of footpaths in above types is highly skill work and needs at most supervision, execution of same needs to be stream line. On basis of footpath width it can be decided the type of treatment to be used as mentioned in table below:

TABLE - A

Width of Footpath	Proposed Treatment for Improvement of Footpath	Execution of Work
Less than 2.0 mtrs.	C.C with Top in Marble chips finishing OR Plain C.C with brooming texture	1) For all project roads under taken by central agency. 2) Improvement of Footpath 'End to End' on any road by central agency. 3) Improvement of Footpath where trench is permitted End to End by ward will be improved by ward.
2.0mtrs and more	Stencil Concrete OR C.C with Top in Marble chips finishing OR Plain C.C with brooming texture	1) For all project roads under taken by central agency. 2) Improvement of Footpath 'End to End' on any road by central agency. 3) Improvement of Footpath where trench is permitted End to End by ward will be improved by ward.

At present wherever the footpath works are undertaken by central agency and which are partially started or not started on site with the paver blocks / short blast paver blocks, all such works shall be converted as per this policy and paver block items will be in saving and the finishing will be carried out as per the policy. The regular extra / excess /saving will be submitted as per policy for all such works separately.

In case of reinstatement of trenches, the reinstatement charges are recovered as per the existing surface of footpath and the reinstatement will be carried out as per Table –‘A’. There will not be any changes in the recovery of reinstatement charges from utility but the reinstatement will be carried out as per this policy.

Above modifications to be implemented for all forthcoming tenders henceforth.

Sd/-
30.11.2018
Ch.Eng.(Roads & Tr.)

Sd/-
10.12.2018
AMC(ES)

Sd/-
18.01.2019
Hon. M.C.

ANNEXURE -A

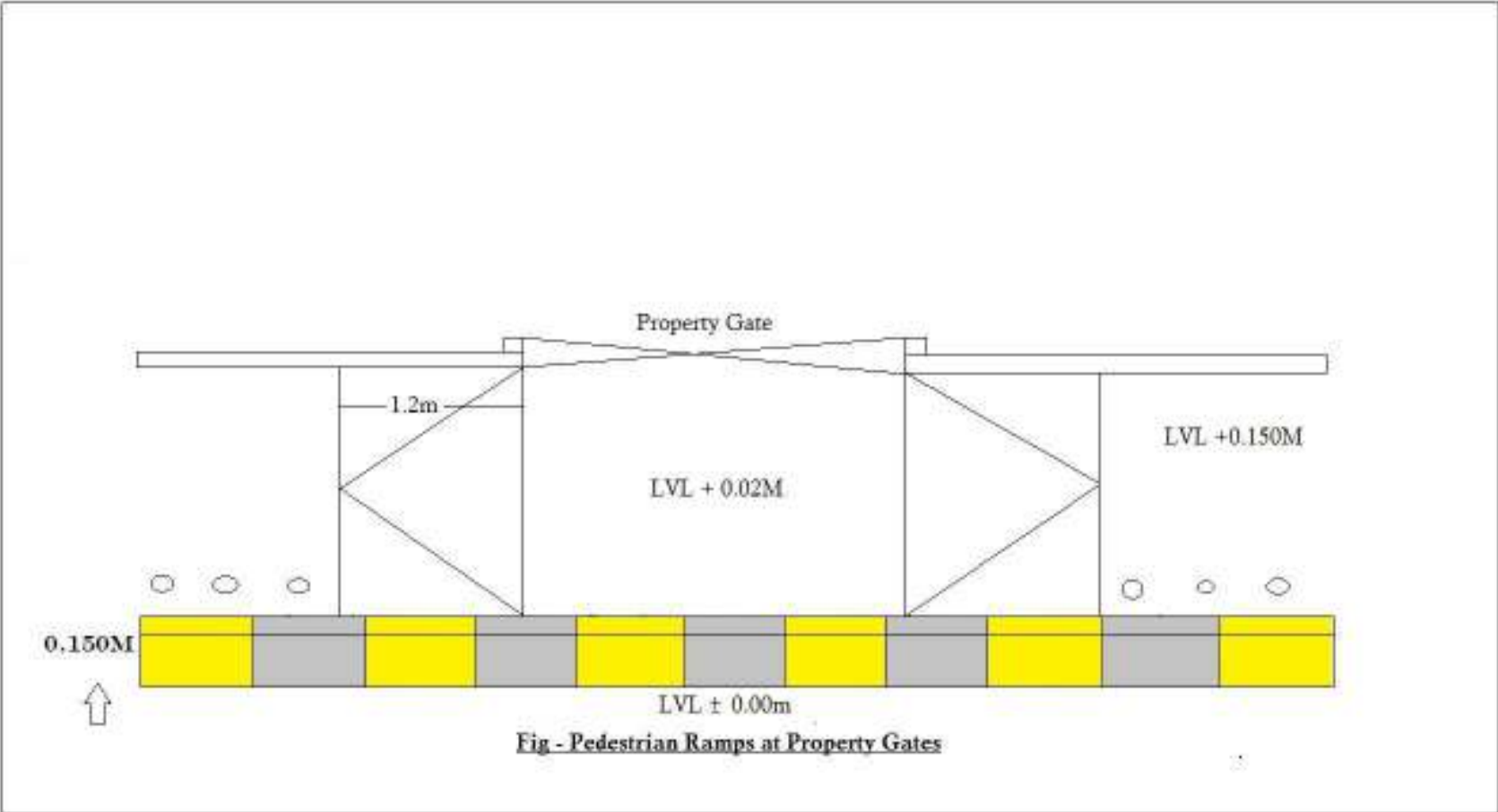

Fig - Pedestrian Ramps at Property Gates

ANNEXURE -A

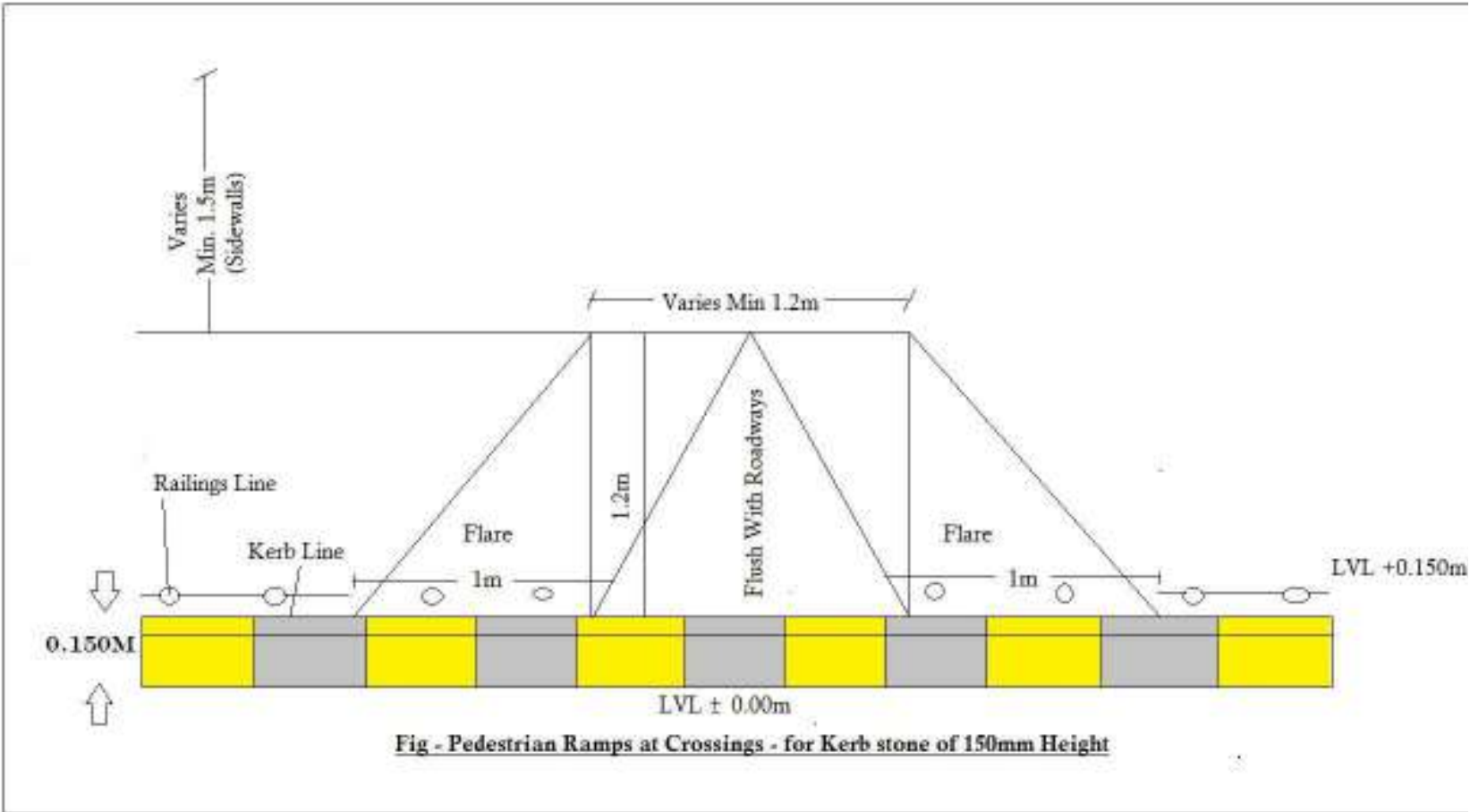

Fig - Pedestrian Ramps at Crossings - for Kerb stone of 150mm Height

MUNICIPAL CORPORATION OF GREATER MUMBAI

No. DMC./ Infra / 1315 Dtd. 25-6-2021

Circular

Subject: Guidelines for use of Robohole (Manhole) frames, covers and gratings fixed on roads, footpath, drain covering slabs, water tanks etc. in MCGM works.

- Reference:**
1. Ch.Eng./740/Dir dtd. 20.08.2019
 2. Dir./E.S.&P./750/MC dtd. 08.08.2019
 3. MGC/F/9865 dtd. 05.08.2019.
 4. Ch.Eng/3964/SWD dtd. 18-09-2019.
 5. AMC/P/2147 Dtd. 21-06-2021.

Reference is requested to earlier circular regarding the same subject matter issued vide Sr. No. 4 cited above. Now, in view of recent incidents of citizen drowning in the open robo-hole (man-hole), these guidelines are issued for stricter compliance, with the approval of A.M.C.(P) vide (5) mentioned above.

Guidelines for use Robohole (Manhole) frames, covers and gratings fixed on roads roads, footpath, drain covering slabs, water tanks etc.

1. Use of F.R.P. Robohole (Manhole) frame and covers, gratings shall be strictly discontinued and condition to that effect shall be added by all departments in the standard bid documents for all future tenders.
2. The F.R.P. Robohole (Manhole) frames, covers and gratings items shall be discontinued for the ongoing works also and shall be deleted from Unified Schedule of rates forthwith.
3. The proposals of New registration of vendor for F.R.P. Robohole (Manhole) frame and covers, gratings shall be rejected. The existing registrations of vendor shall not be renewed.
4. To use Ductile Iron and Cast Iron frames & covers & M.S. /D.I. gratings as an alternative to F.R.P. frames, covers & gratings.

Sd/-

D.M.C. (Infrastructure)

Copy to:

Dir.(E.S.&P.), DMC(E), DMC(SE), DMC(Env.), DMC(SWM), DMC Zone : I / II / III / IV / V / VI /VII,

Copy to:

C.E., Ch.E.(Vig.), Ch.E.(D.P.), Ch.E. (CTI &RC), Ch.E. (Rds. & Traffic), Ch.E. (M&E), Ch.E. (SWD), H.E., Ch.E.(WSP), Ch.E.(C.S.), Ch.E.(S.O.), Ch.E.(S.P.), Ch.E.(B.M) City / Sub., Dy. C.E.(BC)City / ES / WS, Dy.C.E.(Bridges), Dy.M.A. I / II / III / IV, Dy.Ch.E.(DP)-I / II, Dy. Ch.E. (B.P.) Z-I / II, Dy. Ch.E. (CTI &RC), Dy. Ch.E. (Rds.) City, / ES / WS, Dy. Ch.E.(Traffic), Dy. Ch.E.(M&E) City / Subs. Dy. Ch.E.(SWD) City / ES/ WS, Dy. Ch.E.(O&M) SWD, Dy. H.E. WS / ES ./ Const. I / Maint / Bhandup Complex / Operations / Pise Panjrapur Complex / P&C, Dy.Ch.E.(WSP) CC / P&D / C-I / C-II / M&E, Dy.Ch.E.(CS) SP-I, Dy.Ch.E. (M&E) CS, Dy.Ch.E.(SO) City / ES/ WS / P&C, Dy.Ch.E.(SP) P&D / Construction, Dy.Ch.E.(M&E) SP, Dy.Ch.E. (PPCC), Dy.EE (M&R), EE(DP), EE(CTI & RC), EE(Roads) City / ES / WS, EE(T&C).

Assistant Commissioner : A,B,C,D,E, F/North, F/South, G/North, G/South, H/East, H/West, K/East, K/West, P/North, P/South, R/North, R/Central, R/South, L, M/East, M/West, N,S,T, BYL Nair Hospital, KEM Hospital, LTMG Hospital, Markets, Estate.

H.C. (S.W.D.)

Copy To:

The Secretary, The Municipal Construction Contractors Associates, 7, Prospect House, 29 Raghunath Dadaji Street, Fort, Mumbai-1.

Copy To:

The Secretary, Builders Association of India, G/1, Commerce Centre, 7th Floor, 78, Dadaji Street, Tardeo, Mumbai-34.

CIRCULAR

Subject:- Use of Quick Setting Cement (QSC) for Concrete Road Works.

Reference:- Discussion held with Hon'ble M.C. on 07.01.2016.

This has a reference to discussion held with Hon'ble M.C. on 07.01.2016 regarding concrete road works undertaken by Road Department.

During discussion, Hon'ble M.C. directed to use Quick Setting Concrete(QSC) henceforth for all cement concrete road works undertaken by Road Department. The use of QSC will reduce the curing period for concrete road works and newly constructed cement concrete roads can be opened to traffic much earlier to enable to give early service

Hence, item of Quick Setting Concrete (QSC) shall be included in further tender works adhering to its specifications.

(Signature)
Chief Engineer (Roads & Traffic)

DyChE(Roads)City

DyChE(Roads) ES

DyChE(Roads) WS

DyChE(Roads) Planning

DyChE(Roads)Traffic

A.E.(Asphalt)

14628

To Pds
circulate to all A/E/EA
ln

EE (Rds) ES (L & M/E)

09/02

(Signature)
प्रमुख अभि. (रस्ते) पु.उ.
21/2

⑦

MUNICIPAL CORPORATION OF GREATER MUMBAI

No. Dir / ES & P / -15 / 117 dated 31/12/19

MINUTES OF MEETING HELD ON 21-12-2019 AT 5.00 P.M. UNDER THE CHAIRMANSHIP OF DIRECTOR (E.S. & P.) REGARDING ACCIDENT COMPENSATION POLICY

The following officers were present for the meeting.

- | | | | |
|----|-------------------------|---|--------------------------|
| 1) | Shri Prakash Savardekar | - | Dy.Ch.Eng. (Roads) Plg. |
| 2) | Shri Ramdas Avhad | - | C.A. (W.S.S.D.) |
| 3) | Shri C.P. Metkar | - | E.E. (Const.) E.S., H.E. |
| 3) | Shri Sunil Jadhav | - | Dy.C.A. (Exp.), C.A. (F) |

The condition to be included in all civil works tenders having value more than Rs. 5 crores is discussed based on the draft policy prepared by Ch.Eng. (S.P.).

After the discussion, the draft is amended and the cases covered as mentioned in the draft policy which includes first aid, hospitalisation, partial/permanent disability and death.

To decide the cases for compensation, it is felt that a panel shall be formed comprising of

- i) HoD of the concerned deptt.
- ii) MOH of the Ward
- iii) A.S.O. of the Ward

or as may be decided by A.M.C. (P) / Hon'ble M.C.

The meeting then concluded.

[Signature]
Dir (ES & P)

Copy to:- H.E. / Ch.E.(S.P.) / ~~Ch.Eng. (Roads & Traffic)~~ / Ch.Eng. (S.O.) / Ch.Eng. (S.W.D.) / C.A. (F) / C.A. (W.S.S.D.)

मुंबई महानगरपालिका
प्रमुख अधिकारी (रस्ते वाहतूक)
कोरोना कार्यालय
- 6 JAN 2020
7004 / *[Signature]*
अ.प्र.अ. (रस्ते)

Dy. Ch. E. (Rds) City / W.S.E.S. / Traffic Planning, *[Signature]* (Asphalt Amt) (ESP)
For necessary action pls

[Signature]
18/1/20
E.E. (P) to
Ch. Eng. (Roads & Traffic)

21 JAN 2020

बृहन्मुंबई महानगरपालिका
उप प्रमुख अभियंता
(रस्ते) शहर यांचे कार्यालय, व्हॅट रोड,
(24)
दि. 28 JAN 2020
दि. 11, 12, 13, 14, 15, 16, 17
क्रमांक उप
श. शि. 9618 रस्ते
(शहर)

EX. ENG (RDS) - TY I/II/III/IV
A.O. (RDS) CITY/HC (EXP)/HC (ESTT)
FOR NECESSARY ACTION

H. G.
28/1/2020
DY. CH. ENG. (RDS) CITY.

pl.
includes
the same
in second
hand &
in all necessary
papers.

SPECIAL DIRECTIONS FOR ACCIDENT COMPENSATION

(To be included in tender conditions)

(A) Preamble:-

In MCGM infrastructural project works are ongoing by various departments such as Roads/SWD/IE/WSP/MSDP/Bridges/SO/SP/BM etc. As per GCC clause 12, 15 & Special Condition of Contract clause 53 at present contractor is submitting 3 policies namely,

1. W C Policy - Workmen Compensation Policy
2. CAR Policy - Contractor All Risk Policy
3. Maharashtra state worker Welfare Policy.

Workmen Compensation Policy covers for labours working on particular project as per Workman Compensation Act.

CAR Policy i.e. Contractor All Risk Policy covers contractor's work, plant, machinery etc and third party liability to the extent of one event.

Maharashtra State Worker Welfare Board's policy for welfare of workers.

In spite of observing all safety precautions at site, unforeseen incidences/ accidents/ untoward incident may happen. Further, it is observed that, Accidental Compensation to any third party / Public / Trespasser is not fully covered under any of these policies. In view of the various incidences / accidents occurring at site, it is felt that an Accident Compensation Policy to cater for public liability is necessary.

(B) Post accidental situation can be described in 4 stages:

1. In case of any mishap caused to any third person within construction site/ project site because of the negligence / or due to accident/ or untoward incident/ or due to unforeseen reason on account of contractors personnel / machinery resulting in to injury/ permanent disability / death, the contractor shall pay the following compensation to the citizen or his/her legal heir:

- a) **First Aid:** This facility shall be made available at each site by the contractor with all preliminary medical aid.
- b) **Hospitalization:** In case of injury, the contractor shall admit the injured person to the nearest Government hospital or in absence of Government /Municipal hospitals, Private hospital and shall bear all the medical expenses maximum up to Rs.20,000/-.

c) Partial/ Permanent Disability:

- i) In case of partial disability, compensation up to Rs.2,50,000/- shall be paid by the contractor within 7 days on receipt of directions from the competent authority/MCGM Pannel.
- ii) In case of permanent disability compensation up to Rs.5,00,000/- shall be paid by the contractor within 7 days on receipt of directions from the competent authority/ MCGM Pannel.

Note: The state of the partial/ permanent disability to the injured person will be decided after evaluation and certification from the MCGM Pannel.

d) Death:

In case of death, a fixed compensation of Rs.10,00,000/- shall be paid by the contractor to his/her legal heir within 15 days on receipt of directions from the competent authority/MCGM Pannel.

Contractor's obligation period will start from the date of issuance of the work order up to the date of completion of work on site.

Death/ Permanent Disability/ Partial Disability due to accident should not be caused by the following:

- a) Attempted suicide or self-inflicted injuries while sane or insane, or whilst the person is under the influence of any narcotic substance or drug or intoxicating liquor.
- b) The Death/ Permanent Disability/ Partial Disability shall be caused by violent, external and visible means.

MCGM Pannel :- May be included with

- 1) HOD of the concerned department
- 2) MOH of the Ward
- 3) A.S.O. of the Ward

Or as may be decided by the Municipal Commissioner.

MUNICIPAL CORPORATION OF GREATER MUMBAI

क्र. प्र. अ./637/SR/ रस्ते बाह. 10 FEB 2020

CIRCULAR

Sub:- Punitive charges / heavy fines to be levied on External Utility Agencies and trench RI contractor where:-

- 1) debris due to trenching activities is not picked up regularly causing obstruction to traffic and pedestrian movement
- 2) reinstatement of trenches is not done properly.

- Ref:-
- 1) Trench Policy Guidelines issued u/no. AMC/ES/7725/II dated 18/12/2014.
 - 2) Instructions given by Hon'ble MC vide no. MGC/A/1820 dated 10/01/2020.

By directions of Hon'ble MC following guidelines in respect of trenching activity are issued in addition to the prevailing Guidelines for Trenching Activity-2015 issued u/no. AMC/ES/7725/II dated 18/12/2014.

- 1) In cases where the work of reinstatement of trenches taken by utility agencies is found not done properly by the concerned trench RI contractor as per the specifications and above mentioned guidelines, Ward Exe. Engineer (WEE) of respective ward shall instruct the concerned RI contractor to rectify / redo the defective work as per the specifications and prevailing trench activity guidelines, within suitable time period. The concerned trench RI contractor shall rectify /redo the defective trench RI work within stipulated time period and up to the satisfaction of Ward Executive Engineer. Further, penalty of Rs.50,000/- shall be imposed on the concerned Trench RI contractor for the said initial lapse. If the said trench RI contractor fails to rectify / redo the defective work within stipulated time and up to the satisfaction of WEE of respective ward, additional penalty of Rs 50,000/- per day shall be imposed on the said Trench RI contractor till compliance.
- 2)(i) During progress of trenching activity, trenches shall be properly barricaded by the External Utility Agencies as per prevailing / applicable circular. Further, Debris / surplus excavated material shall be stacked properly beside the trench and within barricaded area so as to avoid obstruction to traffic and pedestrian movement. The said debris / surplus excavated material shall be completely removed from the site immediately after completion of the trenching activity by removing the barricades. In case of failure penalty of Rs.50,000/- per day shall be imposed on the concerned External Utility Agency till compliance.
- (ii) During progress of trench RI work, trenches shall be properly barricaded by the trench RI contractors as per prevailing / applicable circular. Further, Debris / surplus excavated material shall be stacked properly beside the trench and within barricaded area so as to avoid obstruction to traffic and pedestrian movement. The said debris/surplus excavated material shall be completely removed from the site immediately after completion of the trench RI work by removing barricades. In case of failure penalty of Rs.50,000/- per day shall be imposed on the concerned trench RI contractor till compliance.

All head of the departments and Asstt. Commissioner and WEE of respective ward offices shall take note of this circular and ensure that the same is followed scrupulously.

This circular will come in force with immediate effect.

sd/-
15/01/2020
DMC(Infrastructure)

sd/-
15/01/2020
AMC(ES)

Copy to:

Asstt. Commissioner (A, B, C, D, E, F/South, F/North, G/South, G/North, H/East, H/West, K/East, K/West, L, M/East, M/West, N, P/South, P/North, R/South, R/Central, R/North, S, T) Ward / City Engineer/Ch.Eng.(Bridges)/Ch.Eng.(WSP)/H.E./ Ch.Eng.(S.P.)/Ch.Eng.(MSDP)/Ch.Eng.(BM)/Ch.Eng.(Vig)/Ch.Eng.(M.&E.)/Ch.Eng.(DP)/Ch.Eng.(SWD)/Ch.Eng.(SWM)/Ch.Eng.(CTIRC)/Ch.Eng.(CoastalRoads)/Dy. Ch.Eng.(HIC)/Dy.Ch.Eng.(SIC)/Supr. of Gardens.

Forwarded for information and necessary action in the matter with immediate effect please.

Ch.Eng. (Roads & Traffic)

MUNICIPAL CORPORATION OF GREATER MUMBAI

(Roads & Traffic Department)

No. Ch.E. /Roads & Tr./ 390 Dt. 22.10.2021

Subject:- Common Corrigendum regarding A.S.D. condition modifications in Road works tenders in City, E.S and W.S Divisions.

Reference is requested to the e-Tender Notices Published under work code numbers : E-265, E-266, E-272, E-268, E-267, AE-133, E-271, E-277, E-278, E-279, E-269, W-361, AW-207, AW-218, W-362, W-370, W-374, AW-205, AW-204, AW-222, W-364, W-375, W-377, W-367, W-382, AC-171, AC-172, C-274, C-275, C - 287, C-292, C-282, C-288, C-289, C-281, C-285, C-283, C-286, C-276, C-280, AW-225, AW-197, AW-226, AW-227, W-381, AW-224, E-282, C-291, E-283, E-284, E-285, W-400, W-366, W-387 and W-379.

A Common Corrigendum is issued herewith to inform the bidders regarding ASD condition modifications for the above mentioned Road work tenders in City, E.S and W.S Divisions. The condition of submitting A.S.D. is partially modified as under:

“All the bidders are directed to submit the A.S.D. as applicable in the form of Demand Draft, which is to be submitted within office hours one day before opening of ‘Packet C’ to respective Head Clerk (Expenditure) of road division in sealed envelope. If A.S.D. is not applicable then the bidders shall submit sealed envelope mentioning on their letter heads ‘ASD is not applicable’.

If the bidders fails to submit the sealed envelope as mentioned above at least one day before opening of ‘Packet C’ within office hours then the E.M.D. of the respective bidders will be forfeited and the company with their Directors / Partners and other companies with the said Directors / Partners will be further debarred from any tendering process for the period of at least 2 years.”

All bidders are requested to take note of above modifications.

Sd/-
22.10.2021
Ch. Eng. (Roads & Traffic)

MUNICIPAL CORPORATION OF GREATER MUMBAI

Ch. Eng / 400/ SR /Roads & Traffic of 02/11/2021

Modifications to ChE(Vigilance) department related conditions for (Stage-I, II and III Tenders)

- Sub.:**
1. E-Tenders for work codes E-265, E-266, E-272, E-268, E-267, AE-133, E-271, E-277, E-278, E-279, E-269, W-361, AW-207, AW-218, W-362, W-370, W-374, AW-205, AW-204, AW-222, W-364, W-375, W-377, W-367, W-382, AC-171, AC-172, C-274, C-275 from the department of Chief Engineer (Roads & Tr.)
 2. E-Tenders for work codes C -287, C-292, C-282, C-288, C-289, C-281, C-285, C-283, C-286, C-276, C-280, AW-225, AW-197, AW-226, AW-227, W-381, AW-224 and E-282 from the department of Chief Engineer (Roads & Tr.)
 3. E-Tenders for work codes C-291, E-283, E-284, E-285, W-400, W-366, W-387 and W-379 from the department of Chief Engineer (Roads & Tr.)
- Ref.:** Vigilance department note u./no. ChE/Vig/89/Conf. dated 22.10.2021 approved by Hon. MC u./no. MGC/F/5524 dated 02.11.2021.

ChE(Vigilance) department has submitted a note proposing changes in the Tender conditions related to role of Vigilance department in Roads department tenders. The said note is approved by Hon. M.C u./no. MGC/F/5524 dated 02.11.2021. Hence it is necessary to issue corrigendum in all Stage-I,II and III tenders and to include the modification in proposed Thermoplastic painting tenders and tenders to be invited henceforth as under:-

Sr No	Relevant Clause	Prevailing tender Condition (as amended by Prebid Minutes of Meeting)	Proposed Modified Tender Condition.
1	2.6.(5) of Section 2 - Eligibility Criteria-	The failure in providing experienced technical and /professional ability personnel and even ignoring the instruction of the Engineer-in-charge shall be linked to penalization. Such disobeying attitude of the contractor shall also be reported to Vigilance/Registration & Monitoring department.	The failure in providing experienced technical and /professional ability personnel and even ignoring the instruction of the Engineer-in-charge shall be linked to penalization. Such disobeying attitude of the contractor shall also be reported to Registration & Monitoring department as per rules governing Registration of Contractors for Civil and Mechanical & Electrical Engineering works-2016.
2	6.13(4) of Instructions to Applicants	Directions will be issued to Vigilance department for carrying out compulsory monthly frequent visits to RMC/Asphalt/Mastic plants/Batch mix plant, Material sources and road sites. The bidder/contractor and plant owner(s) shall extend full cooperation to the vigilance department staff during such visits.	The Vigilance department will carry out the random site inspections of road work as per the prevailing guidelines and modalities of Vigilance department issued u./no. ChE/Vig 3170/B dated 21.09.2016 and ChE/Vig/1490/B dated 02.08.2018.

In view of the above, Ch.E. (Roads & Traffic)'s approval is requested to:

1. the Corrigendum pertaining to changes in conditions related to ChE(Vigilance department).
2. To incorporate the condition in proposed Thermoplastic painting tenders and future tenders.

3. Publishing this corrigendum on portal and uploading in SRM System.

Submitted for approval please.

Shri Manoj Kamat
Dy.Ch.E. (Roads) W.S.

Shri Chandrakant Metkar
Dy.Ch.E.(Roads) E.S.

Shri Ashok Mestry
Dy.Ch.E.(Roads) City

Shri Rajendra Talkar
Ch.E. (Roads & Traffic) / DMC (Infra.)

MUNICIPAL CORPORATION OF GREATER MUMBAI

Ch. Eng / 400/ SR /Roads & Traffic of 02/11/2021

Modifications to ChE(Vigilance) department related conditions for (Stage-I, II and III Tenders)

- Sub.:**
1. E-Tenders for work codes E-265, E-266, E-272, E-268, E-267, AE-133, E-271, E-277, E-278, E-279, E-269, W-361, AW-207, AW-218, W-362, W-370, W-374, AW-205, AW-204, AW-222, W-364, W-375, W-377, W-367, W-382, AC-171, AC-172, C-274, C-275 from the department of Chief Engineer (Roads & Tr.)
 2. E-Tenders for work codes C -287, C-292, C-282, C-288, C-289, C-281, C-285, C-283, C-286, C-276, C-280, AW-225, AW-197, AW-226, AW-227, W-381, AW-224 and E-282 from the department of Chief Engineer (Roads & Tr.)
 3. E-Tenders for work codes C-291, E-283, E-284, E-285, W-400, W-366, W-387 and W-379 from the department of Chief Engineer (Roads & Tr.)

Ref.: MGC/F/5524 dated 02.11.2021.

Sr No	Relevant Clause	Prevailing tender Condition (as amended by Prebid Minutes of Meeting)	Modified Tender Condition.
1	2.6.(5) of Section 2 - Eligibility Criteria-	The failure in providing experienced technical and /professional ability personnel and even ignoring the instruction of the Engineer-in-charge shall be linked to penalization. Such disobeying attitude of the contractor shall also be reported to Vigilance/Registration & Monitoring department.	The failure in providing experienced technical and /professional ability personnel and even ignoring the instruction of the Engineer-in-charge shall be linked to penalization. Such disobeying attitude of the contractor shall also be reported to Registration & Monitoring department as per rules governing Registration of Contractors for Civil and Mechanical & Electrical Engineering works-2016.

2	6.13(4) of Instructions to Applicants	Directions will be issued to Vigilance department for carrying out compulsory monthly frequent visits to RMC/Asphalt/Mastic plants/Batch mix plant, Material sources and road sites. The bidder/contractor and plant owner(s) shall extend full cooperation to the vigilance department staff during such visits.	The Vigilance department will carry out the random site inspections of road work as per the prevailing guidelines and modalities of Vigilance department issued u./no. ChE/Vig 3170/B dated 21.09.2016 and ChE/Vig/1490/B dated 02.08.2018.

Sd/- 02.11.2021
Shri Rajendra Talkar
Ch.E. (Roads & Traffic) / DMC (Infra.)

MUNICIPAL CORPORATION OF GREATER MUMBAI

Central Purchase Department

CIRCULAR

No. D.M.C./CPD/3217 Date: 02.03.2019

Sub : To incorporate new clause of internal "GRIEVANCE REDRESSAL MECHANISM" in the standard Bid document.

Ref: i) CA/FRD/I/05 dt. 10.05.2016
ii) MGC/F/8155 dtd. 30.01.2019.

- Vide above reference, Hon'ble M.C. has granted to discontinue the existing Procurement Redressal Committee & to incorporate new clause of internal "GRIEVANCE REDRESSAL MECHANISM" as mentioned below in the bid document.

INTERNAL GRIEVANCE REDRESSAL MECHANISM

M.C.G.M. has formed a internal Grievance Redressal Mechanism for redressal of bidder's grievances. Any Bidder or prospective Bidder aggrieved by any decision, action or omission of the procuring entity being contrary to the provisions of the tender or any rules or guidelines issued therein, in Packet 'A', 'B' & 'C' can make an application for review of decision of responsiveness in Packet 'A', 'B' & 'C' within a period of 7 days or any such other period, as may be specified in the Bid document.

While making such an application to procuring entity for review, aggrieved bidders or prospective bidders shall clearly specify the ground or grounds in respect of which he feels aggrieved.

Provided that after declaration of a bidder as a successful in Packet 'A' (General Requirements), an application for review may be filed only by a bidder who has participated in procurement proceedings and after declaration of successful bidder in Packet 'B' (Technical Bid), an application for review may be filed only by successful bidders of Packet 'A'. Provided further that, an application for review of the financial bid can be submitted, by the bidder whose technical bid is found to be acceptable / responsive.

Upon receipt of such application for review, M.C.G.M. may decide whether the bid process is required to be suspended pending disposal of such review. The M.C.G.M. after examining the application and the documents available to him, give such reliefs as

may be considered appropriate and communicate its decision to the Applicant and i
required to other bidders or prospective bidders, as the case may be.

M.C.G.M. shall deal and dispose off such application as expeditiously as possible
and in any case within 10 days from the date of receipt of such application or such other
period as may be specified in pre-qualification document, bidder registration document
or bid documents, as the case may be.

Where M.C.G.M. fails to dispose off the application within the specified period or if
the bidder or prospective bidder feels aggrieved by the decision of the procuring entity,
such bidder or prospective bidder may file an application for redressal before the
'Internal Procurement Redressal Committee' within 7 days of the expiry of the allowed
time or of the date of receipt of the decision, as the case may be. Every such
application for internal redressal before Redressal Committee shall be accompanied by
fee of Rs.25,000/- and fee shall be paid in the form of D.D. in favour of M.C.G.M.

**1st Appeal by the bidder against the decision of C.E./HoD/Dean can be
made to concerned D.M.C /Director who should decide appeal in 7 days.**

**If not satisfied, 2nd Appeal by the bidder can be made to concerned A.M.C
for decision.**

Grievance Redressal Committee (GRC) is headed by concerned D.M.C / Director
of particular department for the first appeal / grievances by the bidder against the
decision for responsiveness / non-responsiveness in Packet 'A', Packet 'B' or Packet 'C',
and if not satisfied, concerned A.M.C. will take decision as per second appeal made by
the bidder.

This Grievance Redressal Committee (GRC) will be operated through
DMC(CPD) office where appeals of aggrieved bidder will be received with fee of
Rs. 25,000/- from aggrieved bidder. The necessary correspondence in respect
of said applications to the aggrieved bidder & concerned department, issuing
notices, arranging of Grievance Redressal Committee (GRC) with D.M.C and
further proceeding will be carried out through registrar appointed by MCGM.

No application shall be maintainable before the redressal Committee in regard of
any decision of the M.C.G.M. relating to following issues:

- Determination of need of procurement
- The decision of whether or not to enter into negotiations.
- Cancellation of a procurement process for certain reasons.

On receipt of recommendation of the Committee, It will be communicated his
decision thereon to the Applicant within 10 days or such further time not exceeding 20
days, as may be considered necessary from the date of receipt of the recommendation
and in case of non-acceptance of any recommendation, the reason of such non-
acceptance shall also be mentioned in such communication.

Additional Municipal Commissioner and/or Grievance Redressal Committee, if found, come to the conclusion that any such complaint or review is of vexatious, frivolous or malicious nature and submitted with the intention of delaying or defeating any procurement or causing loss to the procuring entity or any other bidder, then such complainant shall be punished with fine, which may extend to Five Lac rupees or two percent of the value of the procurement, whichever is higher.

- All head of department are therefore requested to take a note of above and process tenders accordingly.

Sd/- 21.02.19

D.M.C(CPD)

CIRCULAR

2018-19

No. D.M.C./CPD/3217 Date: 02.03.2019

CC: to

Director(E.S&P)	D.M.C(E)	D.M.C(S.E)	D.M.C(SWM)	D.M.C(Education)
D.M.C(Vig.)	D.M.C(Z-I)	D.M.C(Z-II)	D.M.C(Z-III)	D.M.C(Z-IV)
D.M.C(Z-V)	D.M.C(Z-VI)	D.M.C(Z-VII)	D.M.C(A&C)	D.M.C(Improvement)
D.M.C(D.M)	D.M.C(Spl.)	D.M.C(M.C's Office)	D.M.C(E.R.)	Director(M.E & M.H)
Ch.M.S(Sp. Hosp.)	E.H.O Dean (LTMG Hosp.& Med. College)	P.S. to M.C. Dean (B.Y.L Nair Hosp.)	C.E. Dean (Nair Hosp. Dental College)	P.S. to AMC(P)/w/c/25/2019 H.E.
Dean (KEM Hosp.)				
Ch.E.(D.P)	Ch.E.(Roads & Traffic)	Ch.E.(M.S.D.P)	Ch.E.(SWD)	Ch.E.(S.O)
Ch.E.(S.P)	Ch.E.(W.S.P)	Ch.E.(Vig.)	Ch.E.(B.M)	Ch.E.(S.W.M)
Ch.E.(Bridge)	Ch.E.(M&E)	Ch.E.(C.T.I. & R.C)	Ch. L.O	Edu. Officer
M.A	Security Officer	Law Officer	Supt. Of Garden	Supt. Of Licence
M.C.A	M.S.	C.A.(F)	C.A.(T)	C.A.(W.S.S.D)

Copy submitted for information please

DY. CA (Exp)

21/02/19
DY.Ch.E.(CPD)

लेखा अधिकारी (उत्तर) 21/2

Scanned by CamScanner

Municipal Corporation of Greater Mumbai

(Solid Waste Management Department)

No. D.M.C./S.W.M./4677 dt: 12/02/2019.

Subject: - Implementation of the Construction & Demolition Waste Management Rules 2016

Reference: - i) Hon'ble Supreme Court's order in the Special Leave petition (civil) No. D 23708/2017, dated 15/03/2018
ii) Hon'ble M.C. Sir's Approval u/no. MGC/F/7076 dt. 30.08.2018
iii) Circular u/no. Dy.Ch.E/SWM/3957/OP. dt. 28/09/2018
iv) Monitoring Committee Meetings dt. 28/11/2018 & 23/01/2019
v) DMC / SWM / 3988 dt. 28/12/2018

A Circular has already been issued as per approval of Hon. M.C. sir regarding S.O.P. to be followed for implementation of the Construction & Demolition Waste Management Rules 2016 which mandates all departments to obtain approval to C & D Waste Management Plan from SWM Department for proper disposal of C & D waste material generated out of works carried out by them.

This office has already issued a note to all Depts. / Wards offices to comply the directives and submit their monthly report in prescribe format before 5th of every month.

However, the response from the Departments / Wards is every poor and the Monitoring Committee has expressed its unhappiness for the same.

Director (E.S.& P.) / D.M.C.(S.E.) / D.M.C.(E.) / Zonal D.M.C. / D.M.C. (Education) are therefore requested to instruct concerned staff & A.Cs. / HODs to comply with the above requirements and submit the report in prescribed format and attached herewith by 5th of every month and submit the on email ec01z6.swm@mcgm.gov.in / dycheswmop@gmail.com

D.M.C. (S.W.M.)

Director (E.S.& P.) / D.M.C.(S.E.) / D.M.C.(E.)

D.M.C.(Z-) / D.M.C. (Education)

T to VII

Municipal Corporation of Greater Mumbai

(Solid Waste Management Department)

Subject: - Implementation of the Construction & Demolition Waste Management Rules 2016

Reference: - i) Circular u/no. Dy.Ch.E/SWM/3957/OP. dtd. 28/09/2018
ii) Directives of High Court appointed Monitoring Committee
iii) DMC/SWM/3998 dt. 28.12.2018

Details of S.W.M. NOCs obtained for departmental work by various MCGM departments
(To be emailed to ce01z6.swm@mcgm.gov.in / eeswmz6@gmail.com every month)

Name of the Department / Sub Division: _____

Month: _____

Sr. No.	Month	No. of S.W.M. NOCs Obtained by contractors	No. of Work Orders issued	Action taken / Proposed for non-compliance	Remarks
1.	Cumulative till previous month				
2.	This month _____				

Asstt. Engr. _____

Ex. Engr. _____

Dy. Ch.E.(S.W.M.)Op.

Municipal Corporation of Greater Mumbai

(Solid Waste Management Department)

No. D.M.C./S.W.M./ 3988#2 8 DEC 2018.

Subject: - Implementation of the Construction & Demolition Waste Management Rules 2016

Reference: - i) Hon'ble Supreme Court's order in the Special Leave petition (civil) No. D 23708/2017, dated 15/03/2018
ii) Hon'ble M.C. Sir's Approval u/no. MGC/F/7076 dt. 30.08.2018
iii) Circular u/no. Dy.Ch.E/SWM/3957/OP. dt. 28/09/2018
iv) Monitoring Committee Meeting dt. 28/11/2018

A Circular has already been issued regarding SOP to be followed for implementation of the Construction & Demolition Waste Management Rules 2016 which mandates all departments to obtain SWM C & D NOC for proper disposal of C & D waste material generated out of works carried out by them.

During the discussion in the monthly meeting held on 28/11/2018, the Monitoring Committee has called for compliance of the directives in the circular stating that the department has taken necessary action regarding obtaining SWM C & D waste management NOC for disposal of C & Waste material generated during departmental works.

All concerned departments are hereby requested to submit the relevant information in the attached format by 15th of every month positively on email- eeswmz6@gmail.com / ect126.swm@mcgm.gov.in as the same is required to be given to the Monitoring Committee every month.



D.M.C. (S.W.M.)

Municipal Corporation of Greater Mumbai

No. Dy.Ch.Eng./SWM/3957/Op. dt. /09/2018

CIRCULAR

28-9-2018

Subject: Implementation of the Construction and Demolition Waste Management Rules, 2016

Reference: i) Hon'ble Supreme Court's order in the Special Leave Petition (civil) No. D 23708/2017, dated 15/03/2018
ii) Hon'ble M.C. Sir's Approval u/no. MGC/F/7076 dtd. 30.08.2018

The Construction and Demolition Waste Management Rules, 2016 is applicable to 'every waste resulting from construction, re-modeling, repair and demolition of any civil structure of individual or organisation or authority who generates construction and demolition waste such as building materials, debris, rubble'.

Hon'ble Supreme Court vide order dated 15/03/2018, has directed to dispose of construction and demolition waste material by following due procedure in accordance with the provisions of the Construction and Demolition Waste Management Rules, 2016".

In order to put curb on the un-authorisedly dumped waste, it is essential to control it by asking ward Maintenance department or any MCGM department to issue work-permission only after assessing the total estimated quantity of C&D waste likely to be generated out of the repairs / construction / trenching work or any such civil works, and asking them to make payment in advance or in stages of waste generation for the 'Debris on Call' system or transport C&D waste to designated unloading site.

Following standard operating procedure is proposed to be adopted:

- 1) MCGM department like A. E. (Maintenance), A. E. (B&F), H.E., S.O., S.P., M.S.D.P., W.S.P., S.W.D., S.W.M., C.E., B.C., B.M., Roads, Bridges, etc. carrying out civil work / repairs works etc. shall put condition in the tender / quotation / work order to dispose of C&D waste generated either by (i) 'Debris on Call' scheme if generation of C&D waste is less than 300MT for entire project or (ii) contractor shall transport to designated unloading site approved by MCGM S.W.M. department by following due procedure if C&D waste is more than 300MT for entire project.
- 2) The estimated quantity of the C&D waste generated shall be certified by A.E. (Maintenance) Ward or the concerned department.
- 3) If quantity of C&D waste is less than 300MT, A. E. (S.W.M.) Ward will issue Challan for making payment as per 'Debris on call' scheme on approval from Zonal Ex. Eng. (S.W.M.).
- 4) If quantity of C&D waste is more than 300MT, the contractor / agency will submit C&D waste management plan complete with requisite documents to Zonal Ex. Eng. (S.W.M.). On approval, the contractor / citizen / agency carrying out the civil works will be allowed to transport the C&D waste material to the designated unloading site.
- 5) The contractor / citizen / agency carrying out the civil works shall maintain & submit the appropriate record like date, quantity of C&D waste transported, vehicle No., Challan of Receipt of C&D waste from unloading site etc.
- 6) The whole system of issuing NOC for C&D waste transportation and payment will be made ONLINE and for this M/S. Softtech will be asked to develop appropriate software on the basis of existing norms being done for auto-DCR portal.
- 7) The proposals will be processed manually till the complete system fully operational online.
- 8) All the contractors / agencies using designated unloading site must maintain proper record of the C&D waste generated and transported along with date and vehicles through which C&D is transported & the copies of Challans from unloading site for having unloaded the C&D waste and submit the same to A.E. (S.W.M.) ward through concerned department.

Sd/-07/08/2018
Ch. Eng. (S.W.M.)

Sd/-07/08/2018
D.M.C. (S.W.M.)

Sd/-10/08/2018
A.M.C.(E.S.)

Sd/-29/08/2018
Municipal Commissioner

Forwarded for information and compliance please

Dy. Ch. Eng. (SWM) Op.

MUNICIPAL CORPORATION OF GREATER MUMBAI

No. Dy.ChE /8696/SWD / WS - dtd ' 16 JUL 2020 ' N/1

Subject : To Standardize Storm Water Drains Cross sections in S.W.D. Department of MCGM

Ref : 1. DyChE/4017/SWD/WS dated 16.08.2019.
2. Report received from IIT, Bombay (u/no. No. DRD/CE/114278/19-20) dated 11.02.2020.

SWD Department undertakes various works such as Construction of SWD under footpath; box drains flush to road, culverts, carriageway entrances, etc to abate flooding. It was observed that while preparing estimates, there was non-uniformity in the cross sections and quantity of steel per cubic meter of concrete.

Due to non-uniformity of cross sections and higher grade of concrete adopted for miscellaneous structural sections, Vigilance department had raised objections to the same in past. Hence to avoid this and bring uniformity in the preparation of estimates within the department of SWD it was proposed to Standardize Storm water box drain cross-sections in S.W.D. department of MCGM. Accordingly, after approval from Director (ES&P) u/no. Dir/ES&P/344/IV dated 24.07.2019, the work was entrusted to IIT, Bombay for Design for the typical cross-sections of road side storm water box drains adopted in various conditions in MCGM.

Mean time as the report from IIT, Bombay was awaited and estimates were to prepared for proposed new works and to bring uniformity in the preparation of estimates within the department of SWD, various cross-sections and quantity of steel for respective cross-sections of drains under footpaths, culverts, drains flush to road were prepared and a common guidelines were issued after approval of Ch.E.(SWD) u/no. DyChE/4017/SWD/WS dated 16.08.2019. (at Pg C/ 1).

Now, IIT, Bombay has submitted the detailed report vide ref.no. 2, along with detail design calculations with cross-sectional details, grade of concrete, steel and drawings with reinforcement details to be adopted for various water way widths of box type SWD . Copy of the same is attached herewith at Page C/ 3 to C/ 27.

As per the report submitted by IIT, Bombay, they have informed the

N/2

details of cross-sections of raft, wall and top slab along with details of reinforcement and grade of concrete and steel for various water way width (from 0.60 m to 2.5 m) of box type SWD. Hence, a comparative statement for various SWD cross-sections (from 0.60 m to 2.5m waterway widths) and respective reinforcement reported by IIT, Bombay and the common guidelines of Chief Engineer (SWD) dated 16.08.2019 was prepared. The copy of the same attached herewith at Pg C/39 . As per the comparative statement, the reinforcement proposed by IIT, Bombay found to be economical from cost point of view.

In view of above, Ch.E.(S.W.D.)/D.M.C.(Infra)'s approval is requested for the following :-

- a) To accept the detail report submitted by IIT, Bombay dated 11.02.2020 mentioning the details of Cross-sections for typical SWD, grade of concrete and steel along with reinforcement to be utilized for construction of box type road side SWD (for various water way widths from 0.60 m to 2.5 m) (copy from Pg-C/3 to C/37) for construction of Roadside Storm water box drains in various conditions in M.C.G.M.
- b) On receipt of approval, the design submitted by IIT, Bombay dated 11.02.2020 shall be adopted henceforth for preparation of estimates for the proposed new works in SWD department.
- c) On approval, the design and drawing details received from IIT, Bombay shall be informed to various Wards and Central Agencies of MCGM to maintain the uniformity in preparation of estimates and construction of box type Roadside Storm water box drains to be adopted in various conditions in M.C.G.M.

Submitted please

11.11.12 16/7
Dy.Ch.E.(S.W.D.)W.S.

~~Ch.E.(S.W.D.)~~
Sir,

~~D.M.C.(Infra)~~
Sir,

[Signature]
20/11/20
Chief Engineer i/c
Storm Water Drains

As proposed
[Signature]
21.9.2020

ChE-SWD

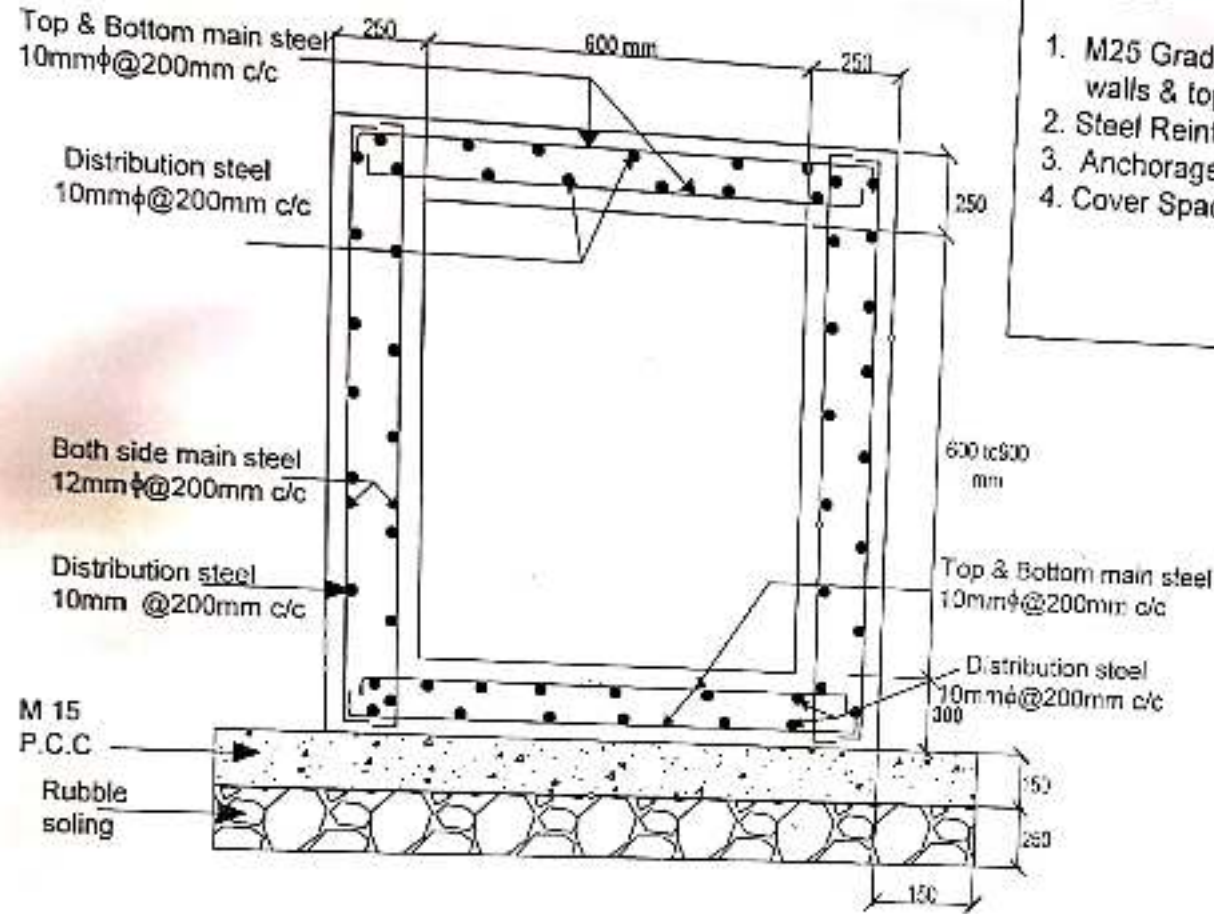

- NOTES:**
1. M25 Grade of concrete shall be used for raft, side walls & top slab.
 2. Steel Reinforcement of Grade FE500/FE500D to be used.
 3. Anchorage length for all main reinf. 200mm.
 4. Cover Space = 40 mm.
- All Dimensions in mm.
Not to Scale.

CASE 1 :- CLEAR WATER WAY WIDTH 600 MM

Dr.
11/2/2020
डॉ. जयदीप्ता घोष / Dr. Jayadipta Ghosh
 सहायक प्राध्यापक - Assistant Professor
 सिविल अभियांत्रिकी विभाग
 Department of Civil Engineering
 भारतीय प्रौद्योगिकी संस्थान मुंबई
 Indian Institute of Technology Bombay
 पवई / Powai मुंबई / Mumbai - 400 076 INDIA

TYPICAL C/S FOR ROADSIDE SWD FOR PEDESTRIAN TRAFFIC
(Below FOOTPATH)

Dr.
 11/2/2020
DY. CH. E. (S.W.D.) W&S. | *Dr.*
 11/2/2020
DY. CH. E. (S.W.D.) E.S. | *Dr.*
 11/2/2020
DY. CH. E. (S.W.D.) CITY. | *Dr.*
 11/2/2020
CH. ENG. (S.W.D.) | *Dr.*
 11/2/2020
D.M.C. (INFRA)

PRODUCED BY AN AUTODESK EDUCATIONAL PRODUCT

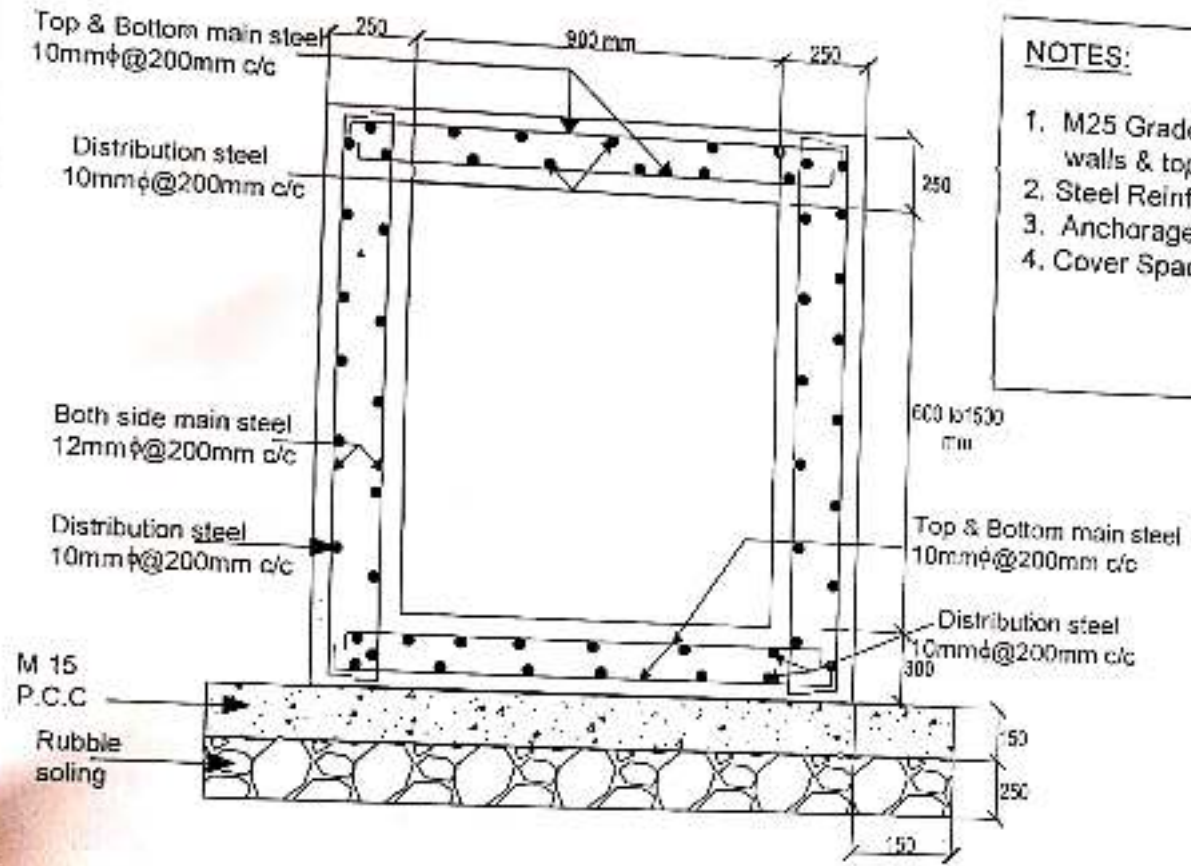

NOTES:

1. M25 Grade of concrete shall be used for raft, side walls & top slab.
2. Steel Reinforcement of Grade FE500/FE500D to be used.
3. Anchorage length for all main reinf. 200mm
4. Cover Space = 40 mm.

All Dimensions in mm
Not to Scale.

[Signature] 11/4/2020

Dr. Jayadipta Ghosh
 सहायक प्राध्यापक-Assistant Professor
 सिविल अभियंत्रिकी विभाग
 Department of Civil Engineering
 भारतीय प्रौद्योगिकी संस्थान मुंबई
 Indian Institute of Technology Bombay
 पवई/Powal मुंबई/Mumbai-400 075 INDIA

CASE 2 :- CLEAR WATER WAY WIDTH 900 MM

TYPICAL C/S FOR ROADSIDE SWD FOR PEDESTRIAN TRAFFIC (Below FOOTPATH)

<p><i>[Signature]</i> DY. CH. E. (S.W.D) W.S.</p>	<p><i>[Signature]</i> DY. CH. E. (S.W.D) E.S.</p>	<p><i>[Signature]</i> DY. CH. E. (S.W.D) CITY.</p>	<p><i>[Signature]</i> CH. ENG. (S.W.D)</p>	<p><i>[Signature]</i> D.M.C. (INFR)</p>
--	--	---	---	--

1/03

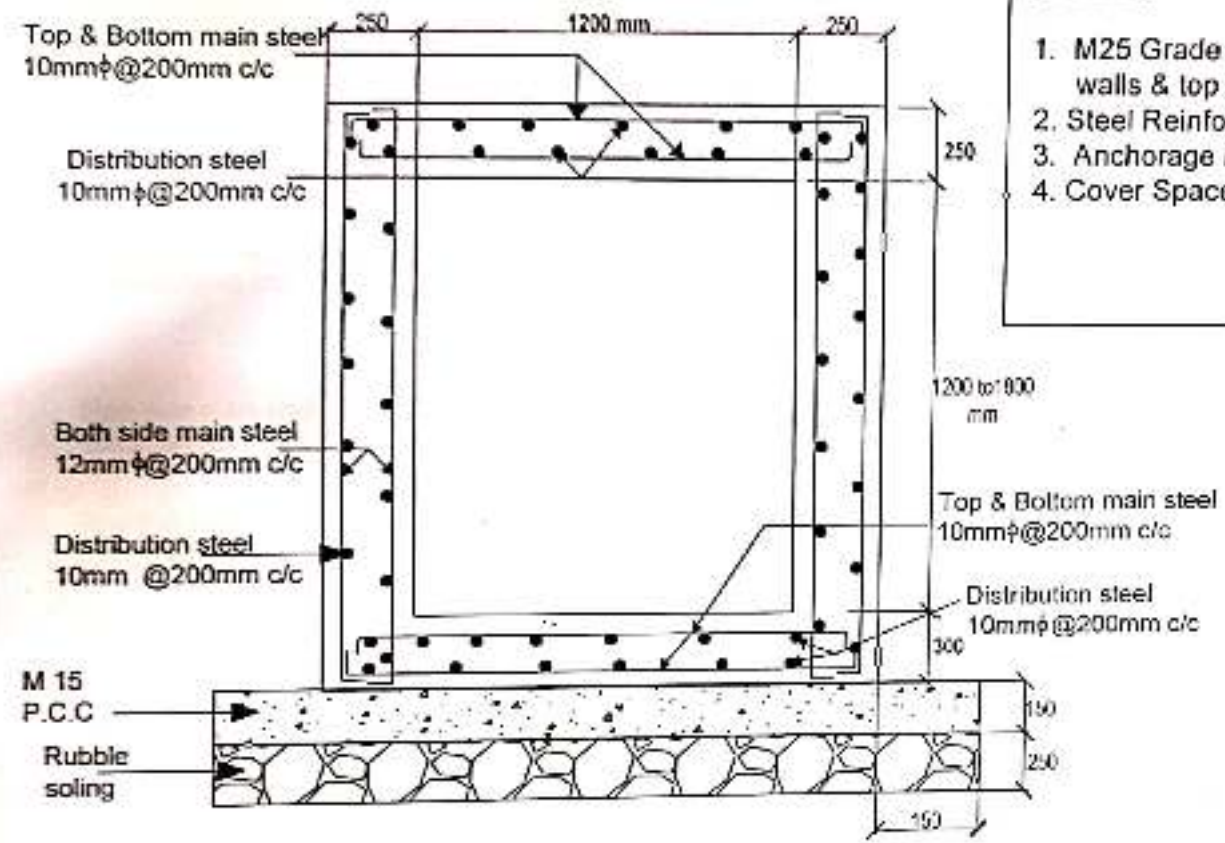

CASE 3 :- CLEAR WATER WAY WIDTH 1200 MM

NOTES:

1. M25 Grade of concrete shall be used for raft, side walls & top slab.
2. Steel Reinforcement of Grade FE500/FE500D to be used.
3. Anchorage length for all main reinf. 200mm
4. Cover Space = 40 mm.

All Dimensions in mm.
Not to Scale.

J.W. 11/02/2020

डॉ. जयदीप्ता घोष / Dr. Jayadipta Ghosh
 सहायक प्राध्यापक - Assistant Professor
 सिविल अभियंत्रिकी विभाग
 Department of Civil Engineering
 भारतीय प्रौद्योगिकी संस्थान मुंबई
 Indian Institute of Technology Bombay
 पवई / Powal मुंबई / Mumbai - 400 076 INDIA

TYPICAL C/S FOR ROADSIDE SWD FOR PEDESTRIAN TRAFFIC
 (Below FOOTPATH)

1/10/20
 DY. CH. E. (S.W.D) W.S. DY. CH. E. (S.W.D) E.S. DY. CH. E. (S.W.D) CITY. CH. ENG. (S.W.D) D.M.C. (INFRA)

PRODUCED BY AN AUTODESK EDUCATIONAL PRODUCT

Scanned with CamScanner

PRODUCED BY AN AUTODESK EDUCATIONAL PRODUCT

c/24

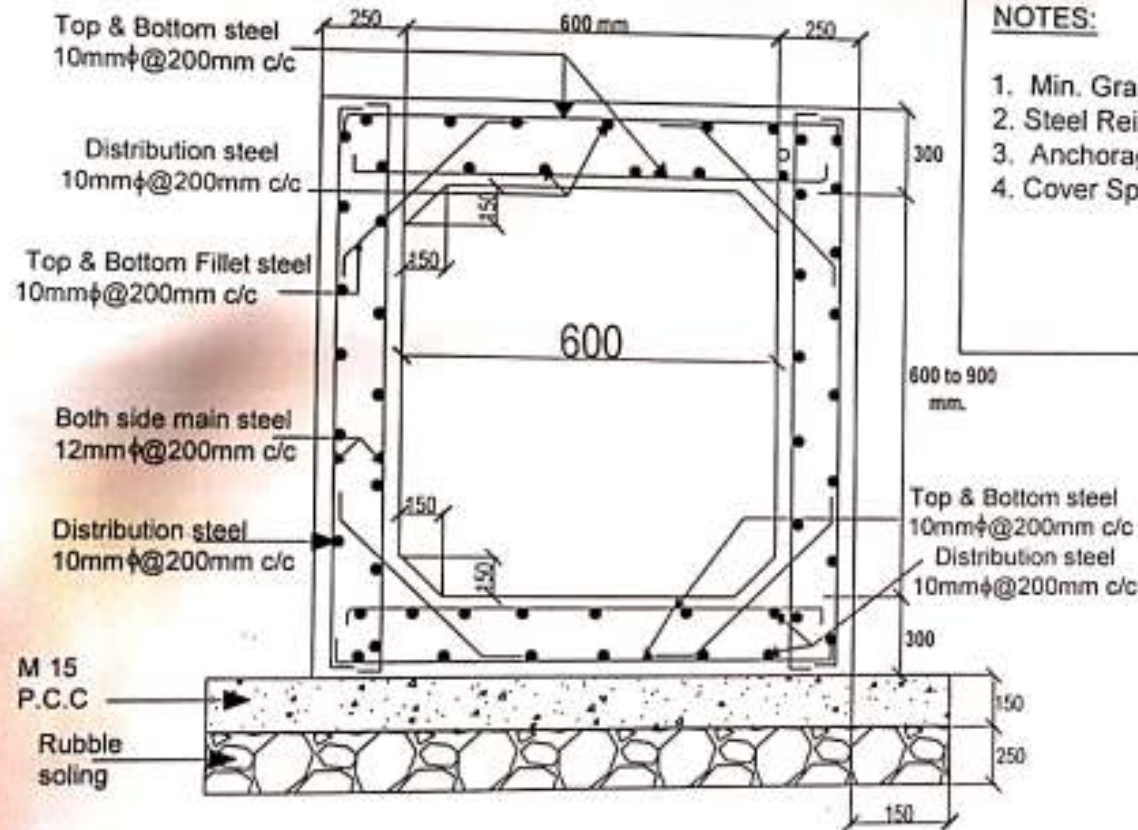

NOTES:

1. Min. Grade of Concrete = M-40.
2. Steel Reinforcement of Grade = Fe500 / Fe500D
3. Anchorage length for all Main Reinforcement = 250mm
4. Cover Space = 40 mm

All Dimensions in mm.
Not to Scale.

CASE 1 :- CLEAR WATER WAY WIDTH 600 MM

[Signature]

11/2/2020

डॉ. जयदीप्ता घोष / Dr. Jayadipta Ghosh
 सहायक प्राध्यापक - Assistant Professor
 विहित अभियांत्रिकी विभाग
 Department of Civil Engineering
 भारतीय प्रौद्योगिकी संस्थान मुंबई
 Indian Institute of Technology Bombay
 पवई / Powai मुंबई / Mumbai - 400 076 INDIA

TYPICAL C/S FOR RCC SWD / CULVERT FOR VEHICULAR TRAFFIC

{Below Road}

[Signature]
 DY. CH. E. (S.W.D.) W.S.

[Signature]
 DY. CH. E. (S.W.D.) E.S.

[Signature]
 DY. CH. E. (S.W.D.) CITY.

[Signature]
 CH. ENG. (S.W.D.)

[Signature]
 D.M.C. (INFRA)

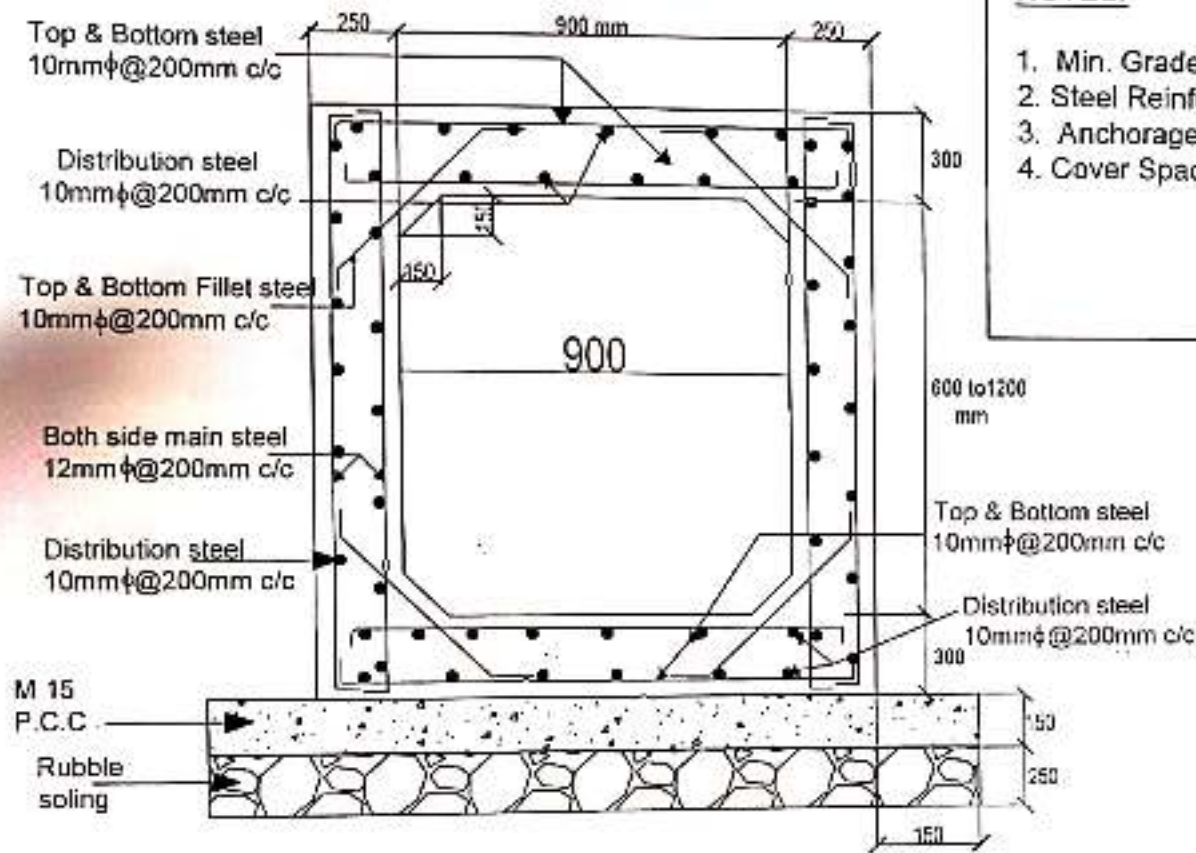

NOTES:

1. Min. Grade of Concrete = M-40.
2. Steel Reinforcement of Grade = Fe500 / Fe500D
3. Anchorage length for all Main Reinforcement = 250mm
4. Cover Space = 40 mm

All Dimensions in mm.
Not to Scale.

CASE 2 :- CLEAR WATER WAY WIDTH 900 MM

J.D. 11/2/2020

डॉ. जयदीप्ता घोष / Dr. Jayadipta Ghosh
सहायक प्राध्यापक - Assistant Professor
सिद्धि अभियांत्रिकी विभाग
Department of Civil Engineering
भारतीय प्रौद्योगिकी संस्थान मुंबई
Indian Institute of Technology Bombay
पवई / Powal मुंबई / Mumbai - 400 076 INDIA

TYPICAL C/S FOR RCC SWD / CULVERT FOR VEHICULAR TRAFFIC
{Below Road}

DY. CH. E. (S.W.D) W.S. | DY. CH. E. (S.W.D) E.S. | DY. CH. E. (S.W.D) CITY | CH. ENG. (S.W.D) | D.M.C. (INFRA)

4127

NOTES:

1. Min. Grade of Concrete = M-40
2. Steel Reinforcement of Grade = Fe500 / Fe500D
3. Anchorage length for all Main Reinforcement = 250mm
4. Cover Space = 40 mm

All Dimensions in mm.
Not to Scale.

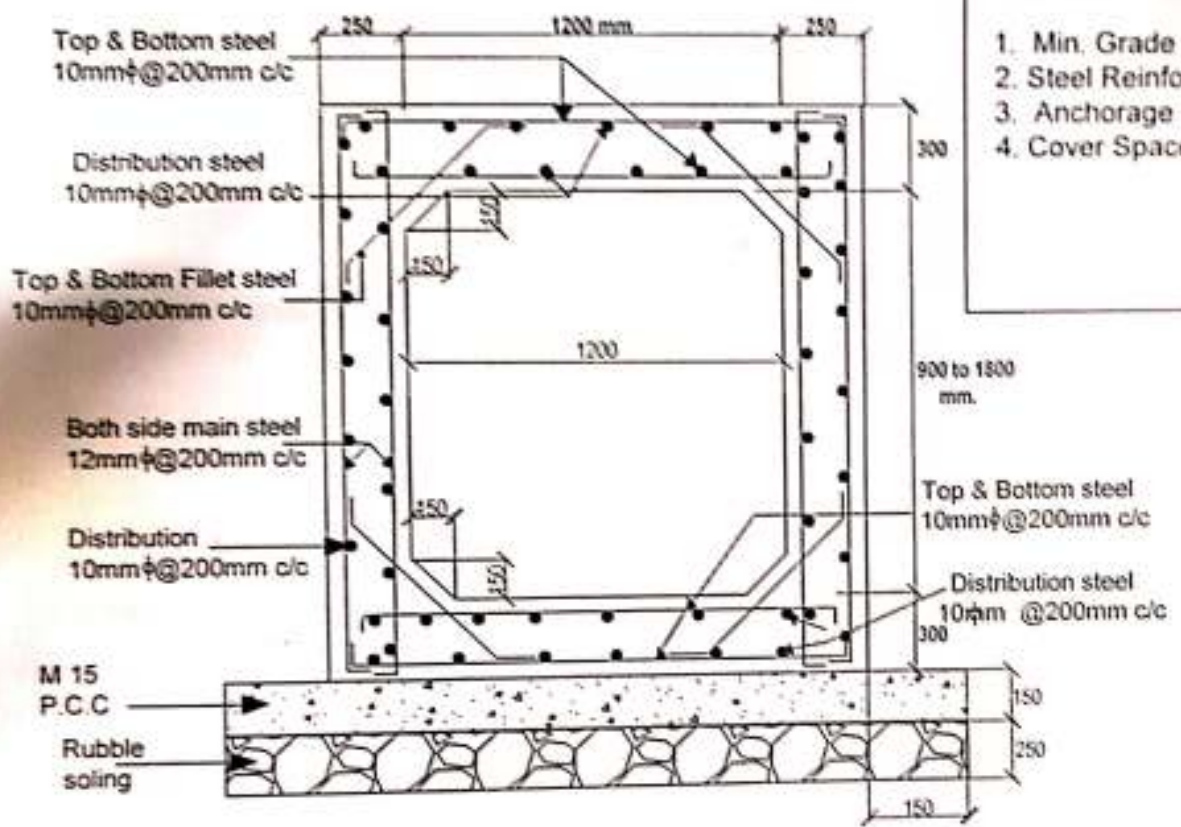

CASE 3 :- CLEAR WATER WAY WIDTH 1200 MM

[Signature]

11/2/2020

डॉ. जयदीप्ता घोष / Dr. Jayaditya Ghosh
 सहायक प्राध्यापक - Assistant Professor
 सिविल अभियंता विभाग
 Department of Civil Engineering
 भारतीय प्रौद्योगिकी संस्थान मुंबई
 Indian Institute of Technology Bombay
 पवई / Powal मुंबई / Mumbai- 400 076 INDIA

**TYPICAL C/S FOR RCC SWD / CULVERT FOR VEHICULAR TRAFFIC
{Below Road}**

DY. CH. E. (S.W.D.) W.S. *[Signature]* 21/8/20
 DY. CH. E. (S.W.D.) E.S. *[Signature]* 21/8/20
 DY. CH. E. (S.W.D.) CITY *[Signature]* 21/8/20
 CH. ENG. (S.W.D.) *[Signature]* 21/8/20
 D.M.C. (INFRA) *[Signature]* 21/8/20

PRODUCED BY AN AUTODESK EDUCATIONAL PRODUCT

PRODUCED BY AN AUTODESK EDUCATIONAL PRODUCT

Scanned with CamScanner

- NOTES:**
1. Min. Grade of Concrete = M-40,
 2. Steel Reinforcement of Grade = Fe500 / Fe500D
 3. Anchorage length for all Main Reinforcement = 300 mm
 4. Cover Space = 40 mm
- All Dimensions in mm.
Not to Scale.

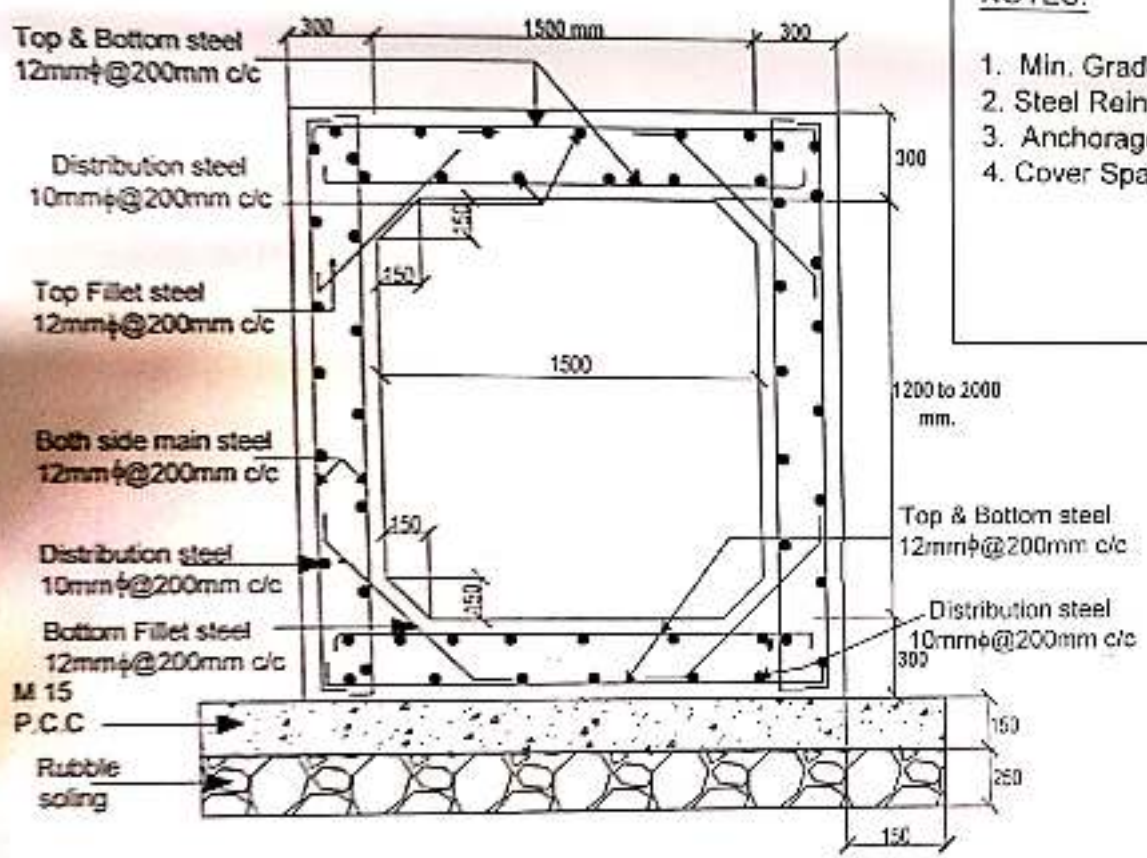

CASE 4 :- CLEAR WATER WAY WIDTH 1500 MM

 11/2/2020
 डॉ. जयदीप्ता घोष / Dr. Jayadipta Ghosh
 सहायक प्राध्यापक - Assistant Professor
 सिविल अभियांत्रिकी विभाग
 Department of Civil Engineering
 भारतीय प्रौद्योगिकी संस्थान मुंबई
 Indian Institute of Technology Bombay
 पणई / Powai मुंबई / Mumbai-400 076 INDIA

TYPICAL C/S FOR RCC SWD / CULVERT FOR VEHICULAR TRAFFIC
{Below Road}

 DY-CH-E (S.W.D.) W.S.
 DY-CH-E (S.W.D.) E.S.
 CH. ENG. (S.W.D.)
 21.9.2008
 D.M.C (INFRA)

PRODUCED BY AN AUTODESK EDUCATIONAL PRODUCT

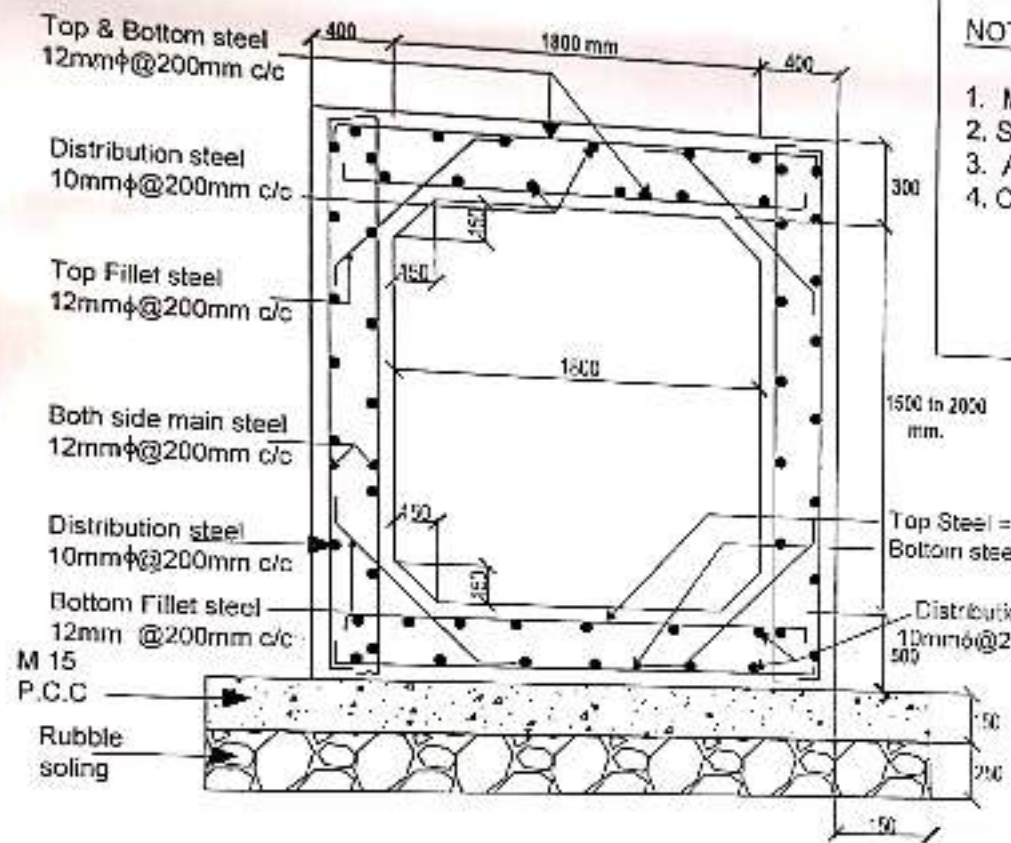

- NOTES:**
1. Min. Grade of Concrete = M-40.
 2. Steel Reinforcement of Grade = Fe500 / Fe500D
 3. Anchorage length for all Main Reinforcement = 300 mm
 4. Cover Space = 40 mm
- All Dimensions in mm.
Not to Scale.

CASE 5:- CLEAR WATER WAY WIDTH 1800 MM

JG

11/2/2020

डॉ. जयदीप घोष / Dr. Jayadipa Ghosh
 सहायक प्राध्यापक - Assistant Professor
 सिविल अभियंत्रित्व विभाग
 Department of Civil Engineering
 भारतीय प्रौद्योगिकी संस्थान मुंबई
 Indian Institute of Technology Bombay
 पवई / Powai मुंबई / Mumbai - 400 076 INDIA

**TYPICAL C/S FOR RCC SWD / CULVERT FOR VEHICULAR TRAFFIC
 (Below Road)**

JG
22/11/20
UB
3.8
JG
2/12/20
JG
21.9.2020

DY-CH-E-CS-W-D] W.S. | DY-CH-E(S-W-D) E.S. | DY-CH-E(S-W-D) CITY | CH-ENG(S-W-D) | D-M-C (INFRA)

PRODUCED BY AN AUTODESK EDUCATIONAL PRODUCT

2/33

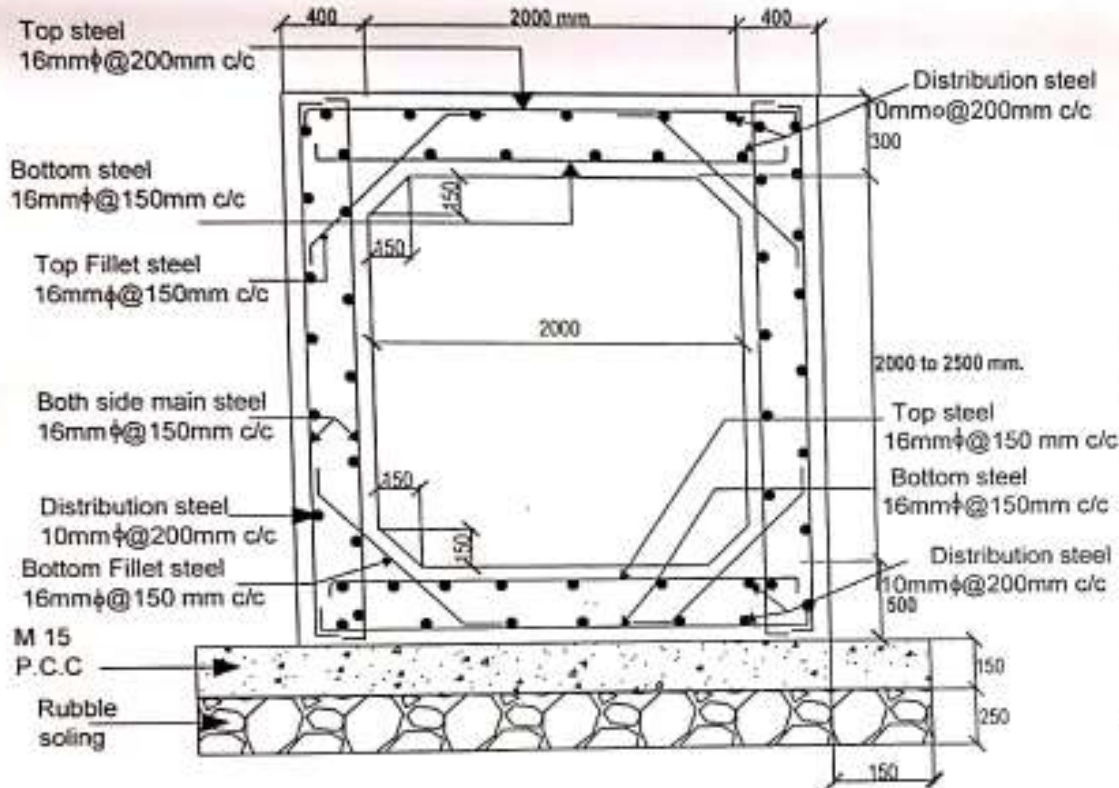

CASE 6 :- CLEAR WATER WAY WIDTH 2000 MM

NOTES:

1. MIN. GRADE OF CONCRETE = M-40.
2. GRADE OF STEEL REINFORCEMENT = Fe500 / Fe500D.
3. ANCHORAGE LENGTH OF MAIN REINFORCEMENT :-
 - a) TOP SLAB : BOTTOM STEEL = 300
TOP STEEL = 250
 - b) RAFT : BOTTOM STEEL = 250
TOP STEEL = 350
 - c) SIDE WALLS : MAIN STEEL = 250

ALL DIMENSIONS IN MM
NOT TO SCALE

[Signature] 11/2/2020
 डॉ. जयदीपा घोष / Dr. Jayadipta Ghosh
 सहायक प्राध्यापक - Assistant Professor
 सिविल अभियंत्रिणी विभाग
 Department of Civil Engineering
 भारतीय प्रौद्योगिकी संस्थान मुंबई
 Indian Institute of Technology Bombay
 Powai मुंबई / Mumbai - 400 076 INDIA

**TYPICAL C/S FOR RCC SWD / CULVERT FOR VEHICULAR TRAFFIC
{Below Road}**

<i>[Signature]</i> DY-CH-E (S.W.D.) WS.	<i>[Signature]</i> DY-CH-E (S.W.D.) E.S.	<i>[Signature]</i> DY-CH-E (S.W.D.) CITY.	<i>[Signature]</i> CH-ENG (S.W.D.) ilc	<i>[Signature]</i> D.M.C. (INFRA) 1/35
--	---	--	--	--

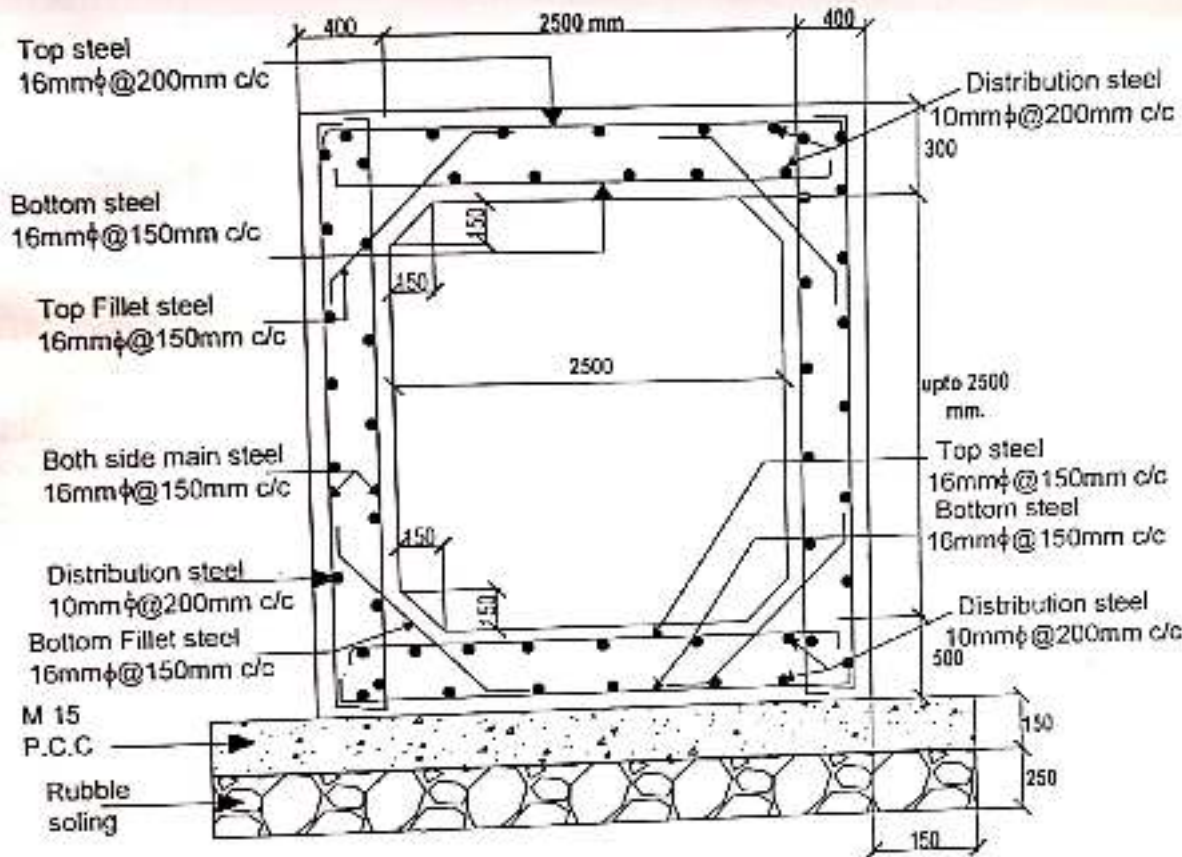

NOTES:

1. MIN. GRADE OF CONCRETE = M-40.
2. GRADE OF STEEL REINFORCEMENT = Fe500 / Fe500D.
3. ANCHORAGE LENGTH OF MAIN REINFORCEMENT :-
 - a) TOP SLAB : BOTTOM STEEL = 350
TOP STEEL = 300
 - b) RAFT : BOTTOM STEEL = 250
TOP STEEL = 350
 - c) SIDE WALLS : MAIN STEEL = 250

ALL DIMENSIONS IN MM
NOT TO SCALE

[Signature] 11/2/2020

डॉ. जयदीप्ता घोष / Dr. Jayadipta Ghosh
सहायक प्राध्यापक - Assistant Professor
सिविल अभियंत्रिकी विभाग
Department of Civil Engineering
भारतीय प्रौद्योगिकी संस्थान मुंबई
Indian Institute of Technology Bombay
पै/ Powal मुंबई / Mumbai - 400 076 INDIA

CASE 7 :- CLEAR WATER WAY WIDTH 2500 MM

**TYPICAL C/S FOR RCC SWD / CULVERT FOR VEHICULAR TRAFFIC
(Below Road)**

[Signature] 22/10/20
DY-CH-E (S.W.D.) W.S.

[Signature]
DY-CH-E (S.W.D.) E.S. DY-CH-E (S.W.D.) CITY
PRODUCED BY AN AUTODESK EDUCATIONAL PRODUCT

[Signature] 21/11/20
CH-ENG (S.W.D.)
jc

[Signature] 21/11/20
D.M.C. (INFRA)

बृहन्मुंबई महानगरपालिका विधी खाते

परिपत्रक क्र. 10318 दि. 24.03.2022

विषय - कंत्राट करार करण्यासाठी वसूल करावयाचे विधी आकार (Legal charges) व लेखनसाहित्य आकार (Stationery charges)

- संदर्भ - 1. विधी खात्याचे परिपत्रक क्र. 03 दि. 22.06.2021
2. परिपत्रक क्र. सीए/एफआरएम/49 दि. 07.02.2013
3. क्र. सीए/एफआरएम/एफआय/82 दि. 07.03.2022

.....

महानगरपालिकेच्या विविध खात्यांमार्फत मागविण्यात येणा-या निविदांसंदर्भात लेखी करार करताना पक्षकाराकडून एकत्रितरित्या आकारावयाच्या विधी आकार व लेखनसाहित्य आकाराची उपरोक्त संदर्भित क्र. 1 वरील परिपत्रकानुसार दि. 01.04.2021 पासून आकारणी करण्यात येते.

तथापि महापालिकेच्या विविध खात्यांच्या आकार/शुल्कसूचीमध्ये नियमित वाढ करण्याबाबत परिपत्रक क्र. सीए/एफआरएम/49 दि. 07.02.2013 अन्वये, दरवर्षी 1 एप्रिल या दिनांकापासून शुल्कसूचीतील दरामध्ये 10 टक्के इतकी वाढ करून पुढील रु.10/- च्या पूर्णांकात दर लागू करण्याबाबतच्या सूचना प्रसूत करण्यात आलेल्या आहेत. त्यानुसार खालील तक्त्यामध्ये दर्शविल्याप्रमाणे सुधारीत विधी व लेखन साहित्य आकार (एकत्रितरीत्या) विहित करण्यात आले आहेत.

अनु. क्र	कंत्राट करार करण्यासाठी एकत्रितरित्या आकारावयाच्या विधी व लेखन साहित्य आकारांसाठी कंत्राट कराराची रक्कम	एकत्रितरित्या आकारावयाचे सुधारीत विधी व लेखन साहित्य आकार दि. 01.04.2022 पासून दि. 31.03.2023 पर्यंत
1	रु. 10,0001 ते रु. 50,000	निरंक
2	रु. 50,001 ते रु. 1,00,000	रु. 6,290/-
3	रु. 1,00,001 ते रु. 3,00,000/-	रु. 10,380/-
4	रु. 3,00,001 ते 5,00,000/-	रु. 12,470/-
5	रु. 5,00,001 ते रु. 10,00,000/-	रु. 14,510/-
6	रु. 10,00,001 ते रु. 20,00,000/-	रु. 16,570/-
7	रु. 20,00,001 ते रु. 40,00,000/-	रु. 18,660/-
8	रु. 40,00,001 ते रु. 1,00,00,000/-	रु. 20,720/-
9	रु. 1,00,00,001 ते रु. 10,00,00,000/-	रु. 24,450/-
10	रु. 10,00,00,001 ते रु. 20,00,00,000/-	रु. 28,220/-

11	रु. 20,00,00,001 ते रु. 30,00,00,000/-	रु. 31,980/-
12	रु. 30,00,00,001 ते रु. 40,00,00,000/-	रु. 35,740/-
13	रु. 40,00,00,001 ते रु. 50,00,00,000/-	रु. 39,470/-
14	रु. 50,00,00,000 ते रु. 1,00,00,00,000/-	रु. 47,000/-
15	रु. 1,00,00,00,001 ते रु. 2,00,00,00,000/-	रु. 58,270/-
16	रु. 2,00,00,00,001 ते रु. 3,00,00,00,000/-	रु. 65,770/-
17	रु. 3,00,00,00,001 ते रु. 4,00,00,00,000/-	रु. 75,120/-
18	रु. 4,00,00,00,001 ते रु. 5,00,00,00,000/-	रु. 84,510/-
19	रु. 5,00,00,00,00 पासून कोणत्याही मर्यादितपर्यंत	रु. 93,920/-

Mudde
हस्ताक्षरे

(सुखश्री मि. मोदले)

उप कायदा अधिकारी (हस्तांतरण 1 व 2)
विधि खाते

(सुनिल क. खोसवणे)

कायदा अधिकारी
विधि खाते

परिपत्रक क्र. 10318 दि. 24.03.2022

प्रत यांना माहितीकरीता व पुढील
आवश्यक त्या कार्यवाहीकरीता अग्रेषित.

(संधिप मो. पाटील)

उप कायदा अधिकारी (आस्थापना)
विधि खाते

59	सहाय्यक आयुक्त 'ई' विभाग	77	प्रमुख अग्निशमन अधिकारी
60	सहाय्यक आयुक्त 'एफ/दक्षिण' विभाग	78	महाव्यवस्थापक, देयनार पशुवधगृह
61	सहाय्यक आयुक्त 'एफ/उत्तर' विभाग	79	प्रमुख सुरक्षा अधिकारी
62	सहाय्यक आयुक्त 'जी/दक्षिण' विभाग	80	अनुज्ञापन अधिकारी
63	सहाय्यक आयुक्त 'जी/उत्तर' विभाग	81	प्रमुख निरीक्षक (दुकाने व आस्थापना)
64	सहाय्यक आयुक्त 'एच/पूर्व' विभाग	82	प्रमुख राजशिष्टाचार व संपर्क अधिकारी
65	सहाय्यक आयुक्त 'एच/पश्चिम' विभाग	83	मानव संसाधन सगन्धक (कार्यकारी)
66	सहाय्यक आयुक्त 'के-पूर्व' विभाग	84	प्रमुख कर्मचारी अधिकारी
67	सहाय्यक आयुक्त 'के-पश्चिम' विभाग	85	सहप्रमुख कर्मचारी अधिकारी (आस्था.)
68	सहाय्यक आयुक्त 'एल' विभाग	86	सहप्रमुख कर्मचारी अधिकारी (मांगासर्व कक्ष)
69	सहाय्यक आयुक्त 'एम/पूर्व' विभाग	87	सहप्रमुख कर्मचारी अधिकारी (एमपीएम)
70	सहाय्यक आयुक्त 'एम/पश्चिम' विभाग	88	रचना व कार्यपध्दती अधिकारी (आ.का.)
71	सहाय्यक आयुक्त 'एन' विभाग	89	प्रशासकीय अधिकारी (समिती)
72	सहाय्यक आयुक्त 'पी/दक्षिण' विभाग	90	प्रशासकीय अधिकारी (तक्रार निवारण)
73	सहाय्यक आयुक्त 'पी/उत्तर' विभाग	91	प्रशासकीय अधिकारी (एमजीसी)
74	सहाय्यक आयुक्त 'आर/दक्षिण' विभाग	92	प्रशासकीय अधिकारी (मराठी परीक्षा)
75	सहाय्यक आयुक्त 'आर/मध्य' विभाग	93	प्रमुख कामगार अधिकारी
76	सहाय्यक आयुक्त 'आर/उत्तर' विभाग		

पुणे नगरपालिका
प्रमुख अभियंता (रस्ते व कचरा)
यांचे कार्यालय
- 6 APR 2022
(2P)
क्र.प्र.अ. (रस्ते) 91

क्र. प्र.अ. / 91 रस्ते.
दि. 20/04/2022

प्रत माहितीसाठी व उचित कार्यवाहीसाठी
कृपया सादर.

मुख्याभिप्रेक (व्यय)
लक्षणे
20/04/2022

E.E. (Road) [Red] [Exp] [CC] [To] [Sub]
E.E. (Road) [Red] [Exp] [CC] [To] [Sub]
E.E. (Road) [Red] [Exp] [CC] [To] [Sub]
[Red] [Exp] [CC] [To] [Sub]
[Red] [Exp] [CC] [To] [Sub]
For Necessary Action & Report
By Ch. Eng. [Red] [Exp] [CC] [To] [Sub]

कार्य. जवि. प्रसा. प्रि. (रस्ते व कचरा)
[Red] [Exp] [CC] [To] [Sub]
[Red] [Exp] [CC] [To] [Sub]

Dr. Puro mail to. Exd AE
[Red] [Exp] [CC] [To] [Sub]

पुणे नगरपालिका
सहप्रमुख अभियंता रस्ते
(प. उप.) यांचे कार्यालय
दिनांक 02 MAY 2022
871
क्र. उप. प्र. अभि (रस्ते)

MUNICIPAL CORPORATION OF GREATER MUMBAI

No: MGC/ F/ 4255 dated: 10.08.2017

Annexure "I" to trench policy issued u/no AMC/ES/7725/II dated 18.12.2014

Sub: Guidelines on trenching procedure along project roads before improvement through ongoing contracts.
Ref: Trench guidelines issued u/no:
1. AMC/ES/7725/II dated 18.12.2014
2. Ch E/1165/Rds/MC dated 29.07.2016

Exhaustive guidelines on trenching policy have been issued vide circular u/no AMC/ES/7725 of 18.12.2014 which have been modified from time to time by issuing circulars.

Vide circular u/no Ch E/1165/Rds/MC dated 29.07.2016 issued in this regard, it was stipulated that to achieve proper placement of utilities and to avoid excavations along newly improved project roads, Ward Road Engineer (Ward RE) shall coordinate with Central Agency Sub Engineers in charge of the site and organize trenching activities for planned trenches of utility agencies in such a manner that all the trenches are taken when the project road is excavated for comprehensive improvement. Over a period, it is observed that this aspect of the policy is being grossly ignored and trench permits are being issued indiscreetly leading to trenches remaining unattended along project roads still to be improved. The provisions of this circular are in respect of the trenches to be allowed to utility agencies along un-improved stretches of project roads under ongoing contract.

As per contract conditions, the project road contractor shall maintain the project roads in motorable condition free of cost during the contract period by carrying out required repairs. The said condition does not stipulate that the project contractor must reinstate the trenches free of cost for which MCGM has given regular permission. It is observed that AE (Maint) of ward issues permit to the utility agencies to take trench along un-improved stretches of project roads without taking in to account this fact. As the work of reinstatement of such trenches is beyond scope of contract, the project road contractor does not reinstate it. The trench remains unattended. Such situation leads to deadlock which results in serious road maintenance issue. The unattended trench affects the day to day life of commuters adversely and at times may result in fatal accidents.

On the other hand, in certain cases where the contract period includes more than one monsoon, some of the project roads may be taken up for improvement during next or next to next fair season. Utility agencies submit their annual trenching plans to respective wards beforehand for planned trenches to be taken in current fair season. If a project road is not taken up for excavation in current fair season then in such case the utility agency despite having submitted the annual trenching plan beforehand will not be in position to take the trench because as per the trench guidelines, the trench for planned activity is to be taken once the project road is excavated for comprehensive improvement. This may result in delay in providing essential services like, communication lines like OFCs, electric cables, MTNL lines, water main/pipes, MGL lines etc.

On this background, it has become expedient to review the situation.

Considering the issue at hand, following guidelines are being issued:

1. In case of project roads which are proposed to be improved during current fair season, AE (Maint) of ward will issue permit to the utility agency just before the commencement of excavation of road by project road contractor for comprehensive improvement, so that trench for laying utility services is excavated only when the road is excavated for improvement. Reinstatement of such trench will then be carried out by project road contractor while carrying out comprehensive improvement of the road, so that separate payment for the reinstatement of trenches is not made
2. In case of the roads which are planned to be improved during next fair season, the utility agency shall not be kept on wait till the project road contractor excavates the road. The utility agency shall be issued permit by recovering requisite reinstatement charges. Simultaneously, work order (PO) for reinstatement of the trench shall be issued to the project road contractor. The project road contractor will reinstate the trench under supervision of Sub Engineer from central agency in charge of the site. The measurement book will be prepared by him. It will be signed by him and the concerned AE (Roads) from Central Agency. The AE (Roads) shall forward the measurement book to AE (Maint) of ward. The payment certificate will be generated by concerned RE and payment for the work executed will be processed by AE (Maint). It will be responsibility of the project road contractor to maintain the road in motorable condition till it is excavated for comprehensive improvement.

3. The ward Road Engineer (RE) shall constantly coordinate with Sub Engineer in charge of site of ongoing projects being executed by Central Agency. It will be responsibility of the ward Road Engineer (Ward RE) to obtain program of project road improvement from the Sub Engineer in charge of project road and accordingly plan the permit schedule for planned trenches of utility agencies. It shall be ensured by him that for the stretches of the roads being improved in current fair season, the utility agency takes the trench just prior to excavation of project road by project road contractor for comprehensive improvement of the road. If there is lack of coordination by Ward RE with Sub Engineer in charge of the project road and if utility agency takes the trench in stretch where the improvement of road is not immediately scheduled during current fair season and for this reason if the trench remains unattended for unreasonably long period or per force if such trench is required to be reinstated through project road contractor by making payment then the ward RE will be held responsible and disciplinary action will be initiated against him.
4. In case where the project road is proposed to be improved in part stretch during current fair season and remaining stretch is planned to be improved during next fair season then excavation permit shall be issued to the utility agency for the entire trench length as per its annual trenching plan even if it exceeds the length of project road to be improved during current fair season. For the length of project road proposed for improvement during next fair season, the project road contractor shall reinstate the trench in the manner as stipulated in para **2** above and the payment for the work executed shall be made by AE (Maint) of ward. About the stretch of road being improved during current fair season, the utility agency shall be instructed to take the trench when the road is taken for excavation by project road contractor. Reinstatement of such trenches will be carried out by project road contractor along with comprehensive improvement of the road as spelt out in para **1** above. Separate payment for reinstatement in such case shall not be made to the project road contractor.
5. Reinstatement of trenches by project road contractor along existing asphalt roads shall be done in 60/70 grade bitumen (VG 20 bitumen). In case of existing paver block roads, it shall be done in 80MM thick paver blocks. For paver blocks, minimum 40% old paver blocks shall be used.

6. The payment to be made to the project road contractor for reinstatement of trenches under provisions of this circular shall be made at the rates quoted by him on the project road contract.

AE (Maint) shall invariably forward one copy of the trench permit to office of Dy Chief Engineer (Roads) on email as well as in hard copy format. It shall be mentioned therein that the utility agency shall take the trench in strict coordination with Central Agency.

This circular comes in to force with immediate effect

sd/- 03.08.2017
Ch E (Roads & Tr)

sd/- 05.08.2017
AMC (ES)

sd/- 09.08.2017
Municipal Commissioner

MUNICIPAL CORPORATION OF GREATER MUMBAI

No: Ch. Eng / 160/5R / Rds & Tr dtd 15 JUN 2021

CIRCULAR

Sub: - Modifications / Amendments to certain provisions of Guidelines for Trenching activity-2015

Ref: - 1. Guidelines for trenching activity-2015 u/no. AMC/ES/7725/II dtd. 18.12.2014

2. Circular u/no: AMC/ES/ 9923/II dtd 20.07.2015

3. Circular u/no: AMC/ES/076/II/ dated 04.08.2015.

4. Circular u/no: MGC/F/4255 dated 10.08.2017.

5. NO: Ch.Eng / 8412/ Rds & Tr dtd 02.02.2019.

6. Approval of Hon'ble MC u/no MGC/F/ 4236 dtd 30.04.2021

Guidelines for trenching activity-2015 have been issued u/no. AMC/ES/7725/II dtd. 18.12.2014. Certain modifications have been incorporated in the said guidelines vide Circulars referred at Sr. No. 2 & 3 above. A separate reinstatement charges rate list vis-a-vis trench size and road surface was circulated along with amended trenching guidelines issued vide circular referred at Sr. No. 3 above which was based on USOR for Road Work 2013. Schedule of flat rates was incorporated in the said circular as Annexure-I. Further, typical cross sections of trench reinstatement on Asphalt roads and Footpaths/Passage for trench size 1.0 M X 1.50 M were incorporated in the said circular along with sample estimates, as Annexure-D-I, Annexure F-I, Annexure C-I and Annexure E-I. The revised USOR for Road Works 2018 has come in force from June 2018 and after verification of the flat rates of RI charges by considering the relevant item rates as per revised USOR for Road Work 2018, the prevailing flat rates of RI charges mentioned in earlier circular vide no AMC/ES/076/II dated 04.08.2015 were continued. The circular to that effect was issued u/no: Dy.Ch.E./ 1039 /Rds/Planning dated 20.08.2018.

As per the present practice, MCGM roads between 6.00 m to 13.40 m width in suburbs and 6.00 m to 12.00 m in City area are being constructed in. C. C. Passage. Other, new methodologies for improvement of carriageway and footpaths of MCGM Roads such as UTWT for carriageway improvement, side strips in C. C. and footpaths with plain C. C. with brooming texture/ stencil concrete and C. C. with marble chips finish are introduced recently. The prevailing circular referred above at Sr. No. 3 above does not include rates for RI charges for these new surfaces of carriageway & footpaths of MCGM Roads. Also, typical

cross section and sample estimates for trenches taken on MCGM roads constructed/improved in Cement Concrete, 25mm & 40 mm thick Mastic Asphalt, TWT, Carriageway finished with paver blocks & Footpath finished in concrete / shot blast, are not included in the said circular. Further, some new guidelines/circulars are issued subsequent to issue of circular referred at sr. No. 1 to 3 above such as: - No separate payments for barricading, no separate payments for removal of excess of excavated materials, Dense Bituminous macadam with 4.50% bitumen content of grade VG-30 bitumen with 50mm thickness, Hot Bituminous macadam with 6.00 % bitumen content of grade VG-30 bitumen with 30 mm thickness, which has lead to the modifications in the process of road improvement work. As such it is necessary to modify the earlier trenching guidelines issued vide circular u/no.AMC/ES/076/II dated 04.08.2018, 1) by modifying the flat rates for surfaces of footpaths/ carriageway of MCGM roads mentioned in the said circular along with typical cross sections and sample estimates as per USOR 2018 for road work and 2) by including the flat rates of RI charges along with typical cross sections and sample estimates as per USOR 2018 for Road Work for reinstatement of trenches taken on MCGM roads improved with new methodologies such as carriageway improved in UTWT, C. C. passages and C. C. side strips & footpaths improved in plain C. C. with brooming texture / stencil concrete and C. C. with top marble chips finishing.

Further, DLP of carriageway of MCGM roads constructed in cement concrete (P.Q.C.) is now 10 yrs instead of 5 yrs earlier. As such, it is necessary to modify table 'D' of Annexure 'A' regarding multiplying factor to be applied for calculating RI charges to be recovered from external utility agencies for reinstatement of trenches taken on MCGM Roads under DLP.

Therefore, the existing trenching guidelines issued vide circular u/no. AMC/ES/076/II dated 04.08.2015 is further modified/amended; 1) by modifying the new flat rates of RI charges to be recovered from external utility agencies as per USOR 2018 for Road Work for reinstatement of trenches taken on footpaths of MCGM roads improved in Concrete/ shot blasted paver block and on carriageway of MCGM roads improved in C. C., TWT, Mastic Asphalt, B.C. & Paver Blocks and 2) by including the flat rates of RI charges to be recovered from external utility agencies, as per USOR 2018 for road work along with typical cross sections and sample estimates for reinstatement of trenches taken on footpaths/carriageway of MCGM roads improved with new methodology such as carriageway improved in UTWT, C. C. passages and C. C. side strips and footpaths improved

in plain C. C. with brooming texture, C. C. with top marble chips finishing, stencil concrete and Annexure regarding modified multiplying factor to be applied for calculating RI charges regarding trenches taken on DLP roads (Annexure 'T'). A separate reinstatement charges rate list vis-a-vis trench size & road surface for standard sizes of trenches i.e. 0.6M X 1.0M, 0.75M X 1.50M and 1.0M X 1.50M (Annexure-J) and typical cross sections and sample estimates (Annexure C-II, E-II, C-III, E-III, C-IV, E-IV, C-V, E-V, D-II, F-II, D-III, F-III, K, K-I, L, L-I, M, M-I, N, N-I, O, O-I, P, P-I, Q, Q-I, R, R-I, S and S-I) and Annexure regarding modified multiplying factor for DLP roads (Annexure 'T') are attached herewith.

Further, the below mentioned notes regarding reinstatement of trenches taken on footpaths/ carriageway of MCGM roads shall be followed scrupulously:-

1. In case of existing footpaths improved in shot blasted Paver Block and having width more than 3.0 m, reinstatement of trench taken shall be done in shot blasted Paver Block.
2. In case of existing footpaths improved in shot blasted Paver Block and having width more than 2.0 m and up to 3.0 m, entire footpath shall be improved in stencil concrete/ C. C. with Top in marble chips finishing /Plain C. C. with brooming texture by recovering additional cost of improvement of portion of footpath which does not fall within the alignment of trench reinstatement, from the concerned utility agencies. A.E. (Maint.) of ward shall work out such additional cost as per USOR for Road Work-2018 and Guidelines for construction footpath issued u/no. Ch.Eng / 8412/ Rds.&Tr. dtd 02.02.2019 in consultation with Ward Executive Engineer.
3. In case of existing footpaths improved in lacquered coated / shot blasted Paver Block and having width less than 2.0 m, reinstatement of trench taken shall be done in C. C. with Top in Marble chips finishing OR Plain C. C. with brooming texture for entire width of footpath.
4. In case of existing footpaths improved in unishaped lacquered coated Paver Block and having width more than 2.0 m, reinstatement of trench taken shall be done in stencil concrete/ C. C. with Top in Marble chips finishing OR in plain C. C. with brooming texture for entire width of footpath by recovering additional cost of improvement of portion of footpath which does not fall within the alignment

of trench reinstatement, from the concerned utility agencies. A.E. (Maint.) of ward shall work out such additional cost as per USOR for Road Work-2018 and Guidelines for construction footpath issued u/no. Ch.Eng/8412/ Rds.&Tr. dtd 02.02.2019 in consultation with Ward Executive Engineer.

5. In case of trenches taken on footpath improved in shot blasted paver block to attend fault, the reinstatement of such trenches shall be done in shot blast paver block only irrespective of width of footpath.
6. In case of trenches taken on footpath improved in lacquered coated paver block / uni-shaped paver block to attend fault, the reinstatement of such trenches shall be done as per the existing surface only. However RI charges shall be recovered from the utility agencies as per the modified rates of footpaths with Concrete finish.
7. If sizes of trenches requested by the utility agencies are not as per the standard prescribed sizes i.e. 0.60 x 1.0 mtrs, 0.75 x 1.50 mtrs & 1.0 x 1.50 mtrs, remarks regarding amount of RI charges to be recovered from them shall be obtained from the respective Zonal Dy.Ch.Eng.(Roads)'s office.
8. Trenches in C. C. surface shall be taken by utility agency strictly by using Diamond Cutter. However, if sizes of the trenches taken on C. C. surface are more than permitted due to negligence of utility agencies, in such case, remarks regarding amount of RI charges to be recovered from utility agency shall be obtained from the respective Zonal Dy.Ch.Eng.(Roads)'s office.
9. In case of Project Road, all trenches should be taken in co ordination with concerned AE.(Roads) of central agency by adopting following norms for recovering reinstatement charges from the concerned utility agencies.
 - a) If trench is proposed on already improved stretch of project road, no trench shall be permitted. If it is very essential, prior approval of Ch.E.(Roads &Tr.) / D.M.C.(Infra) shall be obtained and applicable reinstatement charges in such case shall be recovered from utility agency by considering multiplying factor for first year DLP.

b) If trench is proposed on stretch of project road already excavated by project contractor, concerned RE of ward shall obtain amount of reinstatement charges for reinstatement of trench (below excavated crust) from concerned A.E.(Roads) of Central Agency (including applicable taxes i.e. supervision charges 15%, water charges 8%, sewerage charges 4%)

The existing guidelines for trenching activity-2015 issued under no. AMC/ES/7725/II dated. 18.12.2014 and the circulars regarding modifications/ amendments to certain provisions of the same issued subsequently and which are in force will remain to be in force except for the modifications /amendments as prescribed above, unless and otherwise specified separately.

The circular comes in force with immediate effect.

-sd-	-sd-	-sd-	-sd-
19.03.2021	05.04.2021	09.04.2021	30.04.2021
Ch.Eng (Road & Traffic)	DMC (Infra)	AMC (P)	Hon. M.C.

CIRCULAR

No: Ch. Eng / 160/5R / Rds & Tr dtd **15 JUN 2021**

Copy to,

1. Dir (E.S.&P)	2. D.M.C.(V)	3. D.M.C.(E)	4. D.M.C.(S.E.)
5. C.E.	6. H.E.	7. Ch.E.(Rds.&Tr.)	8. Ch.E.(V)
9. Ch.E.(S.O.)	10. Ch.E.(W.S.P.)	11. Ch.E.(MSDP)	12. Ch.E.(S.W.M.)
13. Ch.E.(P&D)	14. Ch.E.(Bridges)	15. Ch.E.(S.P.)	16. Dy.C.E.(SIC)
17. Ch.E.(M&E)	18. C.A.(F)	19. Ch.E.(C.T.I&R.C.)	20. Ch. C.A.(CPD)
21. Ch.E.(S.W.D.)	22. A.C. K.E.M.Hosp	23. A.C.Nair Hosp	24. A.C.L.T.M.G. Hospital
25. Dy.C.E.(P&D)E.S	26. Dy.Ch.E.(Rds)City	27. Dy.Ch.E.(Rds)W.S	28. Dy.Ch.E.(Rds) E.S
29. Dy.Ch.E.(SWD) City	30. Dy.Ch.E.(SWD) W.S.	31. Dy.Ch.E.(SWD) E.S.	32. Dy.Ch.E.(Bridges)
33. Dy.H.E.(Const)	34. Dy.Ch.E.(P&D)City	35. Dy.H.E.(B.C.)	36. Dy.H.E.(Ops.)O.C
			40. E.E.(BC)W/S

53.	A.C.K/E Ward	54.	A.C.K/W Ward	55.	A.C.P/S Ward	56.	A.C.P/N Ward
57.	A.C.R/S Ward	58.	A.C.R/N Ward	59.	A.C.R/C Ward	60.	A.C. "L" Ward
61.	A.C.M/E Ward	62.	A.C.M/W Ward	63.	A.C. N Ward	64.	A.C.S Ward
65.	A.C.T Ward	66.	EWV (P & R)				

IT deptt has been informed to upload the above mentioned flat rates for recovery of reinstatement charges from utilities agencies for trenching on MCGM roads as per the approval of Hon'ble MC u/no MGC/F/ 4236 dtd 30.04.2021 and the same is in process by them. IT deptt is being informed to close the online trench permit system till the said flat rates are uploaded in CPWM system by them. Hence trench permits shall be issued offline /physically as and when required till the online trench permit system is again made available by the IT deptt.

This circular will be in force from 16.06.2021

f. H. Talwar
Ch.Eng (Road & Traffic)

MUNICIPAL CORPORATION OF GREATER MUMBAI

No: AMC/ES/7725/II dated 20 JUL 2015

Sub: Modifications to the existing trench policy in force.

Exhaustive guidelines have been issued on trenching activities by Administration vide AMC/ES/7725/II dated 18.12.2014; which subsequently came to be modified through various circulars issued from time to time.

There is a need to simplify the procedures for timely processing of trench applications by the ward office. Over a period of time there have been several technological advances. The sizes of utility services/cables have reduced considerably to mere a few inches. Considering this point; need was felt to review the conventional dimensions of the trench with respect to width and depth. Accordingly certain modifications have been made in the policy. In consequence; following guidelines are being issued.

1. The trenching calendar will be from 01st October of every year to 30th September of next year. All the utility agencies will have to submit their annual plans in advance to the concerned Assistant Commissioners in the month of June/July every year. If the annual trenching plan is submitted by the utility agency in the month of June/July; it will not attract additional charge. However, if the annual trenching plans are submitted by the agency in the month of August and September then 5% of applicable RI Charges will be recovered from the utility agency as additional charge over and above the applicable reinstatement charges for all the works to be carried out throughout the respective trench calendar year. Similarly, if the annual plan is submitted in the month of October or thereafter then 7% of applicable RI Charges will be recovered from the utility agency as additional charge over and above the applicable reinstatement charges for all the works to be carried out throughout the respective trench calendar year.

Road Engineers and A.E. (Maint) shall process the applications upon receiving the annual plans during June to September in such a manner that permits are granted by or before 1st October so that the utility

agency should be in a position to take up the work of excavating trench right from 1st October. There shall be only three stages for giving approval i.e. Road Engineer, AE (Maint) and Astt Commissioner of ward

2. Applications for trenching shall be submitted to and then processed by the Road Engineers through AE (Maint) and submitted to Astt Commissioner for approval. Assistant Commissioner will be the approving authority for trenches up-to any length including granting approval for trenches for attending faults in monsoon.

If the application is in order; permission for trenching shall be invariably granted as in default mode

If permit for trench is refused to any agency then strong reasons for such rejection shall be recorded in writing and shall be communicated to the agency.

Henceforth, "NOC" of road department shall not be insisted for any category of road whether CC road, DLP road or project road. However, while permitting excavation along project roads, A.E. (Maint) shall put a condition in the permit that the work shall be commenced and carried out by the utility agency strictly in co-ordination with concerned divisional Dy Ch E (Roads) and by all means before the improvement of the project road is taken by the Central Agency. In turn; it will be the responsibility of concerned Executive Engineer of Roads department to forward current list of DLP Roads, Project roads with all the relevant particulars to AE (Maint) of the respective ward.

3. Ward offices will issue the permit for full length of trench applied by the utility agency by recovering applicable reinstatement charges. However, it shall be stipulated in permit that while executing work on site; the utility agency shall take up work for only 200M in one stretch; complete the cable laying work; back-fill the trench and thereafter take next 200M. Likewise, the utility agency shall carry out the entire work in phases. After backfilling the trench, utility agency shall remove the surplus earth immediately and clear the site. In case of lapses; applicable penalty will be imposed.

4. Maximum width of trench to be excavated by the utility agency will be 0.6M and the maximum depth will be 1.00M. For Gas pipe line /power cables a depth upto 1.5 M with average width of 0.75 M may be permitted with appropriate R.I. Charges if, requested by Utility Agencies.

While calculating RI charges, 5M additional length on either side of trench shall be added to the proposed trench length. The previous provision that 25M length shall be added on either side of the trench is hereby modified.

5. Treatment to be adopted during reinstatement of trenches shall be as per the drawings and sample estimates being supplied herewith. During reinstatement of trench; Maximum 5 layers of granular layer of 75MM thickness shall be operated by MCGM Trench reinstatement contractor. Transportation of surplus earth after reinstatement of trenches will not be paid separately. However; it will be the responsibility of the MCGM contractor to dispose of the said material in a systematic manner and clear the site.

6. The reinstatement charges have been accordingly revised for all categories and the same are as per enclosed annexure "I".

7. The concerned Road Engineer as well as the utility agency shall ensure that, during excavation of the trench, the excavated earth is stacked in systematic manner along property side edge of the trench and that earth shall not spill over outside the barricades. The barricades shall be maintained in neat and clean condition. They must display details of trench work, start date, date of completion etc conspicuously. A sample barricade drawing is enclosed.

8. The applicable penalties for various lapses have been revised and same shall be as per Annexure II.

9. As a pilot experimental initiative to assess impact and feasibility of executing Micro-trench works in monsoon, on demands it is decided to allow micro-Trenching during current monsoon subject to the condition that the works will be carried out by the respective agencies during dry spells only. It shall be ensured by the utility agencies that the Micro-trench is taken in straight alignment along a road. It shall not deviate from the straight alignment and shall not be laid in zigzag

C-7

manner. If such instances are noticed then Rs 5000/- penalty per instance will be imposed. Micro-Trench shall not be permitted across the road. It shall not be allowed in CC carriageway.

10. M.C.G.M. is in the process of introducing online facility for receipt of trenching applications; accepting reinstatement charges and issuing permit. Modalities in this regards will be issued in due course.

This circular supersedes the relevant sections/provisions in contained in previous circular which was issued u/no AMC/ES/7725/II dated 18.12.2014. It will be applicable for external utility service agencies.

For planned works of laying underground services of various MCGM departments, concerned department shall include the work of improvement of trench in their tender with respect to requirement of depth and specified width required for the utility pipe line. However, practice of attending trenches for water works faults attended by AE (WW) shall continued to be reinstated by AE (M) through the Trench contractor, the expenses therefore shall be transferred by CA (WSSD) from G budget to A budget. CA (fin) shall apportion such transferred fund to concerned wards according to the expenses incurred by them.

This circular is based on the basic promise that trenching is an essential requirement for providing services, which are now basic to urban living (e.g. gas, power, data cables). It also presumes that utilitites will exercise caution and will be prudent not to work in a manner that would disrupt normal functioning of the city. The MCGM is confident that utility agencies will follow this circular scrupulously and not violate any of the conditions. In case of violations & execution of work in a manner jeopardizing safety and normal functioning, Municipal Commissioner reserves the right to impose punitive penalty to the extent of Rs. 1 Lakh for every such instance.

This circular comes in to effect with immediate effect.

Ch. E. (Roads & Tr)
10/7/15

A.M.C. (E.S.)

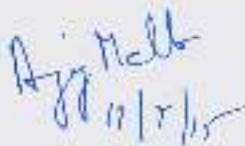
M. C.

S-9 C-9

MUNICIPAL CORPORATION OF GREATER MUMBAI

No: AMC/ES/ /II dated

*Cross section drawings
And
Sample estimates*

No: AMC/ES/ /II dated

ANNEXURE -I

SCHEDULE OF FLAT RATE (GENERAL)

A) ON FOOTPATH

Sr. No.	Existing Surface	Finished to	Rate in Rs. per Rmt.
1	Any surface	Lacquered coated coloured paver blocks (60 mm thick)	6386.00
2	Any surface	Concrete finished	6390.00
3	Any surface	Gray or any specified colour with shot Blasted Texture paver blocks (200X200X60mm)	7009.00

B) ON CARRIAGEWAY

Sr. No.	Existing Surface	Finished to	Rate in Rs. per Rmt.
1	Cement Concrete Carriageway	A) 100 mm thick Paver block immediately B) Cement Concrete Pavement in due course	18596.00
2	TWT Carriageway	A) 100 mm thick Paver block immediately B) Cement Concrete Pavement in due course	12226.00
3	Mastic Asphalt 25 mm thick	Mastic Asphalt 25 mm thick	6541.00
4	Mastic Asphalt 40 mm thick	Mastic Asphalt 40 mm thick	7502.00
5	Bituminous concrete (30/40 grade)	Bituminous concrete (30/40 grade)	6369.00
6	Paver blocks 80mm thick (50% Grey & 50% Red Paver Blocks)	Paver blocks 80mm thick (50% Grey & 50% Red Paver Blocks)	5000.00
7	Paver blocks 80mm thick (Only Grey colour)	Paver blocks 80mm thick (Only Grey colour)	4802.00

8	Paver blocks 100mm thick (50% Grey &50% Red Paver Blocks)	Paver blocks 100mm thick (50% Grey &50% Red Paver Blocks)	5409.00
9	Paver blocks 100mm thick (Only Grey colour)	Paver blocks 100mm thick (Only Grey colour)	5148.00

C) Use of existing duct Rs. 2100/- per meter

**SCHEDULE OF FLAT RATE FOR GAS PIPE LINES /POWER CABLES
A) ON FOOTPATH**

Sr. No.	Existing Surface	Finished to	Rate in Rs. per Rmt.
1	Any surface	Lacquered coated coloured paver blocks (60 mm thick)	6913.00
2	Any surface	Concrete finished	6873.00
3	Any surface	Gray or any specified colour with shot Blasted Texture paver blocks (200X200X60mm)	7708.00

B) ON CARRIAGEWAY

Sr. No.	Existing Surface	Finished to	Rate in Rs. per Rmt.
1	Cement Concrete Carriageway	A) 100 mm thick Paver block immediately B) Cement Concrete Pavement in due course	20399.00
2	TWT Carriageway	A) 100 mm thick Paver block immediately B) Cement Concrete Pavement in due course	13539.00
3	Mastic Asphalt 25 mm thick	Mastic Asphalt 25 mm thick	7015.00
4	Mastic Asphalt 40 mm thick	Mastic Asphalt 40 mm thick	7978.00
5	Bituminous concrete (30/40 grade)	Bituminous concrete (30/40 grade)	6846.00
6	Paver blocks 80mm thick (50% Grey & 50% Red Paver Blocks)	Paver blocks 80mm thick (50% Grey & 50% Red Paver Blocks)	5394.00
7	Paver blocks 80mm thick (Only Grey colour)	Paver blocks 80mm thick (Only Grey colour)	5324.00

8	Paver blocks 100mm thick (50% Grey & 50% Red Paver Blocks)	Paver blocks 100mm thick (50% Grey & 50% Red Paver Blocks)	3681.00
9	Paver blocks 100mm thick (Only Grey colour)	Paver blocks 100mm thick (Only Grey colour)	5574.00

C) Use of existing duct Rs. 2100/- per meter

Typical Cross Section of Trench for Reinstatement on Asphalt Road (General)



Layer wise details for item / materials to be used & its compaction.

Layer No.	SOR 2013 Item No.	Description of Material	Remarks
Layer 1	--	30 CM Cushioning, not necessarily sand metal	Sufficient watering & ramming by Utility
Layer 2	RW-10-28	Sand metal	Sufficient watering & ramming by Reinstatement contractor
Layer 3	RW-10-28	Sand metal	Sufficient watering & ramming by Reinstatement contractor
Layer 4	RW-10-28	Sand metal	Sufficient watering & ramming by Reinstatement contractor
Layer 5	RW-10-28	Sand metal	Sufficient watering & ramming by Reinstatement contractor
Layer 6	RW-10-28	Sand metal	Sufficient watering & ramming by Reinstatement contractor
Layer 7	RW-2-21	Granular subbase	Compaction by 10 Tons Vibratory roller
Layer 8	RW-2-20	Wet mix macadam	Compaction by 10 Tons Vibratory roller

Layer 9	RW-5-44	Premix dense bituminous macadam	Laying by sensor paver & compaction by 10 Tons vibratory roller
Layer 10	RW-5-40	Premix bituminous concrete	Laying by sensor paver & compaction by 10 Tons vibratory roller

Note: Granular material (sand Metal) maximum 5 layers of 75MM thickness shall be provided for the trench depth of 1.0M. For lesser depths of trench; the number of layers of sand metal shall be reduced accordingly.

3	RW-1-18	Leveling, watering & rolling by vibratory roller IID-22 weighing not less than 10 tonnes & preparing the ground to the required grade & camber only to be used for reinstatement for trench in road works as per New Road Specifications.	1.00	10,000	1,500	17.00	Sqm	
4	RW-2-21	Providing & laying, spreading & compacting specified crushed stone in granular sub base course including premixing the material in mechanical mixer (pug mill or approved type), spreading of mixed material in uniform layer of 100 mm to 75 mm etc. complete	1.00	10,000	0.600	0.100	0.60	Cu
5	RW-2-20	Providing & laying, spreading & compacting graded crushed stone aggregate to wet mix macadam satisfaction including premixing the material with water to OMC in mechanical mixer/pug mill carriage of mix material by tipper to site laying in uniform layer of 75 mm to 100 mm etc. complete	1.00	10,000	1,500	0.100	1.50	Cum
6	RW-5-20	Providing and applying PRIME COAT with CATIONIC BITUMEN EMULSION (SS) @ 7 to 12 Kg. On 10 Sqm. Etc complete	1.00	10,000	1,900	19.00	Sqm	
7	RW-5-23	Providing and applying TACK COAT with CATIONIC BITUMEN EMULSION (RS) @ 0.2 to 0.25 Kg. per sqm. On DBM	1.00	10,000	2,400	21.00	Sqm	
8	RW-5-24	Providing and applying TACK COAT with CATIONIC BITUMEN EMULSION (RS) @ 0.25 to 0.30 Kg On W/M	1.00	10,000	1,900	19.00	Sqm	
9	RW-5-45	P/L hot Premix Dense bituminous macadam with 4.50% bitumen content in grade 35-40 to the required line, level, and camber on Prg with 10/12MT. power vibratory						

Note:

- 1) The sample estimate is as per unified schedule of rates effective from 16.09.2017
- 2) Payment for transportation of surplus earth will not be made separately to wind trench reinstatement contractor.
- 3) For barricading, invariably the item RW-7-36 shall be operated

No: AMC/ES/ /II dated

Annexure-C-I

Typical Cross Section of Trench For Reinstatement On Footpath/ Passage (General)

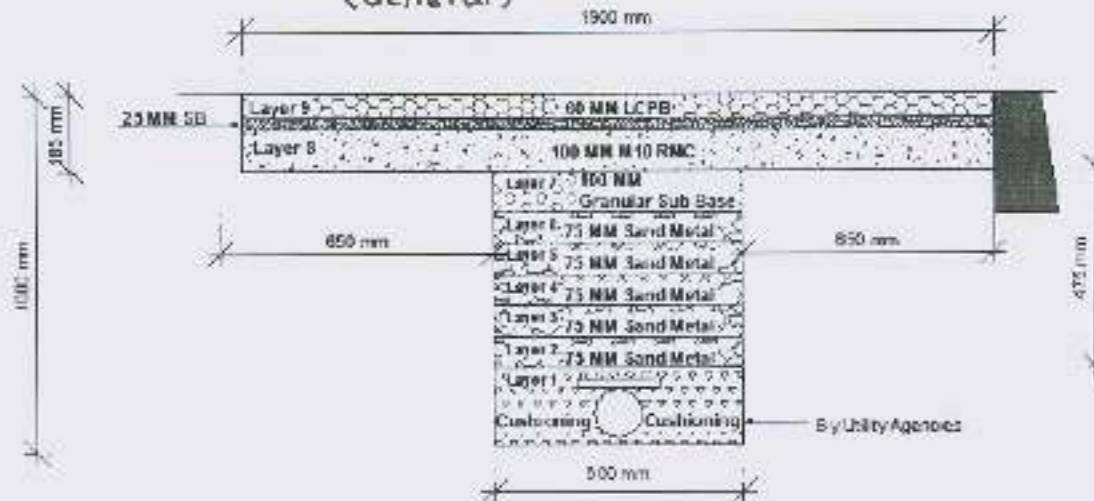

Layer No.	SOR 2013 Item No.	Description of Material	Remarks
Layer 1	--	30 CM Cushioning, not necessarily sand metal	Sufficient watering & ramming by Utility
Layer 2	RW-10-28	Sand metal	Sufficient watering & ramming by Reinstatement contractor
Layer 3	RW-10-28	Sand metal	Sufficient watering & ramming by Reinstatement contractor
Layer 4	RW-10-28	Sand metal	Sufficient watering & ramming by Reinstatement contractor
Layer 5	RW-10-28	Sand metal	Sufficient watering & ramming by Reinstatement contractor
Layer 6	RW-10-28	Sand metal	Sufficient watering & ramming by Reinstatement contractor
Layer 7	RW-2-20	Wet mix macadam	Compaction by 10 Tons Vibratory roller
Layer 8	RW-10-27	RMC M-10	Curing of M-10 PCC
Layer 9	--	Sand Cushioning	--
	RW-3-17 & RW-3-14	60 mm thick lacquer coated paver blocks	--

Note: Granular material (sand Metal) maximum 5 layers of 75MM thickness shall be provided for the trench depth of 1.0M. For lesser depths of trench; the number of layers of sand metal shall be reduced accordingly.

No: AMC/ES/ /II dated

ANNEXURE -E-1

SAMPLE ESTIMATE FOR REINSTATEMENT OF TRENCHES IN 60MM THICK LACQUER COATED PAVER BLOCKS IN FOOTPATH CONSIDERING 1.90M WIDTH, 10M LENGTH, 0.700M DEPTH & 0.60M WIDTH OF TRENCH

Dimensions in mtr.

1	Length of Footpath	10.000
2	Width of the Footpath	1.900
3	Thickness of PCC/ M10	0.100
4	Thickness of WBM Layer	0.100
5	Thickness of Cushioning Sand	0.025
6	Thickness of Paver Blocks	0.060
7	Thickness of Sand Metal	0.175
8	Total Depth of excavation	0.700
9	Excavation depth in Asphalt	0.185
10	Width of Trench	0.600

NO.	ITEM NO.	DESCRIPTION OF ITEM	NO.	LENGTH IN mtr.	WIDTH IN mtr.	DEPTH IN mtr.	QTY.
1	CS-EW-1	Excavation for foundations, substructures, basements, tanks, sunps, walls, chambers, manholes, trenches, poles, pits & general building works in all types of soils, vegetable earth, etc. complete.					
		Trench	1.00	10.00	0.60	0.700	4.20
		Deduction 30% for voids (Inclusive of backfilling 40mm)					-1.26
						Total	2.94
							Cum
2	CS-EW-3	Excavation in formation, substructures, basements, tanks, sunps, walls, chambers, manholes, trenches, poles, pits & general building works in soft/s integrated rock, sandstone, stiff clay, gravel, cobble stone, hard granite, water bound macadam, wet mix macadam, asphalt, mix carpet, Concrete					
		Crust	1.00	10.00	1.300	0.185	2.41
							Cum
3	RW-1-18	Leveling, watering & rolling by vibratory roller H20-22 weighing not less than 10 tonnes & preparing the ground to the required grade & camber to be used for reinstatement fee					

		trench in road works) as per New Road Specification						
			.00	10.000	1.500			15.00
								SQM
4	RW-10-27	P/LR.M.C.M-100.C. having avg. compressive strength 13.5 Mpa. grade in foundation /encement. (pavement with or without obaquered design including formwork, mixing in batch ing plant, placing vibrating with plate or needle curing etc. complete as directed by the Engineer. C's has to make his own arrangement for water for curing with Hessian cloth etc. & will not be paid separately. (MINIMUM CEMENT CONTENT 220 Kg/m ³)						
			1.00	10.000	1.900	0.100		1.90
								Cum
5	RW-2-20	Providing & laying, spreading & compacting graded crushed stone aggregate to wet mix minimum satisfaction including providing the material with water to OMC in mechanical mix (pugnill) carriage of mix material by tapper to site laying in uniform layer of 75mm to 100mm etc. complete.						
			1.00	10.000	2.60	0.100		0.60
								Cum
6	RW-5-17	Providing & fixing in the footpath, 60mm thick Lacquer coated (Reflective) interlocking gray cement concrete paver sized (Elera Cera) Black, Brown, Lemon Yellow or any colour with verticalular or any anti skid texture on top surface of improved pattern/ shape and colour having average crushing strength 40N/mm ² manufactured in double layer precast concrete blocks. The top layer of paver block should be 12 to 15mm thick and consist cubical shape stone aggregate 8mm size sieve 100% passing and retain on 4.75mm size sieve, silica sand with pure ironoxide ultraviolet stabilized pigment @ 3% by weight of cement and should be coated with lacquer having hard, light abrasive resistance and water repellent. The bottom layer						

		should be 45 to 48mm thick having 12mm size sieve 100% passing aggregate as per technical specification placed on uniformly grade drivers and cushioning of average compacted thickness 25mm properly compacted with mechanical compact or with required level, grade and camber etc. complete as specified and as directed by the Engineer.				
		(Considering new paver blocks in trench)	1.00	10.000	0.600	6.00
						Total 6.00
						SQM
7	RW-3-14	Removing & refixing interlocking concrete pavers of 60 mm thick, having of any size, shape and colour considering 10% breakage area of paver blocks while removing same from position and replaced same by new paver blocks having average crushing strength not less than 40 N/mm ² placed on uniformly graded river sand cushioning of average compacted thickness 25 mm properly compacted with mechanical contractor with required level, grade and camber etc. complete as specified and as directed by the Engineer.				
			1	10.00	1.30	13.00
						Rmt.
8	RW-7-36	Flattening the trenches on traffic flow side with 1.60 mtr. Height M.S.Angle post of 50 x 50 x 5 mm. buried in half the depth in drum of 20 ltrs. Capact by 1:3:6 concrete spaced at 2.25 m centre to centre with 22 gauge G.I. corrugated sheet of size 2.40 x 0.75 m, bolted to the M.S. Angle post and painted in yellow and black band with synthetic enamel paint as per traffic norms and as directed by the Engineers.				
			2	2.00		4.00
			2	11.00		22.00
						Total 26.00
						Rmt.

9	RW-10-28	Supply & filling sand, metal GRAVELLY SAND Corresponded to CLASS II CLASS III GRADING of TABLE 100.1of new road specifications-2006 in trenches upto required depth & watering, ranning etc. complete as directed	1.00	10.000	0.600	0.375	0.25
							Cum
10	RW-2-22	Rebate for not using motor grader / paver for laying of Granular Sub base in RW-2-21 Same as item no 4					1.90
							Cum
11	RW-10-60	Providing and fixing of the precast kerb stone of height 325mm., base width 165mm., top width 115mm.in M20grade RMC supplied through MCOM approved plant or concrete mixed with use of weight batch mixer s as detailed in drawing u/No. Dy.Ch.E./Rda/93 /E.S. of 17 / 8 / 2005 , excavation in any soil except rock, laying a leveling course of M 15 grade RMC 100mm. thick, to required slope (inclusive of form work) jointing in C.M 1:2 proportion, finish to concrete surface, painting exposed surface with one coat of primer and two coats of 1st grade road marking paint in the yellow/white-black or any shade as directed. (Kerbstones shall be procured from MCOM registered agencies).	1	10.00			10.00
							Rmt.

- Note:-
- 1) The sample estimate is as per unified schedule of rates effective from 16.09.2013
 - 2) Actual estimate shall however be prepared by adopting items and rates applicable as per prevailing contract of the reinstating agency.
 - 3) Payment for transportation of surplus earth will not be made separately to ward trench reinstatement contractor.
 - 4) For barricading, invariably the item RW-7-36 shall be opened

Typical Cross Section of Trench for Reinstatement on Asphalt Road for Gas Pipe lines / Power cables

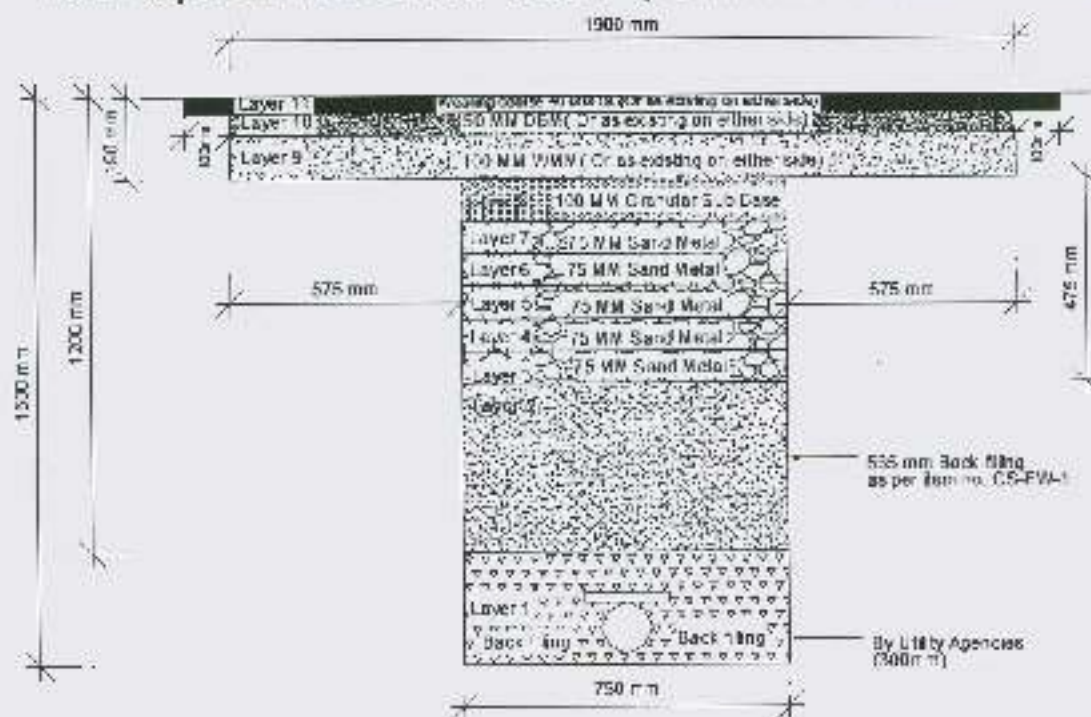

Layer wise details for item / materials to be used & its compaction.

Layer No.	SOR 2013 Item No.	Description of Material	Remarks
Layer 1	--	30 CM Cushioning, not necessarily sand metal	Sufficient watering & ramming by Utility
Layer 2	--	Back filling	Sufficient watering & ramming as per item CS-EW-1 by Reinstatement contractor
Layer 3	RW-10-28	Sand metal	Sufficient watering & ramming by Reinstatement contractor
Layer 4	RW-10-28	Sand metal	Sufficient watering & ramming by Reinstatement contractor
Layer 5	RW-10-28	Sand metal	Sufficient watering & ramming by Reinstatement contractor
Layer 6	RW-10-28	Sand metal	Sufficient watering & ramming by Reinstatement contractor

Layer 7	RW-10-28	Sand metal	Sufficient watering & ramming by Reinstatement contractor
Layer 8	RW-2-21	Granular subbase	Compaction by 10 Tons Vibratory roller
Layer 9	RW-2-20	Wet mix macadam	Compaction by 10 Tons Vibratory roller
Layer 10	RW-5-44	Premix dense bituminous macadam	Laying by sensor paver & compaction by 10 Tons vibratory roller
Layer 11	RW-5-40	Premix bituminous concrete	Laying by sensor paver & compaction by 10 Tons vibratory roller

Note: Granular material (sand Metal) maximum 5 layers of 75MM thickness shall be provided for the trench depth of 1.0M. For lesser depths of trench; the number of layers of sand metal shall be reduced accordingly.

3	RW-1-18	Levelling, watering & rolling by vibratory roller (DIA-22 weighing not less than 10 tonnes & preparing the ground to the required grade & camber (only to be used for reinstatement for trench in road work) as per New Road Specifications.	1.00	10.000	1.150		11.50
							Sqm
4	RW-2-21	Providing & laying, spreading & compacting specified crushed stone in granular sub base course including premixing the material in mechanical mixer (mix mill or approved type), spreading of mixed material in uniform layer of 100 mm to 75mm etc. complete.	1.00	10.000	0.750	0.100	0.75
							Cum
5	RW-2-20	Providing & laying, spreading & compacting graded crushed stone aggregate to wet mix macadam satisfaction including premixing the material with water to OMC in mechanical mix pug mill carriage or mix material by tipper to site laying in uniform layer of 75mm to 100mm etc. complete.	1.00	10.000	1.900	0.100	1.90
							Cum
6	RW-5-20	Providing and applying PRIME COAT with CATIONIC BITUMEN EMULSION (RS) @ 12Kg. Of 10 Smt. per complete.	1.00	10.000	1.900		19.00
							Sqm
7	RW-5-23	Providing and applying TACK COAT with CATIONIC BITUMEN EMULSION (RS) @ 0.2 to 0.25 kg per sqm. On DTM	1.00	10.000	2.150		21.00
							Sqm
8	RW-5-24	Providing and applying TACK COAT with CATIONIC BITUMEN EMULSION (RS) @ 0.25 to 0.30 Kg. Or WMM	1.00	10.000	1.900		19.00
							Sqm
9	RW-5-45	P/1. hot Premix Dense bituminous macadam with 4.50% bitumen content of grade 30-40 to those given line, level, and camber rolling with 10:12M.T. power, vibratory					

		roller & sensor paver etc. complete as specified and as directed to thickness of 50mm. with anti-stripping agent at 1.00% by weight of bituminous in grading II of 'MORTH' (As per new Road Specification clause no.354)					
			1.00	10.000	1.000	19.00	
							Sqm
10	RW-5-40	P4 Hot premix Bituminous concrete with 6.00% of bitumen grade 30/40 surface coat by mix design as per MORTH to the compacted thickness of 40 mm. using new material to the required F.R.C. level and camber rolling with power vibratory roller & sensor paver, etc. complete as specified and as directed with fine filler 5.00% by weight and anti-stripping agent @ 1% of bitumen by weight etc. complete. As per new Road Specification clause no.354)					
			1.00	10.000	2.00	21.00	
							Sqm
11	RW-7-30	Baricading the trenches on traffic flow side with 1.60 mtr. Height M.S. Angle post of 50 x 50 x 5 mm, buried in half the depth in drum of 20 hrs. Gravel by 1:3:6 concrete spaced at 2.25 m centre to centre with 22 gauge G.I. corrugated sheet of size 2.40 x 0.75 m, bolted to the M.S. Angle post and painted in yellow and black band with synthetic enamel paint as per traffic norms and as directed by the Engineers.					
			2	2.00		4.00	
			2	11.00		22.00	
					Total	26.00	
							Rmt.
12	RW-10-28	Supply & filling sand, metal GRAVELLY SAND Corresponded to CLASS II CLASS III GRADING of TABLE 100.1 of new road specifications-2006 in trenches upto required depth & watering, raining etc. complete as directed					
			1.00	10.000	0.750	0.375	2.81
							Cum
13	RW-2-22	Rebate for not using motor grader / paver for laying of Granular Sub base in RW-2-21 Same as item no 4					
						0.75	
							Cum

Note:

- 1) The sample estimate is as per unified schedule of rates effective from 16.09.2011
- 2) Payment for transportation of surplus earth will not be made separately to ward trench reinstatement contractor.
- 3) For barricading, invariably the item RW-7-26 shall be operated

Typical Cross Section of Trench For Reinstatement On Footpath/Passage for Gas Pipe lines/Power cables

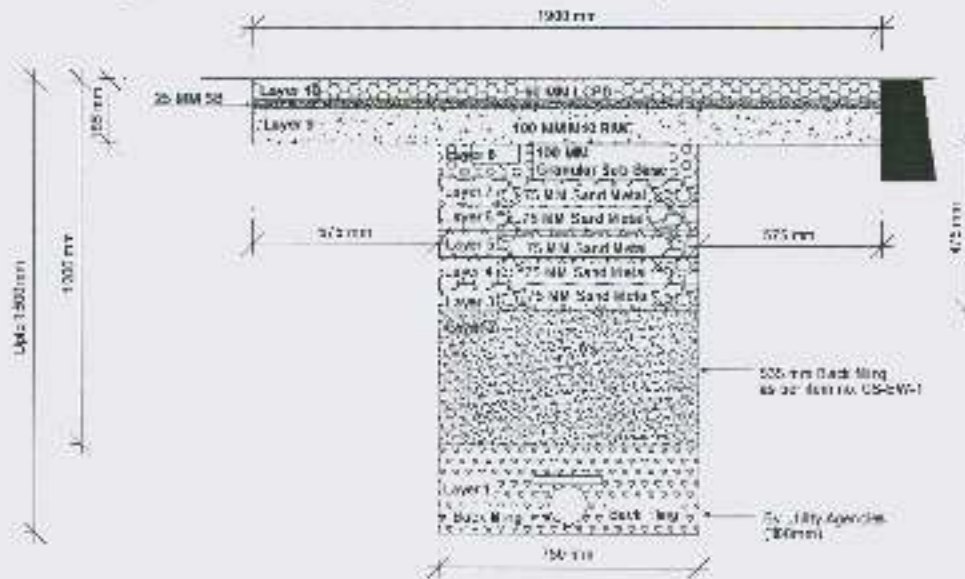

Layer No.	SOR 2013 Item No.	Description of Material	Remarks
Layer 1	--	30 CM Cushioning, not necessarily sand metal	Sufficient watering & ramming by Utility
Layer 2	--	Back filling	Sufficient watering & ramming as per item CS-EW-1 by Reinstatement contractor
Layer 3	RW-10-28	Sand metal	Sufficient watering & ramming by Reinstatement contractor
Layer 4	RW-10-28	Sand metal	Sufficient watering & ramming by Reinstatement contractor
Layer 5	RW-10-28	Sand metal	Sufficient watering & ramming by Reinstatement contractor
Layer 6	RW-10-28	Sand metal	Sufficient watering & ramming by Reinstatement contractor
Layer 7	RW-10-28	Sand metal	Sufficient watering & ramming by Reinstatement contractor
Layer 8	RW-2-20	Wet mix macadam	Compaction by 10 Tons Vibratory roller
Layer 9	RW-10-27	RMC M-10	Curing of M-10 PCC
Layer	--	Sand Cushioning	--
Layer10	RW-3-17 & RW-3-14	60 mm thick lacquer coated paver blocks	--

Note: Granular material (sand Metal) maximum 5 layers of 75MM thickness shall be provided for the trench depth of 1.0M. For lesser depths of trench; the number of layers of sand metal shall be reduced accordingly.

**SAMPLE ESTIMATE FOR REINSTATEMENT OF TRENCHES FOR GAS PIPE LINES /
POWER CABLES IN 60MM THICK LACQUER COATED PAVER BLOCKS IN FOOTPATH
CONSIDERING 1.90M WIDTH, 10M LENGTH, 1.20M DEPTH & 0.75M WIDTH OF TRENCH**

Dimensions in mtr.

1	Length of Footpath	10.000
2	Width of the Footpath	1.900
3	Thickness of PCC M10	0.100
4	Thickness of WMM Layer	0.100
5	Thickness of Cushioning Sand	0.025
6	Thickness of Paver Blocks	0.060
7	Thickness of Sand Metal	0.375
8	Total Depth of excavation	1.200
9	Excavation depth in Asphalt	0.185
10	Width of Trench	0.750

NO.	ITEM NO.	DESCRIPTION OF ITEM	NO.	LENG TH IN mtr.	WIDTH IN mtr.	DEPTH IN mtr.	QTY.
1	CS-FW-1	Excavation for foundations, substructures, basements, tanks, sumps, walls, chambers, manholes, trenches, poles, pits & general building works in all types of soils, vegetable earth, etc. complete					
		Trench	1.00	10.00	0.75	1.200	9.00
		Deduction 30% for voids (Inclusive of backfilling 40mm)					-2.70
						Total	6.30
							Cum
2	CS-FW-3	Excavation for foundation, substructures, basements, tanks, sumps, walls, chambers, manholes, trenches, poles, pits & general building works in soft/disintegrated rock, sandstone, stiff clay, gravel, cobbles stone, hard laterite, water bound macadam, wet mix macadam, asphalt mix carpet, Complete					
		Crust	1.00	10.000	1.150	0.185	2.13
							Cum
3	RW-I-18	Levelling, watering & rolling by vibratory roller JDD-22 weighing not less than 10 tonnes & preparing the ground to the required grade & camber (only to be used for reinstatement for					

		leach in road work) as per New Road Specification							
			1.00	10.000	1.150				11.50
									SQM
4	RW-10-27	<p>PCI R.M.C. M-10C.C. having avg. compressive strength 13.5 Mpa grade in foundation & easement (maximum width, or without chequered design including formwork, mixing in batching plant, placing vibrating with plate or needle curing etc complete as directed by the Engineer) % has to make his own arrangement for water for curing with Hessian cloth etc & will not be paid separately. (MINIMUM CEMENT CONTENT 220 Kgrm³)</p>	1.00	10.000	1.900	0.100			1.90
									Cum
5	RW-2-20	<p>Providing & laying, spreading & compacting graded crushed stone aggregate to wet mix macadam satisfaction including premixing the material with water to OMC in mechanical mixer pugmill carriage of mix material by tipper to site laying it in 100mm layer of 75mm or 100mm etc. complete.</p>	1.00	10.00	0.75	0.100			0.75
									Cum
6	RW-3-17	<p>Providing & fixing in the footpath, 60mm thick Lacquer coated (Reflective) interlocking gray cement concrete paver sintered (Ferro Collo) Black, Brown, Lemon Yellow or any colour with vermicular or any anti skid texture on top surface of approved pattern shape and colour having average crushing strength 40N/mm² manufactured in double layer precast concrete blocks. The top layer of paver block should be 12 to 15mm thick and consist cubical sharp stone aggregate 8mm size sieve 100% passing and retain on 4.75mm size sieve. The as and with pure iron oxide ultraviolet stabilized pigment @ 5% by weight of cement and should be coated with lacquer having hard, high abrasion resistance and water repellent. The bottom layer</p>							

9	RW-10.2K	Supply & filling sand, metal GRAVELLY SAND Correspondence to CLASS IV CLASS III GRADING of TABLE 100, of new road specifications-2006 in trenches upto required depth & watering, ramming etc. complete as directed	1.00	10.000	0.750	0.375	2.81
							Cum
10	RW-2-22	Rebate for not using motor grader & paver for laying of Granular Sub base in RW-2-21 Same as item no 4					1.90
							Cum
11	RW-10-60	Providing and fixing of the precast kerb stone of height 125mm, base width 165mm, top width 115mm in M20 grade RMC supplied through MCGM approved plant or concrete mixed with use of weigh batch mixers as detailed in drawing No.Dy.Ch.E/Rds/93 of S. of 17 / 8 / 2005, excavation in any soil except rock, laying a leveling course of M 15 grade RMC 100mm. thick, to required slope (inclusive of form work) jointing in 1:1:2 proportion flush to concrete surface, painting exposed surface with one coat of primer and two coats of 1st grade road marking paint in the yellow/white/black or any shade as directed. (Kerbstones shall be procured from MCGM (e.g. street agencies).	1	10.00			10.00
							Rmt.

- Note:
- 1) The sample estimate is as per unified schedule of rates effective from 16.09.2013
 - 2) Actual estimate shall however be prepared by adopting items and rates applicable as per prevailing contract of the reinstating agency.
 - 3) Payment for transportation of surplus earth will not be made separately to ward trench reinstatement contractor.
 - 4) For barricading, invariably the item RW-7-36 shall be opened

No: AMC/ES/ /II dated

ANNEXURE-II

SCHEDULE OF PENALTIES

Schedule of Penalties to be recovered from Utility/Ward Trenches contractor for various lapses observed during the excavation and reinstatement of trenches.

(A) For Utility and reinstatement contractor.

Sr No	Particulars	Penalty in Rs	Per
1	Delay in starting	5000	Day
2	Delay in Completion up-to 2 days	2500	Day
3	Delay in completion by more than 2 days and up-to 5 days.	5000	Day
4	Delay in Completion more than 5 days	10000	Day
5	Delay in completion phase wise.	2500	Day
6	Non-availability of Engineer in charge.	2500	Day
7	Non-fixing of Barricading	1000	Meter/Day
8	Not providing reflector signage	1000	Number
9	Non-Displaying board	2500	Number
10	Non-Appointing of warden	1000	Day
11	Not providing M.S. plate for crossing	5000	Day
12	Non-removal of excavated earth in time	5000	Day
13	Failing in removal of excavated earth	2500	Per Day
14	Non-covering of water entrance	1000	Each
15	Non-cleaning of water entrance	1000	Each
16	Damages to Municipal Utility	Actual cost	
17	Damages to other utilities	Actual Cost	
18	Damages to private property	Actual cost.	
19	Not providing night lighting	1000	Meter

(B) – For Utility Agency

Sr. No.	Particular.	Penalty in Rs.	Per
1	Increase in length than permitted	RI charges for excess length shall be recovered @ 1.5 times of the applicable RI charges	
2	Change in alignment Lump Sum.	25000	Lump sum
3	Change in Starting point	5000	Each
4	Change in end point	5000	Each
5	Even though alternative arrangement is established taking excavation under the guise of fault repairs.	25000	Each

(C) – For reinstatement contractor.

Sr. No.	Particular.	Penalty in Rs.	Per
1	Not rolling and compacting as per specification	2500	Meter
2	Delay in reinstatement of trench beyond end date	5000	Day
3	Not attending damaged trench during defect liability period; within 7 days from the date of reopening & reassignment of trench	5000	Day
4	Attending damaged trench through other Agency after 7 days during guarantee period.	Actual cost at his risk and cost.	

Note: Wherever unit is mentioned as meter it shall be taken with reference to length of trench.

MUNICIPAL CORPORATION OF GREATER MUMBAI

DETAILS OF BARRICADE FOR TRENCHES

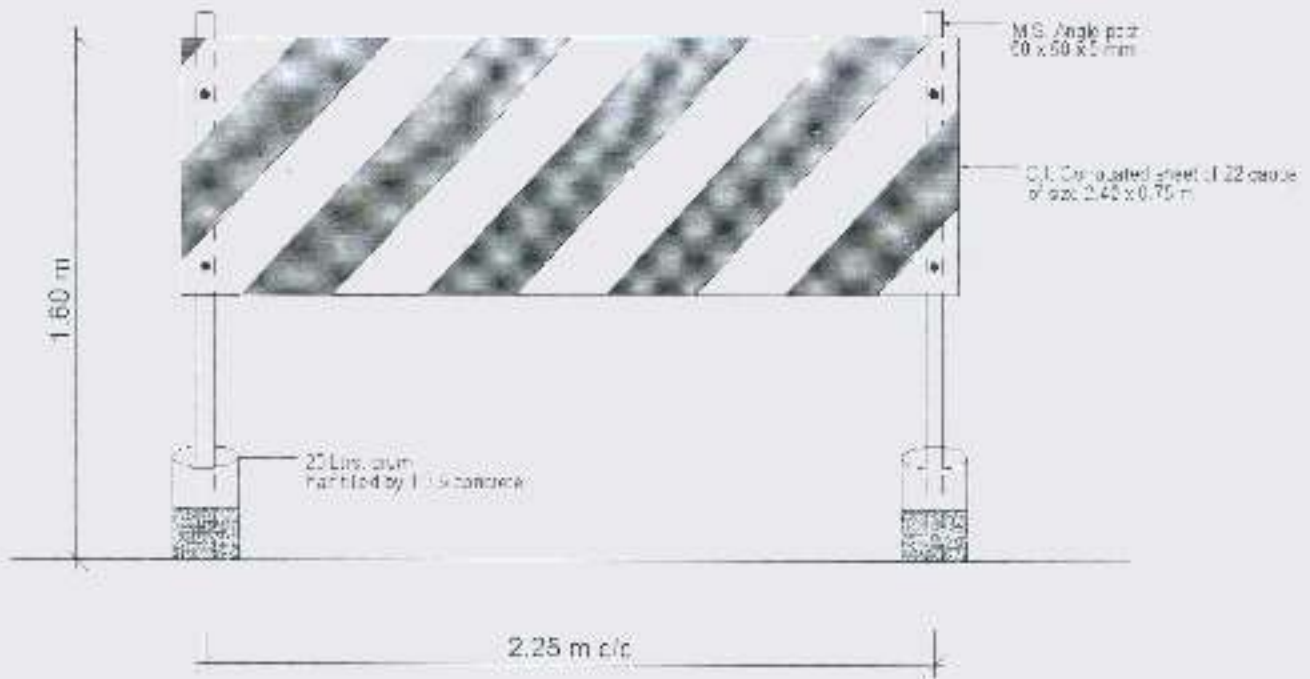

MUNICIPAL CORPORATION OF GREATER MUMBAI

DETAILS OF BARRICADE DURING EXCAVATION BY UTILITY

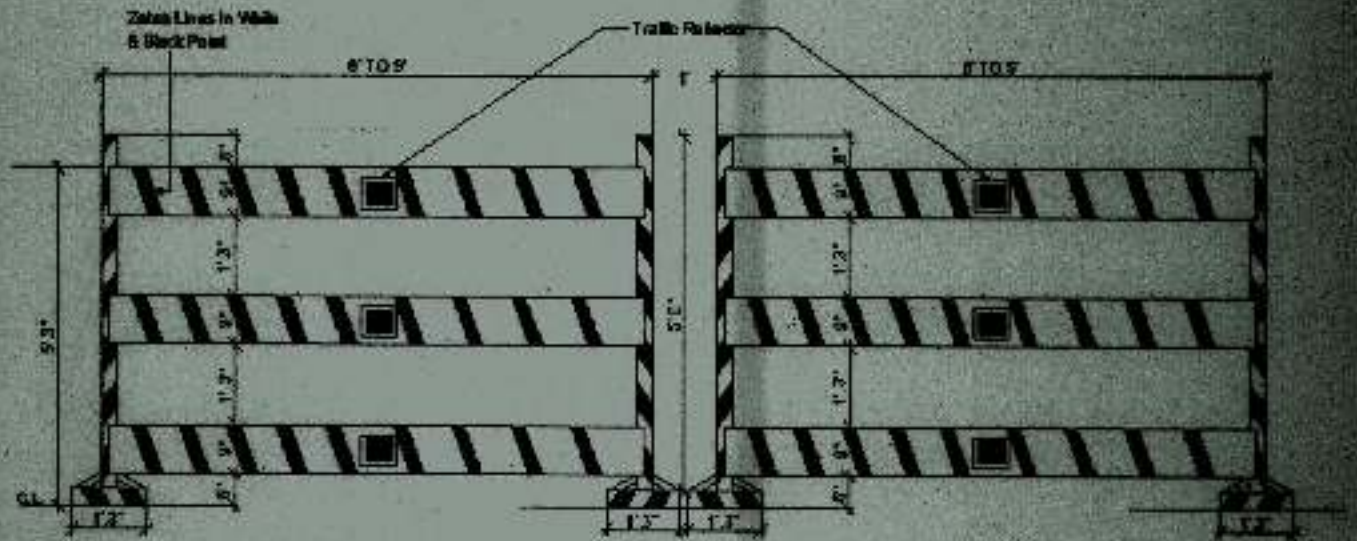

Barricade can be made from Steel or Wood

DETAILS OF DISPLAY BOARD

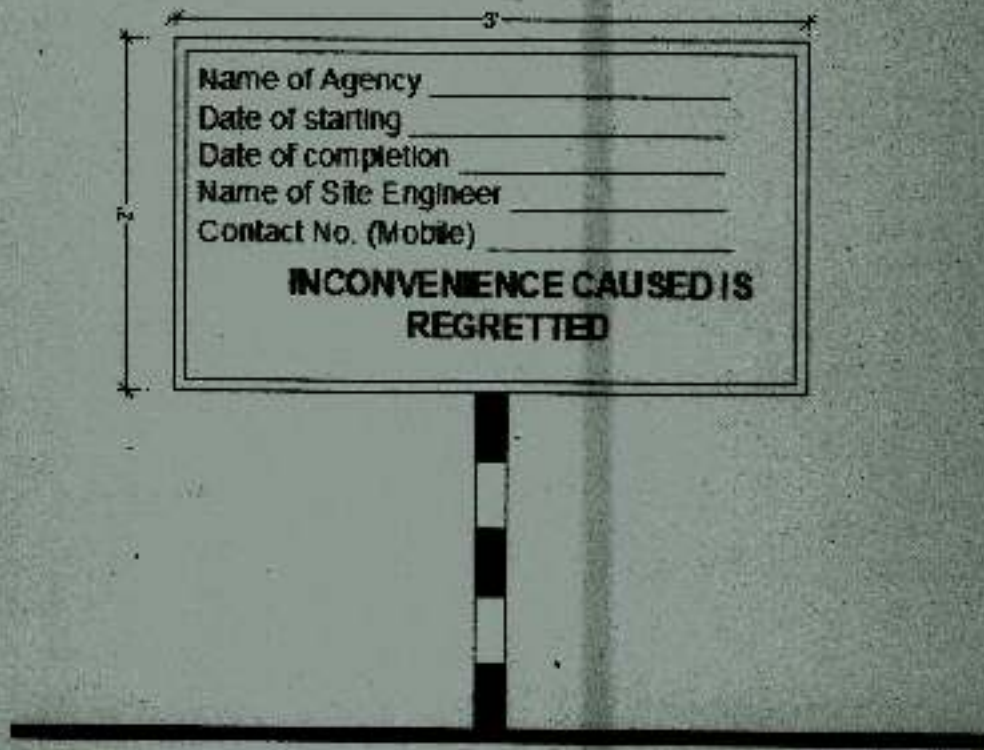

MUNICIPAL CORPORATION OF GREATER MUMBAI

No Dy. Ch.E. / 2752 / SWD/WS dtd. 1

AUG 2020

Subject Policy for Road side drains in Western and Eastern Suburbs.

The Storm Water Drains are constructed beneath the main carriageway for major portion in City Division. The road side storm water drains are constructed adjacent to the pedestrian footpaths but two feet below in Western and Eastern Suburbs. The drains are generally proportionate to the Road width, i.e. for road width of 60 feet, the width of the road side drains is 0.6m wide, and for road width of 90 feet, the width of the road side S.W.D is 0.9m wide, etc.

Majority all the roadside drains are covered with R.C.C slab to provide a pedestrian tread. Manhole covers are provided at regular intervals to enable cleaning of the drains. The cleaning of such minor drains is carried out through labourers.

It is observed that during cleaning of the roadside drains of 0.6m width or lesser width the labourers cannot reach their trowels/ cleaning tools beyond the region of manhole. Labourers cannot be permitted to crawl from chamber to chamber for such a small width as it can prove fatal. Hence the cleaning of minor drains having a width of 0.6m or lesser width and covered with RCC slab is very difficult. MCGM has taken up concretization of several roads, this has added to the run-off discharge in road side drains during monsoon.

In order to address the issues of advanced drainage, long term provision, cleaning issues and maintenance of the roadside drains, it is felt that an even policy for issue of S.W.D. remarks for a **minimum dimension** of the roadside drains is tabulated as 'Table A' below which should be given a serious thought and a general policy formulated.

Table A	
Road width	Minimum width
90 feet and below	900 mm ✓
above 90 feet	1200 mm

The depth shall be as per the invert level of upstream and downstream and gradient requirement. The depth shall be designed as per requirement of economical section. The drains shall be constructed in R.C.C as per the design approved by competent authority. The Manhole covers shall be placed at 5m c/c. Water entrances shall be provided at every 5m c/c.

In case where special consideration of drain design dimension is required as per site condition, any deviation from minimum dimension as tabulated 'Table A' above can be incorporated with approval of competent authority.

In view of above circumstances/facts, Ch.E (SWD)/ D.M.C (Infra)'s approval is requested for a general policy for S.W.D. remarks of minimum drain dimension of roadside drains as tabulated 'Table A' above for Western and Eastern Suburbs. *as well as for city.*

Submitted please

'A'

NBD
31/8/2020
Dy.Ch.E.(S.W.D), W.S

~~Ch.E.(S.W.D)~~

~~D.M.C.(Infra)~~
Sir,

Dy.Ch.E(SWD)PC
EE(SWD)PC(W.S)

pl. discuss & put up
urgently.

V. Dew
31/8/2020
Ch.E(SWD) etc

बृहन्मुंबई म. न. पा.	
प्रमुख अभियांता	
पर्यावरण व जलवाहिन्या	
दि.	02 SEP 2020
अनुक्र.	2333

Sir,

Discussed with planning cell.

'A' above be approved please

As proposed

A
3.9.2020

V. Dew
29/9/2020

[- 2 SEP 2020

Chief Engineer ±/C
Dy. Municipal Commissioner Storm Water Drains
(Infrastructure)

इहम्बई महानगरपालिका
उप आयुक्त (पायाभूत सुविधा)
यांचे कार्यालय

- 3 SEP 2020

SF

क्र. उप.आ./पा.सु./...2137

-3 SEP 2020

MUNICIPAL CORPORATION OF GREATER MUMBAI

Road Side drain Dimension check

There are various methods to calculate this viz. empirical / graphical method like dickens formula, rational method, SCS method.

We will adopt Rational method as it is suitable for small drainage area of up to 25 sq.km. This needs uniform critical rainfall intensity.

Now, $Q = 0.028 C_x A \times I$

A = Area in Hectares

I = Rainfall in (cm/hr)

P = Co-efficient of runoff

Q = Comecs

Now let us consider

Case

P = 0.9

Rainfall = I = 5 (cm/hr) (i.e. 50 mm/hr for Mumbai (IRC:50))

$V = (R^{2/3} \times S^{1/2}) / n$

V = Velocity = Permissible Velocity considered as scouring velocity

The range of self velocity is 0.6 m/s to 3 m/s as per Ministry of housing and urban affairs (Manual of storm water drainage – Volume-I, IRC-50 & IRC-42)

N = meaning coefficient rough

For concrete steel forms = 0.011

S = 1:500

R = Hydraulic Radius = $A = \frac{\text{Area}}$

P Wetted Perimeter

As per manning formula

$V = 1/n \times R^{2/3} \times S^{1/2}$

Now Considering Case -1 – for Road width below 90 feet

For Road with less than 90 feet

Assuming width = b=900 mm and depth = d=450 mm

Here R = 0.225

$V = (0.37 \times 0.0447) / 0.011 = 1.5 \text{ m/s}$

Since it is less than limiting velocity, hence O. K.

Now Considering Case -2 – for Road width above 90 feet

b= 1.2 m d = 0.6 m

R = 0.3

$V = (0.448 \times 0.0447) / 0.011 = 1.82 \text{ m/s}$, less than limiting value hence O.K.

Abhila
22/02/17

Rajul
ABK

MUNICIPAL CORPORATION OF GREATER MUMBAI

No. Ch.E. / 369 / SR / Rds & Tr. of 20 / 10 / 2021

- Subject:**
1. Stage-I Tenders of work codes E-265, E-266, E-272, E-268, E-267, AE-133, E-271, E-277, E-278, E-279, E-269, W-361, AW-207, AW-218, W-362, W-370, W-374, AW-205, AW-204, AW-222, W-364, W-375, W-377, W-367, W-382, AC-171, AC-172, AC-274, AC-275 from the department of Chief Engineer (Roads & Tr.)
 2. Stage-II Tenders of work codes C-287, C-292, C-282, C-288, C-289, C-281, C-285, C-283, C-286, C-276, C-280, AW-225, AW-197, AW-226, AW-227, AW-381, AW-224 and E-282 from the department of Chief Engineer (Roads & Tr.)
 3. Stage-III Tenders of work codes C-291, E-283, E-284, E-285, W-400, W-366, W-387 and W-379 from the department of Chief Engineer (Roads & Tr.)
- Reference:**
1. Pre-bid meetings held on 12.10.2021 and 18.10.2021
 2. Approval to stringent conditions of tender u/no.: MGC / VIP / 9612 dtd. 01.10.2021 (File-2 annexed in file board)
 3. Letter from the bidders represented in pre-bid meeting (File-3)

Recently, Roads department has invited the tenders for Stage-I, II and III with certain stringent conditions as approved by Hon'ble M.C. as per reference no-2 referred above. The tender notice for the stage-I, II and III tenders were published on 07.10.2021 and 12.10.2021 respectively.

The Pre-Bid Meetings for the above subjected tenders were held on 12.10.2021 and 18.10.2021 at 03.00 p.m. under the chairmanship of Chief Engineer (Roads & Tr.) / DMC (Infra.) at Conference Hall of the Office of the Ch.E.(Roads & Traffic), Municipal Engineering Hub, Ground Floor, Dr. E. Moses Road, Worli Naka, Worli, Mumbai – 400 018.

Attendance sheet of bidders is enclosed at page C/11-15 to C/59-58 Point wise clarification on the queries raised by the bidders & proposed modifications in the tender conditions (Minutes of Pre-bid Meeting) are attached at page C/17 to C/47 and C/59 to C/63.

It is to be stated that in proposed road work tenders of improvement in cement concrete, the quantity of Asphalt work is hardly 5 to 10 % of estimated cost. The

request of the bidders not to insist irrevocable registered undertaking cum declaration cum indemnity bond with Asphalt plant owner is considered and accordingly condition no. 6.7 B – Packet B d) 1) [I] is modified and enumerated in minutes of meeting at Sr. no. 12

Other proposed modifications in the Tender Conditions with respect to the queries raised in the pre-bid meeting by various bidders are as under:

Tender Clause no-2.2 of "Similar Work Experience" definition is modified as mentioned at sr. no. 4 at pg. C/ 22 to C/ 23.

Tender Clause no- 2.5 A of Ownership of Machinery and Equipment is modified and Assured Access for the Machinery & Equipment are allowed as mentioned at sr. no. 7 at pg. C/ 25 to C/ 27. Copy of the modified Annexure-H is attached at pg. C/ 65 and same will be uploaded on Portal and SRM System after approval of competent authority.

Tender Clause no- 6.8 of releasing Bid Security / EMD of the L2, L3 and so on is modified as mentioned at sr. no. 15 at pg. C/ 41 to C/ -.

Tender Clause no – 6.10 C of Performance Guarantee is modified as mentioned at sr. no. 18 at pg. C/ 43.

Tender Clause no – 6.10 D of releasing of Deferred Payment during DLP is modified as mentioned at sr. no. 19 at pg. C/ 43 to C/ 44.

Time schedule for submission of Packet A, B & C is revised for Stage-I tender as mentioned at sr. no. 6 of pre-bid dated 18.10.2021 at pg. C/ 63. Accordingly, date of submission of packet A, B & C for all stage-I, II and III tenders are on 03.11.2021 and Packet C to be opened on 18.11.2021.

In view of above facts, the Minutes of pre-bid meeting held on 12.10.2021 and 18.10.2021 are submitted herewith for perusal and approval please. On receipt of approval, the Minutes of Pre-bid Meeting of Stage-I, II and III tenders shall be uploaded on Portal and SRM Module with necessary corrigendum, if any.

Submitted for approval please.

~~AMC (Projects)~~

Hon'ble M.C.

Sr.

[Signature]
22/10/21
A. M. C. (P)

[Signature]
Ch.E.(Roads & Tr.) / D.M.C. (Infra.)

[Signature]
22/10-21
A.M.C. (P) M. C.

[Signature]
22/10/21
A. M. C. (P)

बृहन्मुंबई महानगर पालिका
 अतिरिक्त आयुक्त (प्रकल्प)
 यांचे कार्यालय

22 OCT 2021

क. अति.अ. / प्रकल्प / 5866

22/10/2021

बृहन्मुंबई महानगरपालिका
 अतिरिक्त आयुक्त
 एमजीसी उपविभाग

22 OCT 2021

दिनांक १०, ११, १२, १३, १४, १५,
 १६, १७, १८, १९, २०, २१

क्रमांक MGrC/F/5430

22/10/2021

NR

बृहन्मुंबई महानगर पालिका
 अतिरिक्त आयुक्त (प्रकल्प)
 यांचे कार्यालय

22 OCT 2021

क. अति.अ. / प्रकल्प / 5866

22-10-2021

DyChE(Roads) City/MS

PPF
 chb(Roads)

20/10/21

MUNICIPAL CORPORATION OF GREATER MUMBAI

Ch. Eng / /Roads & Traffic of / / 2021

Minutes of Prebid Meeting dated 12.10.2021 (Stage-I Tenders)

Sub.: E-Tenders for work codes E-265, E-266, E-272, E-268, E-267, AH-133, E-271, E-277, E-278, E-279, E-269, W-361, AW-207, AW-218, W-362, W-370, W-374, AW-205, AW-204, AW-222, W-364, W-375, W-377, W-367, W-382, AC-171, AC-172, C-274, C-275 from the department of Chief Engineer (Roads & Tr.)

Ref: Pre Bid meeting dated 12/10/2021 at 3:00 pm.

Pre bid meeting for the above mentioned tenders was called on 12.10.2021 in the Office of Ch.E.(Roads & Tr.) Gr. floor, MCGM Engineering Hub Bldg, Wadh-400018 at 3:00 PM, under the chairmanship of Ch.E.(Roads & Tr.) During the said pre-bid meeting, contractor's/ their representatives have raised queries and requested changes in a few tender clauses from the subject tenders.

The minutes of meeting are as under:

Sr No	Relevant Clause	Existing Tender Condition	Queries as raised by Contractor	Proposed modified tender condition.
1	Section-1	The application form can be downloaded from MCGM's portal (http://portal.mcg.gov.in) on payment of Rs.9400+ GST. The applicants not registered with MCGM are mandated to get registered (Vendor Registration) with MCGM for e-tendering process & obtain login credentials to participate in the online bidding process.	M/s R.D. Deora & Co. MCGM SAP website for e-tender has been revamped recently. And many bidders are still struggling to submit the tender in flawless manner. And MCGM is now available government's on Maharashtra e-portal https://mahatenders.gov.in , we request you to float these tenders https://mahatenders.gov.in , So on that transparency in tender process is ensured.	<u>Tender conditions prevail.</u>

Sr No	Relevant Clause	Existing Tender Condition	Queries as raised by Contractor	Proposed modified tender condition.
2	<p>2.0 Eligibility of Applicant</p>	<p>The Municipal Corporation of Greater Mumbai (MCGM) invites e-tender to appoint Contractor for the aforementioned work from contractors of repute, multidisciplinary engineering organizations i.e. eminent firm, Proprietary/ Partnership Firms/ Private Limited Companies/ Public Limited Companies/ Companies registered under the Indian companies' act 2013, the contractor to be registered with the Municipal Corporation of Greater Mumbai (MCGM) in Class (IA) and above (excluding those who are blacklisted or having HIR has been filed) or those having equivalent or more work experience from Central or State Government/Semi Government/Semi Govt. Organization/Central or State Public Sector Undertakings works, will be allowed subject to condition that, the contractors who are not registered with MCGM will have to apply for registering their firm with in three months from the date of issue of work order, otherwise security i.e. F.M.D (Earnest Money Deposit) will be forfeited/recovered and a penalty of 0.1% of</p>	<p>M/s QHPL, M/s R.D. Deora & Co., M/s D. B. Infraech</p> <p>As per e tender Notice and Eligibility of Applicants "The Municipal Corporation of Greater Mumbai (MCGM) invites e-tender to appoint Contractor for the aforementioned work from contractors of repute, multidisciplinary engineering organizations & eminent firm, Proprietary/Partnership Firms/ Private Limited Companies/ Public Limited Companies/ Companies registered under the Indian companies' act 2013, the contractors registered with the Municipal Corporation of Greater Mumbai, (MCGM) in Class (IA) and above (excluding those who are blacklisted or against whom HIR has been filed) or those having equivalent or more work experience from Central or State Government/Semi Govt. Organization/Central or State Public Sector Undertakings works, will be allowed. We request you to Consider it as (excluding those against</p>	<p>Tender conditions prevail.</p>

Sr No	Relevant Clause	Existing Tender Condition	Queries as raised by Contractor	Proposed modified tender condition.
		contract cost or Rs. 10,000/- whichever is more will be recovered/deducted from contractors payment/bill by existing department in M.C.G.M.	whom blacklisting order is ongoing as on date), as same was consider in MCGM tender for "Package IV: Diversion of Dry Weather Flow from Bapat Nalla and Safed Pul Nalla to Dharti WwTP through Tunnel.	
3	2.1 Technical Capacity	The financial year in which bids are invited will be considered as current financial year. The value of completed works shall be considered during last seven (7) financial years and up to date of submission of tender. a) Three similar completed works or currently executing three works of similar nature each costing 30% of estimated cost.* OR b) Two similar completed works or currently executing two works of similar nature each costing 40% of estimated cost.* OR One completed work or currently executing one work of similar nature of aggregate 60%	M/s. Ten Construction (India) Pvt Ltd, M/s. Ridhi Enterprises, M/s. JK Enterprises (Civil Engineers & Contractors), M/s. Yogesh Construction, M/s. Opera Infra Projects Pvt Ltd. M/s. Ten Construction (India) Pvt Ltd M/s Sahyog & Company M/s J.C.C Engineers M/s Pragati Enterprises M/s Supertech Construction Company Pvt. Ltd. M/s VNC Infraprojects, M/s R.D.Deora & Co. M/s Bharat Corporation, M/s. Prime Developers, M/s. Trans Conduct (India),	

Sr No	Relevant Clause	Existing Tender Condition	Queries as raised by Contractor	Proposed modified tender condition.
		<p>of estimated cost.*</p> <p>In case of ongoing works to be considered, the bidder must have received payment bills of 80% of the contract sum for the work/works executed last day of month previous to the one in which bids are invited.</p>	<p>M/s. Buecon Engineers & Infrastructure Pvt. Ltd.</p> <p>M/s. Mansi Constructions</p> <p>M/s. Yashi Construction</p> <p>M/s. Silhouette Infra projects</p> <p>M/s. Neufeld Constructions</p> <p>1. The modification suggested by contractors in brief are as below:</p> <p>a) Three similar completed works or currently executing three works of similar nature each costing 20% of estimated cost.*</p> <p>OR</p> <p>b) Two similar completed works or currently executing two works of similar nature each costing 25% of estimated cost.*</p> <p>OR</p> <p>One completed work or currently executing one work of similar nature of aggregate 40% of estimated cost.*</p>	<p>1. The modifications suggested by you are not accepted. Hence, <u>Tender conditions prevail.</u></p> <p>However, it is to clarify here that Financial Year 2021-22 is treated as current year. The value of executed works shall be brought to current costing level by enhancing the actual value of work at compound rate of 10% per annum; calculated from the date of completion to last date of receipt of</p>

C-24

Sr No	Relevant Clause	Existing Tender Condition	Queries as raised by Contractor	Proposed modified tender condition.
			<p>2. In case of ongoing works to be considered, the bidder must have received payment bills of 50% of the contract sum for the work/works executed last day of month previous to the one in which bids are invited.</p> <p>❖ In case of ongoing works, the works has been executed more than 80% but however due to unavailability of funds the contractor is not able to process the bills. Request you to kindly consider the works having progress more than 80% of the contract certified by the department. However, the amount of payment received shall be considered for the qualification.</p>	<p>applications for tenders (i.e enhancement will be applicable for year FY 2020-21 completing on 31st March 2021 and previous years therein).</p> <p>2. The modifications suggested by you for accepting 80% physical progress of works is not accepted. For considering ongoing works, 80% or more Financial Progress shall only be considered. Hence, <u>Tender conditions prevail.</u></p>

Sr No	Relevant Clause	Existing Tender Condition	Queries as raised by Contractor	Proposed modified tender condition.
4	2.2 <u>Similar Exp erience</u>	<p>“The ‘Similar Experience’ for Original and New work shall mean:-</p> <p>“The bidders should have carried out Road carriage way or Major Vehicular Bridges in CC Pavement / CC Passage/ TWT / UTWT in M40 and above or Asphalt Road in Asphalt Mix /Mastic Asphalt”</p>	<p>Queries as raised by Contractor</p> <p>M/s. Ten Construction (India) Pvt Ltd, M/s. Ridhi Enterprises, M/s. JK Enterprises (Civil Engineers & Contractors), M/s. Yogesh Construction, M/s. Opera Infra Projects Pvt Ltd. M/s. Ten Construction (India) Pvt Ltd M/s. Skyway Infraprojects Pvt. Ltd. M/s Chirag Corporation M/s Sahyog& Company M/s J.C.C Engineers, M/s Skyline, M/s VNC Infraprojects, M/s Buildwell Infrastructure Pvt Ltd. M/s. Silhouette Infraprojects. M/s. Neufeld Constructions</p> <p>The modification suggested by contractors in brief are as below:</p> <ul style="list-style-type: none"> • Similar Experience: For assessing the technical capacity of Regular, Routine and Maintenance works, Similar work shall mean, 	<p>The request is partially considered & condition is revised.</p> <p>“The bidders should have carried out Road carriage way</p>

Sr No.	Relevant Clause	Existing Tender Condition	Queries as raised by Contractor	Proposed modified tender condition.
			<p>the completed or ongoing works in Building Construction OR Building Maintenance such as repairs/retrofitting /structural repairs OR construction/repairs of Asphalt/ roads OR laying/rehabilitation of sewer lines along with allied components OR laying/rehabilitation of water pipe lines in Cast Iron/ M.S. pipes / HDPE/ MDPE pipes OR repairs/maintenance/ construction of culverts over nullah.</p> <ul style="list-style-type: none"> • Consider experience of works carried out in HE department. • Kindly allow laying of pipeline works as roads over the pipeline are made by the same contractor. Please clarify. 	<p>or Major Vehicular Bridges or inother works, full road carriageway width is developed, component of only road related works / items carried out in CC Pavement / CC Passage / TWT / UTWT in M40 and above or Asphalt Road in Asphalt Mix / Mastic Asphalt shall be considered". Certificate of concern engineer - in - charge mentioning that. Road works carried out to its full width and detailed cost of the road work, shall only be considered.</p>
5	<p>2.3 FinancialCapacity The turnover can be enhanced by 10% every year to bring the present level.</p>	<p>M/s Buildwell Infrastructure Pvt. Ltd. M/s. Prime Developers</p> <ul style="list-style-type: none"> • For financial Capacity, base year is not defined. 	<p>It is to clarify here that Financial Year 2021-22 is treated as current year. The value of executed works shall be brought to current costing level by enhancing the actual value</p>	

Sr No	Relevant Clause	Existing Tender Condition	Queries as raised by Contractor	Proposed modified tender condition.
6	2.4	<p>Bid Capaxity:</p> <p>Note: The statement showing the value of existing commitments and ongoing works as well as the stipulated period of completion remaining for each of the works listed should be attached along with certificates duly signed by the Engineer-in-Charge, not below the rank of an Executive Engineer or equivalent.</p>	<p>M/s R. D. Decorak Co.</p> <p>We want to bring your notice that at a time the contractors are having may work in hand in numerous numbers, and for each work in hand getting a certificate from client statement showing the value of existing commitments and ongoing works as well as the stipulated period of completion is very tedious and difficult. Hence, we request you to allow bidders to submit the work order copies along with statement showing the value of existing commitments and ongoing works as well as the stipulated period of completion remaining for each of the works signed and stamped by bidder's- chartered accountant on their letterhead.</p>	<p>of work at compound rate of 10 % per annum (i.e enhancement will be applicable for year FY 2020-21 completing on 31st March 2021 and previous years therein).</p> <p>Tender conditions prevail.</p>

C-28

Sr No	Relevant Clause	Existing Tender Condition	Queries as raised by Contractor	Proposed modified tender condition.
7	2.5 A	<p>Annexure-H Ownership of equipment and machineries, as per list attached in Annexure-H, shall be insisted for the contractual agencies with proper documentary evidence (i.e. in the name of agency) instead of assured access.</p>	<p>M/s. Kamala Construction Company, M/s. Shantinath Roadways Infrastructure Developer, M/s. New India Construction Co., M/s. A.I.C. Infrastructure, M/s. Opera Infra Projects Pvt. Ltd., M/s. Kamala Construction Company, M/s. Praveen Infra, M/s. Yogesh Construction, M/s. Ridhi Enterprises, M/s. Ten Construction (India) Pvt. Ltd., M/s D.B.Infratech, M/s. Skyway Infraprojects Pvt. Ltd, M/s Chirag Corporation, M/s M.B. Brothers, M/s Supertech Construction Company Pvt. Ltd., M/s VNC Infraprojects, M/s. Bharat Construction, M/s Yashraj Infrastructure, M/s Unnati Construction, M/s C P Construction, M/s. Acute Design, M/s Bharat Corporation, M/s. Prime Developers, M/s. D. B. Enterprise, M/s. Tanisha Enterprises, M/s. Trans Conduct (India)</p>	

Sr No	Relevant Clause	Existing Tender Condition	Queries as raised by Contractor	Proposed modified tender condition.
			<p>M/s. Bucon Engineers & Infrastructure Pvt. Ltd, M/s. Mansi Constructions M/s. Vishal Constructions M/s. Paras Infra M/s. Sagar Construction M/s. Gyan Construction M/s. Yashi Construction M/s. Silhouette Infraprojects. M/s. Newfield Constructions M/s. Track Civil Infra Pvt. Ltd.</p> <p>The modification suggested by contractor in brief are as below:</p> <ul style="list-style-type: none"> • Ownership of equipment machineries insisted should in lieu not and be an it undertaking on Rs.500/- stamp paper by way of lease/hire, should be insisted upon • Sir, most of the works are of improvement by concrete and TWT wherein Pneumatic roller is not required. Kindly accept the soil compactor instead of Pneumatic roller. • Four notices are invited under Chief Engineer Roads all require same set of machineries and as per clause if bidder has one set of 	<p>The request is considered & condition No-2.5 (A) is revised as under: The bidder shall upload the registered undertaking on Rs.500 stamped paper for assured access of Machinery and Equipments as listed in the modified Annexure-</p>

Sr No	Relevant Clause	Existing Tender Condition	Queries as raised by Contractor	Proposed modified tender condition.
8	6.2	<p><u>Contract Execution</u></p> <p>All required documents for execution of the contract shall be submitted within 30 days from the date of issue of letter of acceptance. 2% contract deposit shall be submitted in the form of Demand Draft only and shall not be released till the completion of Defect liability period. If the documents are not submitted within the stipulated time a penalty of Rs 5000/- per day will be applicable to the contractor. All contract documents need to be duly affixed with stamp duty properly signed along with evidence/proof of payment of security/contract deposit/ within 30 days from the date of letter of acceptance received by him.</p>	<p>machineries and have stood LI for 2 works they will be awarded only one work. Is this condition eligible for works under one notice or all works?</p> <p>M/s M.B. Brothers M/s VNC Infraprojects</p> <p>As the 20% payment already hold by MCGM till the end of DLP. The 2% contract deposit shall be in the form of FD. And shall be released after completion of work successfully.</p>	<p>II.</p> <p>The bidders request is not considered. Tender conditions prevail.</p>

Sr No	Relevant Clause	Existing Tender Condition	Queries as raised by Contractor	Proposed modified tender condition.
9	6.2	<p>Contract Execution</p> <p>All required documents for execution of the contract shall be submitted within 30 days from the date of issue of letter of acceptance. 2% contract deposit shall be submitted in the form of Demand Draft only and shall not be released till the completion of Defect liability period</p>	<p>M/s VNC Infra projects</p> <p>The condition of release of contract deposit contradicts the days after condition mentioned under clause 6.2 of Contract = DLP, 3rd Execution. Please Clarify</p>	<p>2% contract deposit shall be released only after the completion of Defect liability Period or Final Bill, whichever is later.</p> <p>This condition supersedes all other clauses mentioned in Tender with respect to CD refund.</p>
10	6.7 Packet B(4) Litigation History".	<p>Litigation History".</p> <p>If there is no Litigation History, the bidder shall specifically mention that there is no Litigation History against him as per the clause of Litigation History. In case there is Litigation History-</p> <p>Litigation History must cover-</p> <p>Any action Blacklisting, debarring, banning, suspension, deregistration and cheating with MCGM, State Govt., Central Govt., or any authority under State or Central Govt./Govt. organization initiated against</p>	<p>M/s QHPL</p> <p>M/s. Buceon Engineers & Infrastructure Pvt. Ltd.</p> <ul style="list-style-type: none"> Also as per clause 6.7 Submission of Tenders, B. Packet-B, point D) "Litigation History - Also, bidder shall disclose the litigation history of last 5 years from the date of submission of bid..." We request you to consider it as "Also, bidder shall disclose the ongoing litigation history of last 5 years from the date of submission of bid", as it was consider in MCGM tender 	<p>Tender conditions prevail.</p>

Sr No	Relevant Clause	Existing Tender Condition	Queries as raised by Contractor	Proposed modified tender condition.
		<p>company, firm, directors, partners or authorized signatory shall be disclosed for last 5 years from the date of submission of bid. Also, bidder shall disclose the litigation history of last 5 years from the date of submission of bid about any action like show cause issued, blacklisting, debarment, banning, suspension, deregistration and cheating with MCGM and MCGM is party in the litigation against the company, firm, directors, partners or authorized signatory for carrying out any work for MCGM by any authority of MCGM and the orders passed by the competent authority or by any Court where MCGM is a party. While taking decision on litigation history, the concerned Chief Engineer or D.M.C. or Director, as may be the case, should consider the details submitted by bidder and take decision based on the gravity of the litigation and the adverse effect of the act of company, firm, directors, partners or</p>	<p>for "Package IV: Diversion of Dry Weather Flow from Bapat Nalla and Safed Pul Nalla to Dharavi WwTF through Tunnel.</p> <ul style="list-style-type: none"> • Past blacklisted contractors who completed their sanctioned period should be allowed to participate in tender process. • Are debarred companies director/partner proprietor's family members companies considered for quoting the tender? 	

Sr No	Relevant Clause	Existing Tender Condition	Queries as raised by Contractor	Proposed modified tender condition.
11	6.7 Packet B b)	Annual financial turnover for preceding five financial years as certified by Chartered Accountant preceding the Financial Year in which bids are invited. Scan of Original of Applicants duly audited balance sheet and profit and loss account for the preceding five financial years (i.e 2020-21, 2019-20, 2018-19, 2017-18, 2016-17) (Proforma – II) unaudited balance sheet of previous two financial years 2020-21, 2019-20 will be permitted.	M/s Prime Developers Requesting not to insist for Audited Balance sheets of last year i.e. F.Y. 2020-2021 as the last date to file Audit Report 15.01.2022 & Audited Balance sheets by 15.02.2022. Hence, we request you to please allow Audited Balance Sheets for last five years i.e. from F.Y. 2015-16 to F.Y. 2019-20 and allow Provisional Profit & Loss & Balance Sheet certified by Chartered Account for the F.Y. 2020-21	Tender conditions prevail.
12	6.7 Packet B d) I] II]	ANNEXURE "G" (ARREVOOCABIE REGISTERED UNDERTAKING CUM DECLARATION CUM INDEMNITY BOND)	M/s AIC Infrastructure, M/s Ridhi Enterprises M/s Bharat Construction, M/s Supertech Construction Company Pvt. Ltd., M/s Apex Infra-Tech (P) Ltd, M/s Yashraj Infrastructure,	

Sr No	Relevant Clause	Existing Tender Condition	Queries as raised by Contractor	Proposed modified tender condition.
		<p>[1] For Cement-Concrete Road Works:- For C.C Road/C.C Passage/TWT/ UTWT works, it is mandatory that bidders should submit in Packet-B, the Registered Irrevocable Undertaking (U/T) cum Declaration cum Indemnity bond, in</p>	<p>M/s D.B. Infratech, M/s D.B. Enterprises, M/s Dev Engineers, Above 9 bidders raised following queries L. If a contractor owns "Batch Mix Asphalt Plant" but not registered with MCGM, he should be given sufficient time to get the same registered, if he is L-1 bidder.</p>	<p>1. The Tender Condition no - 6.7 B-Packet B, D [1] is modified as under: [1] <u>For cement concrete road works</u> For C.C Road/C.C Passage/TWT/ UTWT works, it is mandatory that bidders should submit in Packet-B, the Registered Irrevocable Undertaking (U/T) cum Declaration cum Indemnity bond, in prescribed format annexed in the Annexure - G, with MCGM registered RMC plant owner, regarding</p>

Sr No	Relevant Clause	Existing Tender Condition	Queries as raised by Contractor	Proposed modified tender condition.
		<p>prescribed format annexed in the Annexure -G, with MCGM registered (i) RMC plant owner, (ii) Asphalt plant owner who have arrangement for Mastic asphalt production regarding supply of materials as per MCGM specification.</p>	<p>2. We have installed an RMC plant and will obtain the MCGM registrations before execution, thus, kindly consider. As previously mentioned we will be providing an undertaking for the same.</p>	<p>supply of materials as per MCGM specification.</p> <p>2. The Tender Condition no - 6.7 B-Packet B, D [H] is modified as under: [I] <u>For cement concrete road works</u> For C.C Road/C.C Passage/TWT/ LTWT works, it is mandatory that bidders should submit in Packet-B, the Registered Irrevocable Undertaking (U/T) cum Declaration cum Indemnity bond, in prescribed format annexed in the Annexure - G, with MCGM registered RMC plant owner, regarding supply of materials as per MCGM specification.</p>

Sr No	Relevant Clause	Existing Tender Condition	Queries as raised by Contractor	Proposed modified tender condition.
			<p>M/s R.D. Deora & Co. M/s Verma Constructions Pvt. Ltd. Above: 2 bidders raised following query</p> <p>3. Wants a clarification whether the work (Page MOU with blacklisted contractor in MCGM, whose plant is registered with MCGM will be accepted or not.</p>	<p>3. Tender condition prevails. However, the clarification to the queries raised as under; As per the sanction u/a MGC/F/4205 dated 16.09.2017 / Supply of material and execution of road works are delinked. Road construction and running the plants are two separate issues. The plants which are not blacklisted by MCGM under registration with MCGM are eligible for issuing Registered Irrevocable Undertaking (U/I) cum Declaration cum Indemnity bond.</p>

Sr No	Relevant Clause	Existing Tender Condition	Queries as raised by Contractor	Proposed modified tender condition.
			<p>M/s Pankti Enterprise, M/s Opera Infra Project Pvt. Ltd., M/s Tanisha Enterprise, M/s Trans Conduci(India), M/s Mansi Construction, M/s Vishal Construction, M/s HV construction, M/s M.B. Brothers, M/s Riddhi Enterprises, M/s C.P. Construction, M/s Yogesh Construction, M/s Ten Construction (India) Pvt Ltd. M/s Pravin Infra, M/s Kamala Construction Company</p> <p>Above 14 bidders raised following query 4. To delete this clause.</p>	<p>4. The Tender Condition no <u>6.7 B-Packer B, D III</u> is modified as under: <input type="checkbox"/> For cement concrete road works For C.C Road/C.C Passage/TWT/ UTWT</p>

Sr No	Relevant Clause	Existing Tender Condition	Queries as raised by Contractor	Proposed modified tender condition.
			<p>M/s Buildwell Infrastructures Pvt. Ltd, M/s Chirag Corporation, M/s Ummati Construction, M/s Acute Designs, M/s Bharat Corporation, M/s Yashi Construction, M/s Silhouette Infra projects, M/s Neufeld Constructions, M/s Track Civil Infra Pvt Ltd,</p>	<p>works, it is mandatory that bidders should submit in Packet-B, the Registered Irrevocable Undertaking (U/T) cum Declaration cum Indemnity bond, in prescribed format annexed in the Annexure -G, with MCGM registered RMC plant owner, regarding supply of materials as per MCGM specification.</p>

Sr No	Relevant Clause	Existing Tender Condition	Proposed modified tender condition.
		<p>Queries as raised by Contractor</p> <p>M/s Rajaram Construction</p> <p>Above 10 bidders raised following query</p> <p>5. If the Tender BOQ Contains even no ASPHALT or MASTIC QTY or Less than 2% of the Estimate Amount, kindly do not mandate the Undertaking (U/T) cum Declaration cum Indemnity bond, in prescribed format annexed in the Annexure-G from, (ii) Asphalt plant owner who have arrangement for Mastic asphalt production.</p>	<p>5. The Tender Condition no - 6.7 B-Packet B, D III is modified as under</p> <p>II For cement concrete road works</p> <p>For C.C Road/C.C Passage/TWT/ UTWT works, it is mandatory that bidders should submit in Packet-B, the Registered Irrevocable Undertaking (U/T) cum Declaration cum Indemnity bond, in prescribed format annexed in the Annexure -G, with MCGM registered RMC plant owner, regarding supply of materials as per MCGM specification.</p>

Sr No	Relevant Clause	Existing Tender Condition	Queries as raised by Contractor	Proposed modified tender condition.
13	2.5 A (ii) and 6.7 Packet B (f)	<p>For Asphalt/ Mastic asphalt road/junction works, it is mandatory that bidder should submit in Packet-B, the Registered Irrevocable Undertaking (U/T) cum Declaration cum Indemnity bond, in prescribed format annexed in Annexure-G, with MCGM registered Asphalt plant owner who have arrangement for Mastic asphalt production regarding supply of materials as per MCGM specification for that work code only.</p>	<p>M/s D. B. Infratech,</p> <p>1. The tender clause 2.5, point no. 2 at page no. 11 to fix responsibility on plant owners. It is to also say that, for Asphalt/Mastic Road works, no undertaking cum indemnity bond has been asked from RMC Plant owner which should have been asked as in any road works, SWD works are included and are to be casted in concrete only.</p>	<p>1. The condition 2.5 pt. 2 is modified as under:</p> <p>For Asphalt/ Mastic asphalt road/junction works, it is mandatory that bidder should submit in Packet-B, the Registered Irrevocable Undertaking (U/T) cum Declaration cum Indemnity bond, in prescribed format annexed in Annexure-G, with MCGM registered (f) RMC Plant Owner (f) Asphalt plant owner who have arrangement for Mastic asphalt production regarding supply of materials as per MCGM specification for that work code only.</p>

Sr No	Relevant Clause	Existing Tender Condition	Queries as raised by Contractor	Proposed modified tender condition.
			<p>M/s Dev Engineers,</p> <p>2. However, there are few MCGM registered plants available in the market and it is very difficult to obtain the undertaking/MOU with the plants owner. It is clear chance of creating the monopoly by the plants owner and they will not do the Undertaking/MOU with us to reduce the competition in the bidding process. We have been executing the roads work with MCGM from last 15 years and we are the reputed MCGM registered contractor and also having two owned R.M.C plants, but we don't have the asphalt plant having arrangement for mastic asphalt production. Vide this letter we are here with requesting your good self to consider the submission of the above said Undertaking / MOU within 7 days after receiving the L.O.A from M.C.G.M., we will assure you that if we are the L-1 bidder and after receiving the L.O.A. from MCGM we will establish our own plant or</p>	<p>2. <u>Tender conditions prevail.</u></p>

Sr No	Relevant Clause	Existing Tender Condition	Queries as raised by Contractor	Proposed modified tender condition.
14	6.7 Packet A& B Note	Maximum two (2) shortfalls will be allowed for curable defects. For more than two (2) nos. of shortfalls, 2% of EMD will be forfeited for each shortfall thereafter. This shall be in addition to any forfeiture of proportionate EMD for curable defects as per other relevant clauses of the tender document, if applicable	<p>submit the undertaking/MOU with the MCGM reversed plant owner within 7 days. If we are fails to submit the same M.C.C.M.E will take the appropriate action on us as per the tender condition.</p> <p>M/s. Kamala Construction Company, M/s. Praveen Infra, M/s Superitech Construction Company Pvt. Ltd., M/s VNC Infraprojects, M/s Ummati Construction, M/s R. D. Deora & Co., M/s. Trans Conduct (India), M/s. Bucon Engineers & Infrastructure Pvt. Ltd.</p> <p>The modification suggested by contractor</p> <ul style="list-style-type: none"> As the SRM 7.0 system is new and many documents are to be uploaded and the files size has to be small hence many documents can be unclear and might result in shortfall 2) This kind of system is not followed in any other Government department and will discourage the bidders to quote for more 	
			<p>Tender conditions prevail. However, such shortfalls shall be considered on merits by concerned respective Dy.Ch.E.(Roads) at the time of bid scrutiny & his decision will be</p>	

Sr No	Relevant Clause	Existing Tender Condition	Queries as raised by Contractor	Proposed modified tender condition.
			<p>tenders thereby reducing open, fair competition. As per SBD the bidders are allowed to make suggestions for fair, transparent & competitive bidding process</p> <ul style="list-style-type: none"> • Shortfall in case of corrupt file should not be considered as this is software related issue. • This condition of forfeiture of EMD of 2% is outright rubbish and outright unjustifiable. We want to bring in your notice that there are many departments who does not ask for any shortfall document after submission and they outrightly reject the tender if certain criteria are not fulfilled and there are other department who if they deem fit, asks for submission of shortfall documents. In no department there is a provision of deducting EMD for non-submission of shortfall documents. Hence MCGM should either scrutinized the document only on the basis of documents submitted or they should to submit the shortfall documents as they may 	<p>treated as final tender condition.</p>

Sr No	Relevant Clause	Existing Tender Condition	Queries as raised by Contractor	Proposed modified tender condition.
15	6.8	The tenderers shall pay the EMD and ASD online instead paying the EMD & ASD at any of the CFC centers in MCGM Ward Offices.	<p>deem fit and should not have a provision of forfeiture of EMD whatsoever. Hence this condition should be deleted.</p> <p>M/s. Kamala Construction Company, M/s Supertech Construction Company Pvt. Ltd.</p> <p>M/s. Bucon Engineers & Infrastructure Pvt. Ltd.</p> <p>The modification suggested by contractor in brief are as below: Earlier EMD is not refunded and other issues related it</p>	
16	6.8	<p>BID SECURITY OR EMD</p> <ul style="list-style-type: none"> The Bid Security/ EMD of L-3 and bidder shall be refunded immediately after opening of financial bid but, the EMD/ASD submitted by the L-2 bidder will be returned after obtaining Standing Committee Resolution. In case, the successful bidder becomes non-responsive or successful bidder withdraws the bid or is unwilling to extend the bid validity period, in such circumstances, if L-2 bidder is agreeable to extend the bid validity period and ready to deposit the requisite amount of bid 	<p>M/s VNC Infraprojects</p> <p>M/s Bucon Engineers & Infrastructure Pvt. Ltd.</p> <p>Kindly refund the Bid Security / EMD of L-2 tenderer immediately as per tender opening of financial bid as per prevailing policy of MCGM. All other department in MCGM are releasing the EMD of L2 tenderer immediately after opening of financial bid</p>	<p>Tender conditions prevail.</p> <p>The request of the bidder is not considered, however, condition no- 6.8 is modified as under: After the finalization of the successful lowest bidder for the work, EMD of the other</p>

Sr No	Relevant Clause	Existing Tender Condition	Queries as raised by Contractor	Proposed modified tender condition.
17	6.10 A Security Deposit	<p>security/ EMD and ASD to the department within the stipulated time period i.e. 15days, the department will process further as per normal procedure.</p> <p>D Contract Deposit -</p> <p>The successful tender, here after referred to as the contractor shall pay an amount equal to two (2) percent of the contract sum in shall be paid within thirty days from the date of issue of letter of acceptance. The said Contract Deposit will be paid in form of Demand Draft (D.D.) only.</p>	<p>M/s. Shantinath Roadways Infrastructure Developer, M/s. New India Construction Co., M/s. Opera Infra Projects Pvt Ltd M/s. Yogesh Construction M/s. Ridhi Enterprises M/s. Ten Construction (India) Pvt Ltd M/s Pragati Enterprises M/s Supertech Construction Company Pvt. Ltd. M/s Kailash Construction, M/s VNC Infraprojects, M/s R.D.Decor& CO., M/s. Acute Design, M/s Bharat Corporation, M/s. Buceon Engineers & Infrastructure Pvt. Ltd. M/s. Gyan Construction</p> <p>The modification suggested by contractor in brief are as below: Successful bidder required to pay 2% contract</p>	<p>bidders shall be released within 30 days, on merits.</p> <p>Tender conditions prevail.</p>

Sr No	Relevant Clause	Existing Tender Condition	Queries as raised by Contractor	Proposed modified tender condition.						
18	6.10 C Performan ce Guarantee	<table border="1"> <thead> <tr> <th data-bbox="552 1532 584 1778">Offer</th> <th data-bbox="552 1144 584 1532">PG applicable %</th> </tr> </thead> <tbody> <tr> <td data-bbox="592 1532 767 1778">For premium, at par and rebate upto 12%</td> <td data-bbox="592 1144 767 1532">PG = 0.92% x contract sum applicable for rebate of 12%</td> </tr> <tr> <td data-bbox="775 1532 1031 1778">For rebate of 12.01% and above</td> <td data-bbox="775 1144 1031 1532">P.G. = {0.92% x contract sum applicable for rebate of 12%} + (X) x contract sum where X = percentage rebate quoted more than 12%</td> </tr> </tbody> </table>	Offer	PG applicable %	For premium, at par and rebate upto 12%	PG = 0.92% x contract sum applicable for rebate of 12%	For rebate of 12.01% and above	P.G. = {0.92% x contract sum applicable for rebate of 12%} + (X) x contract sum where X = percentage rebate quoted more than 12%	<p>deposit in form of Demand Draft. This condition will have adverse impact on cash flow of the contractor and should be replaced by Bank Guarantee as was being done here to before.</p> <p>M/s. Shantinath Roadways Infrastructure Developer, M/s. New India Construction Co., M/s. Opera Infra Projects Pvt Ltd M/s. Yogesh Construction M/s. Ridhi Enterprises M/s. Ten Construction (India) Pvt Ltd M/s Chirag Corporation M/s M.B. Brothers M/s Pragati Enterprises M/s. Acute Design M/s Bharat Corporation</p> <p>The modification suggested by contractor is brief are as below:</p> <p>As the 80.20 % condition is incorporated, not to insist for PG applicable %</p>	
Offer	PG applicable %									
For premium, at par and rebate upto 12%	PG = 0.92% x contract sum applicable for rebate of 12%									
For rebate of 12.01% and above	P.G. = {0.92% x contract sum applicable for rebate of 12%} + (X) x contract sum where X = percentage rebate quoted more than 12%									
19	6.10 D Deferred Payment	<p>b) For C.C Roads with 10 years DLP: i) 20% withheld amount will be released as under - 4% will be released each year from the completion of 6th year of the DLP till the</p>	<p>The request of the bidder is considered, hence, the performance guarantee shall not be insisted and Clause No-6.10 'C' is to be treated as "DELETED".</p> <p>The bidders request is partially considered, hence, clause no- 6.10 D 1 b (i) for 10years DLPs</p>							

Sr No	Relevant Clause	Existing Tender Condition	Queries as raised by Contractor	Proposed modified tender condition.
20	10.22	<p>completion of DLP or after Final Bill whichever is later.</p> <p>e) For C.C Passage /Roads & Junctions in Mastic and other roads with 5 years DLP @ 20% withheld amount will be released as under - For 5 years DLP Roads 6 % payment will be released each year on completion of 3rd and 4th years of DLP and 8% will be released on the completion of 5th year of DLP or after Final Bill whichever is later</p>	<p>M/s. Ridhi Enterprises M/s. Ten Construction (India) Pvt Ltd M/s Chirag Corporation M/s Pragati Enterprises M/s VNC Infaprojects M/s. Bucon Engineers& Infrastructure Pvt. Ltd M/s. H.V.Construction M/s. Sagar Construction M/s. Gyan Construction M/s. Silhouette Infaprojects, M/s. Neufeld Constructions</p> <p>For differed payment of 80:20 ratios, consider disbursement of payment during DLP year-wise</p> <p>M/s Supertech Construction Company Pvt. Ltd. M/s R.I.Brothers M/s. Sai Enterprises M/s. Bucon Engineers & Infrastructure Pvt Ltd M/s. Gyan Construction</p> <p>Kindly consider a 10% price variation as variation is restricted current market is very volatile and</p>	<p>modified as under: 1. 20% Deferred payment shall be released after completion of work / submission of Final Bill, whichever is later, @ 2% every year for 10yrs of DLP. However, for clause no - 6.10 D 1 c (i) for 5years DLP and clause no - 6.10 D 1 d (i) for 3years DLP, there is no change in tender condition.</p> <p><u>Tender conditions prevail.</u></p>

Sr No	Relevant Clause	Existing Tender Condition	Queries as raised by Contractor	Proposed modified tender condition.
21	10.85	<p>Subletting:- Subletting of work will not be allowed for this tender as per circular no. Ch.E./248/SR/Rds& T. Dated 05.08.2019.</p>	<p>prone to inflation in price of goods & services. Due to this there are many chances that cost escalation may increase.</p> <p>M/s Chirag Corporation</p> <p>As MCGM is not allowing sublet and new started only Similar work experience, MCGM will never have fair competition and only selected list of bidders will bid for works every time in upcoming time, and no other bidders will be ever be able to even think of bidding road works. I would like request you to kindly allow subletting for the works.</p>	
22	<p>ANNEXURE "A" DEFECT LIABILITY PERIOD</p>	<p>1.) For Cement Concrete road work having thickness 280 mm and above: 10 years ...</p>	<p>M/s. Shantinath Roadways Infrastructure Developer, M/s. New India Construction Co. M/s VNC Infraprojects M/s. Sagar Construction</p> <p>The modification suggested by contractor in brief are as below: The contractors are required to undertake work in accordance with the norms prescribed by the MORTH. Therefore the DLP period should also</p>	<p>Tender conditions prevail.</p>

Sr No	Relevant Clause	Existing Tender Condition	Queries as raised by Contractor	Proposed modified tender condition.
23	ANNEXU RE "D"	Rate Analysis	<p>be as per MORTI norms i.e. 5 years and not 10 years</p> <p>M/s VNC Infraprojects</p> <p>As per Annexure D sample format for item R2-RW 10.33 is given. During study it is seen certain fixed quantities are mentioned in the format. In case, if these types of quantities are fixed for all BOQ items, we request you to provide the format for all items included in Bill of Quantities.</p>	<p>Guidelines for the same shall be intimated to the L1 and T2 bidders through eMail at the time of demanding Rate Analysis.</p>
24	Section 16	Circulars	<p>M/s VNC Infraprojects</p> <ul style="list-style-type: none"> • Circulars not available 	<p>Not accepted. Circulars are already uploaded in SRM along with Bid documents.</p>
25	General Points		<p>M/s R.L. Brodiers</p> <ul style="list-style-type: none"> • Fund availability issue, Assurance for billing in 15 days after filing of Bill. • Mobilisation advance of 10% should be issued. 	<ul style="list-style-type: none"> • Not related to Tender Conditions. • Not accepted.
26	General		<p>M/s G.L. Construction</p>	<p>Request not considered. Contractor shall quote</p>

Sr No	Relevant Clause	Existing Tender Condition	Queries as raised by Contractor	Proposed modified tender condition.
	Points		<ul style="list-style-type: none"> 12% GST should be paid extra. 	accordingly.
27	General Points		<p>M/s VNC Infraprojects It can be seen from Annexure 'A' of the tender document that the DLP of work varies for ancillary types of work. In particular case of 5 years and 10 years DLP certain work DLP is only 3 years. So, after completion of DLP of 3 years if the work is to be maintain certain cost provision shall be done for maintenance of work. So, I request you to kindly do provision within the tender documents for maintaining the part of work wherein DLP gets over before the completion of DLP of entire road.</p>	<p>Tender conditions prevail.</p>

[Signature]
Dy. Ch.E. (Roads) W.S.
25/11/2010

[Signature]
Dy. Ch.E. (Roads) E.S.

[Signature]
Dy. Ch.E. (Roads) City

[Signature]
Ch.E. (Roads & Traffic) / DMC (Infra.)

Minutes of Prebid Meeting dated 18.10.2021 (Stage-II and III Tenders)

- Sub.:**
- 1) E-Tenders for work codes C-287, C-292, C-282, C-288, C-289, C-281, C-285, C-283, C-286, C-276, C-280, AW-225, AW-197, AW-226, AW-227, W-381, AW-224 and E-282 from the department of Chief Engineer (Roads & Tr.)
 - 2) E-Tenders for work codes C-291, E-283, E-284, E-285, W-400, W-366, W-387 and W-379 from the department of Chief Engineer (Roads & Tr.)

Ref.: Pre Bid meeting dated 18/10/2021 at 3:00 pm.

Pre bid meeting for the above mentioned tenders was called on 18.10.2021 in the Office of Ch.E.(Roads & Tr.) Gr. floor, MCGM Engineering Hub Bldg, Work-400/18 at 3:00 PM, under the chairmanship of Ch.E.(Roads & Tr.). During the said pre-bid meeting, contractor(s) / their representatives have raised same queries as raise in the pre-bid meeting held on 12.10.2021 and suggested new changes in a few tender clauses from the above subject tenders.

The minutes of meeting are as under:

Sr. No	Relevant Clause	Existing Tender Condition	Queries as raised by Contractor	Proposed modified tender condition.
1	2.2 Similar Experience	"The 'Similar Experience' for 'Original and New work' shall mean:- "The bidders should have carried out Road carriage way or Major Vehicular Bridges in CC Pavement / CC Passage / TWT / UTWT in M40 and above or Asphalt Road in Asphalt Mix / Mastic Asphalt"	M/s Sahyog & Co., M/s Ranuja Dev Corporation, M/s Rajaram Construction, Definition of Similar Experience for "Original and New Work" shall be maintained / kept as per SBD.	Request of the bidder is not considered, however, the modified condition of 2.2 Similar Experience is as under: "The bidders should have carried out Road carriage way

Sr. No	Relevant Clause	Existing Tender Condition	Queries as raised by Contractor	Proposed modified tender condition.
2	6.7 Packet A & B	All Declarations / Undertakings / Annexures / Proforma's / Registered Irrevocable Undertaking cum Declaration cum Indemnity Bond shall be given separately for the individual Tenders.	M/s M. E. Infraprojects, M/s VNC Infraprojects, M/s Gyan Construction, M/s Chirag Corporation M/s R. D. Deora& CO., M/s Unnat Construction, M/s Paras Infra M/s Kamala Construction Company,	or Major Vehicular Bridges or in other works, full road carriageway width is developed, component of only road related works / items carried out in CC Pavement / CC Passage / TWT / UTWT in M40 and above or Asphalt Road in Asphalt Mix / Mastic Asphalt shall be considered. Certificate of concern engineer – in – charge mentioning that, Road works carried out to its full width and detailed cost of the road work, shall only be considered.

Sl. No	Relevant Clause	Existing Tender Condition	Queries as raised by Contractor	Proposed modified tender condition.
3	2.5A	<p>Annexure-H Ownership of equipment and machineries, as per list attached in Annexure-H, shall be insisted for the contractual agencies with proper documentary evidence (i.e. in the name of agency) instead of assured access.</p>	<p>To allow uploading of all documents in SRM System in the highest bid amongst the recently invited Tenders of Roads Department and in other bids acknowledgement receipt of the uploading of all documents in highest tender will be uploaded.</p> <p>M/s Rupesh Construction, M/s Unnati Construction, M/s Rajaram Construction, M/s Sun Infra Projects,</p> <p>1. Ownership of Machinery clause shall be revised and reduce the number of machineries required for tender on ownership basis.</p>	<p>Request of the bidder is not considered.</p> <p>Tender Conditions Prevail.</p>
			<p>1. The request is considered & condition No - 2.5 A is revised as under: The bidder shall upload the registered undertaking on Rs.500 stamped paper for assured access of Machinery and Equipments as listed in the modified Annexure-H.</p>	

Sr. No	Relevant Clause	Existing Tender Condition	Queries as raised by Contractor			Proposed modified tender condition.
4	6.7 Packet B (d)	In case of otherwise eligible bidders who have not complied with the submission of Irrevocable Undertaking cum Declaration cum Indemnity bond in Packet-B. (Non-submission of said Undertaking will not be considered as a Shortfall) and they all will be allowed to submit the same within seven days from the opening of Packet-C. However, failure to submit within seven days will be treated as non-curable defect and the bidders EMD will be forfeited.	M/s M. B. Infra projects, We request you to provide us time of atleast 3-4 months to fulfil / comply the tender condition.			Request of the bidder is not considered. <u>Tender Conditions</u> <u>Prevail</u>
5	6.7 Packet B (j)	ANNEXURE "G" (IRREVOCABLE REGISTERED UNDERTAKING CUM DECLARATION CUM INDEMNITY BOND)	M/s Sun Infra Projects, M/s M. B. Infra projects, In case we don't have the MoU with plant, please allow B.G for Plant as previously allowed in MCCGM Tenders			Request of the bidder is not considered. <u>Tender Conditions</u> <u>Prevail</u>

Sr. No	Relevant Clause	Existing Tender Condition	Queries as raised by Contractor	Proposed modified tender condition.
6	General Condition		<p>M/s Rupesh Construction, M/s M. E. Infraprojects, M/s VNC Infraprojects, Due to Diwali Festival & Covid-19, it is difficult to study and submit the bids by 28.10.2021 (i.e. tenders published on 07.10.2021). So kindly extend the date of submission atleast by 15 days and also requested to keep the date of Packet A, B & C online submission, same for all the tenders.</p>	<p>Request is partially considered. For all tenders whose sale were started from 07.10.2021 and 12.10.2021 in Roads Department, the revised schedule of dates and time for submission and opening of the e-Packets A, B and C are as tabulated below:</p>

Last date & Time of sale of e-tender for all subjected Tenders	Submission of Packet 'A', 'B' and 'C' (online)	Opening of e-packets	
03.11.2021 Upto 12:00hrs	03.11.2021 Upto 16:00hrs	e-Packet 'A' 03.11.2021 16:15hrs onwards	e-Packet 'B' 03.11.2021 16:20hrs onwards
			e-Packet 'C' 18.11.2021 11:00hrs onwards

Gurpreet Singh
Dy.Ch.E.(Roads) E.S.

H. S. Singh
20/11/21
Dy.Ch.E.(Roads) City

H. F. (Roads & Traffic) / DMC (Infra.)

Dy.Ch.E.(Roads) W.S.

Ch.E. (Roads & Traffic) / DMC (Infra.)

MUNICIPAL CORPORATION OF GREATER MUMBAI

CIRCULAR

U/No.MGC/F/6342 dated 5.5.2018

Sub.: Revised guidelines regarding barricades being used during the execution of various infrastructure development projects by MCGM in Mumbai.

Various infrastructure development projects are being executed by MCGM for the betterment of citizens of Mumbai. During the course of execution of the projects, it is necessary to provide strong and secured barricading as a safety measure to avoid any mishaps as well as to avoid nuisance to vehicular and pedestrian traffic. Nowadays, the following types of barricades are being used exclusively in MCGM as per the convenience of various departments at different sites.

1. Water/sand fillable PVC Metro barricades.
2. RW 7.45 (G.I. sheets of 22 gauge fixed on 3 inch dia. Wooden bullies buried in existing road sufficiently)
3. RW 7.36 (G.I. sheets of 22 gauge fixed on MS Angle post buried in half the depth in drums of 20 litres capacity in 1:3:6 concrete)
4. Structural steel barricade for major trenches having depth more than 2.00 meters.

Thus from the above, it can be seen that there is no uniformity in provision of barricades as they are of different size and shape. Further it is also observed that the continuity is not maintained in providing the barricading keeping gaps in between thus endangering the safety of vehicular as well as pedestrian traffic. Also the barricades are not being cleaned, thus further adding to shabbiness. Further Mumbai being the financial capital of India, people from all over the world visit the city daily and to maintain good image of city the following decisions are taken.

- A) Only two type of barricades having department wise colour coding are proposed to be used depending upon the nature of work i.e. Minor and Major.
- i) **Minor works:** Barricading made out of 1.5 mm thick MS plate fixed on M.S. angle post/ frame of 65 mm X 65 mm X 6 mm having height of 1.5 m supported on as shown in Annex-I.
 - ii) **Major works:** Structural steel barricade made out of 1.50 mm thick M.S. Plate ISMB 250, ISLC 250X50mm and ISA 50mmX50mmX6 mm having of size 2.5 m X 2 m as shown in Annex-II.
- B) The department wise colour coding for the barricading shall be as under:-
- i) H.E. & W.S.P. department – **Blue**
 - ii) Roads, Traffic, Bridges and Coastal Roads department– **Yellow**
 - iii) S.P. & S.O department – **Green**
 - iv) S.W.D., Building Maintenance department & for ward works – **Red**
- C) The basic principle behind installing secured and continuous barricading is to ensure the safety of vehicular as well as pedestrian traffic and residents in the nearby vicinity of the project. Due to non-installation of appropriate barricades on sites if any mishap occurs leading to injury or loss of life, then the contractor and contractor's Engineer in-charge will be liable for the consequent action.
- D) During the course of execution of project, if it is noticed that the contractor has not provided barricading then a penalty of Rs.1000/- per meter per day will be imposed upon the contractor and will be deducted from the due Bill. This penalty shall be a part of penalty as per tender condition.
- E) Details of the work shall be prominently displayed on the central panel of the barricades along-with the Social Slogans as given in Annexure III and the Cycle of the same shall be maintained.
- F) The contractor shall provide and install the barricading alongwith the slogans printed as per the Annexure III, at his own cost and no payment will be made for this, however the contractor shall quote the bid accordingly by considering the cost of barricading.

The condition shall be included in the tender as given below. “
Barricading shall be provided free of cost as per Circular vide U/No.MGC/F/6342 dated 5.5.2018 and as per Annexure I, II and III of Standard drawings and specifications with slogans and department wise colour codes.” The copy of circular will be attached to the tender as a part of tender document.

This circular will be applicable for the new tenders proposed to be invited from 01.05.2018 and also the corrigendum shall be attached to tenders which are uploaded. However, for the projects wherein the tenders are already invited, the barricading shall be provided strictly as per tender condition. All the details (Annexure I, II & III of Standard drawings and specifications with slogans and department wise colour codes, sketches and department wise colour coding) are uploaded on MCGM portal.

This circular shall come in force with immediate effect.

sd/- 20.4.2018
(Shri V.P . Chithore)
Dir.(ES&P)

sd/- 20.4.2018
(Shri R. B. Bambale)
D.M.C.(S.E.)

sd/- 21.4.2018
(Shri Vijay Singhal)
A.M.C.(E.S.)

sd/- 21.4.2018
(Dr. Shri Sanjay Mukherjee)
A.M.C.(P.)

sd/- 5.5.2018
(Shri Ajoy Mehta)
M. C.

sd/-16.5.2018
(Shri P. R. Kadam)
D.M.C.(S.E.)

ANNEXURE I

A) Minor work

Providing, fabricating and installing the barricading made out of 1.5 m high M.S. Angle post of 65 mm X 65 mm X 6 mm with 1.5 mm thick M.S. Sheet of size 1.55 m X 1.2 m welded to the M.S. angle post/ frames and fixed to 75mm X 75mm X 6 mm angle base as shown in sketch for minor works , displaying of the social slogan as per the Annex - III, daily cleaning of the same to get better appearance and interlocking arrangement to ensure continuity in provision and to avoid gap in between etc complete and as directed by Engineer in-charge.

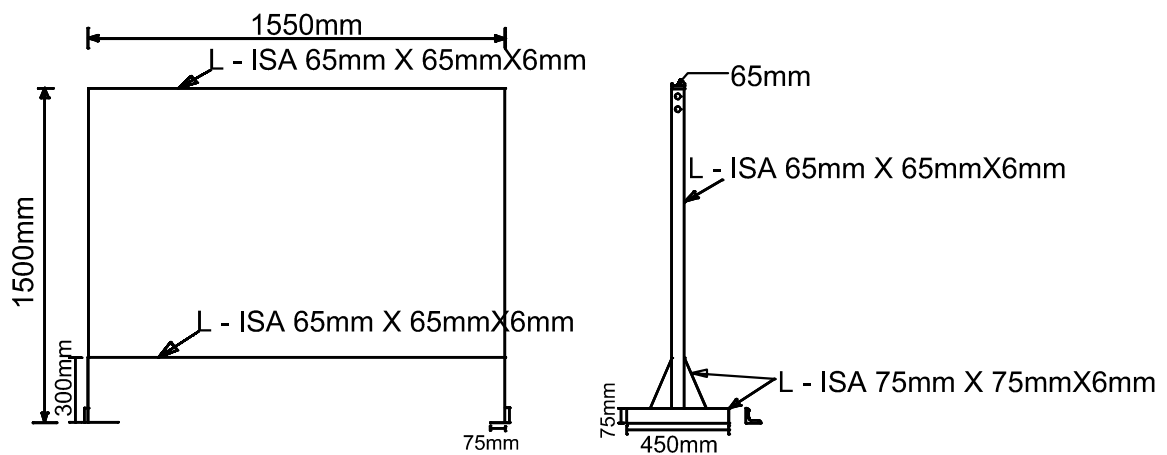

ANNEXURE II

B) Major works:

Providing, fabricating and installing the structural steel barricading made out of 1.5 mm thick M.S. plate of size 2500 mm X 2000 mm, ISMC 250 X 50 channels, M.S. Angles ISA 50 X 50 X 6mm and ISMB 250 as per IS 1161-1 RHS/SHS rolled angle plates of TATA Steel, Lloyd Steel, SAIL, ESSAR steel approved in straight profile of all sizes, shapes and for all works including stiffeners, bolts and nuts, fillet / butt welding, splicing, machine grinding, of all member joints wherever required to give neat appearance, and daily cleaning the barricading along with displaying of the Depthwise slogans as given in Annexure -III etc with interlocking arrangement to avoid gap in between and as directed by Engineer in-charge.

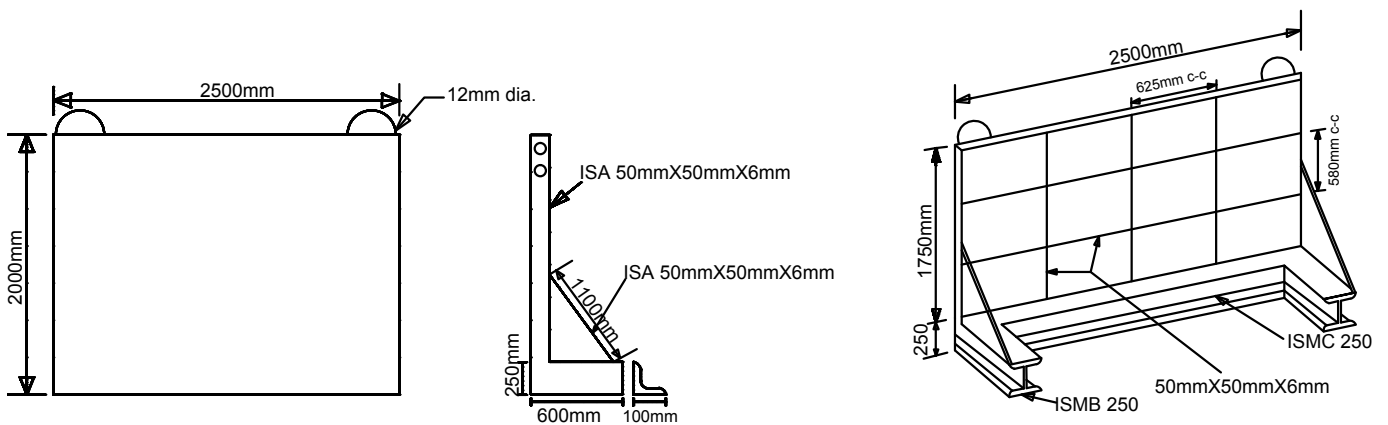

ANNEXURE III

1) HYDRAULIC ENGINEER'S DEPARTMENT/ WATER SUPPLY PROJECTS

- i) Inconvenience regretted
- ii) Ensuring Mumbai's water supply
- iii) Save water Save life

2) ROAD, TRAFFIC / BRIDGES DEPARTMENT

- i) Inconvenience regretted
- ii) Working towards a better tomorrow
- iii) My Mumbai, Green Mumbai

3) SEWERAGE PROJECTS DEPARTMENT/ SEWERAGE OPERATIONS DEPARTMENT

- i) Inconvenience regretted
- ii) Reduce Reuse Recycle
- iii) Clean Mumbai , healthy Mumbai

4) STORM WATER DRAIN DEPARTMENT/ WARD WORKS

- i) Inconvenience regretted
- ii) Working towards a better tomorrow
- iii) Swatch Bharat

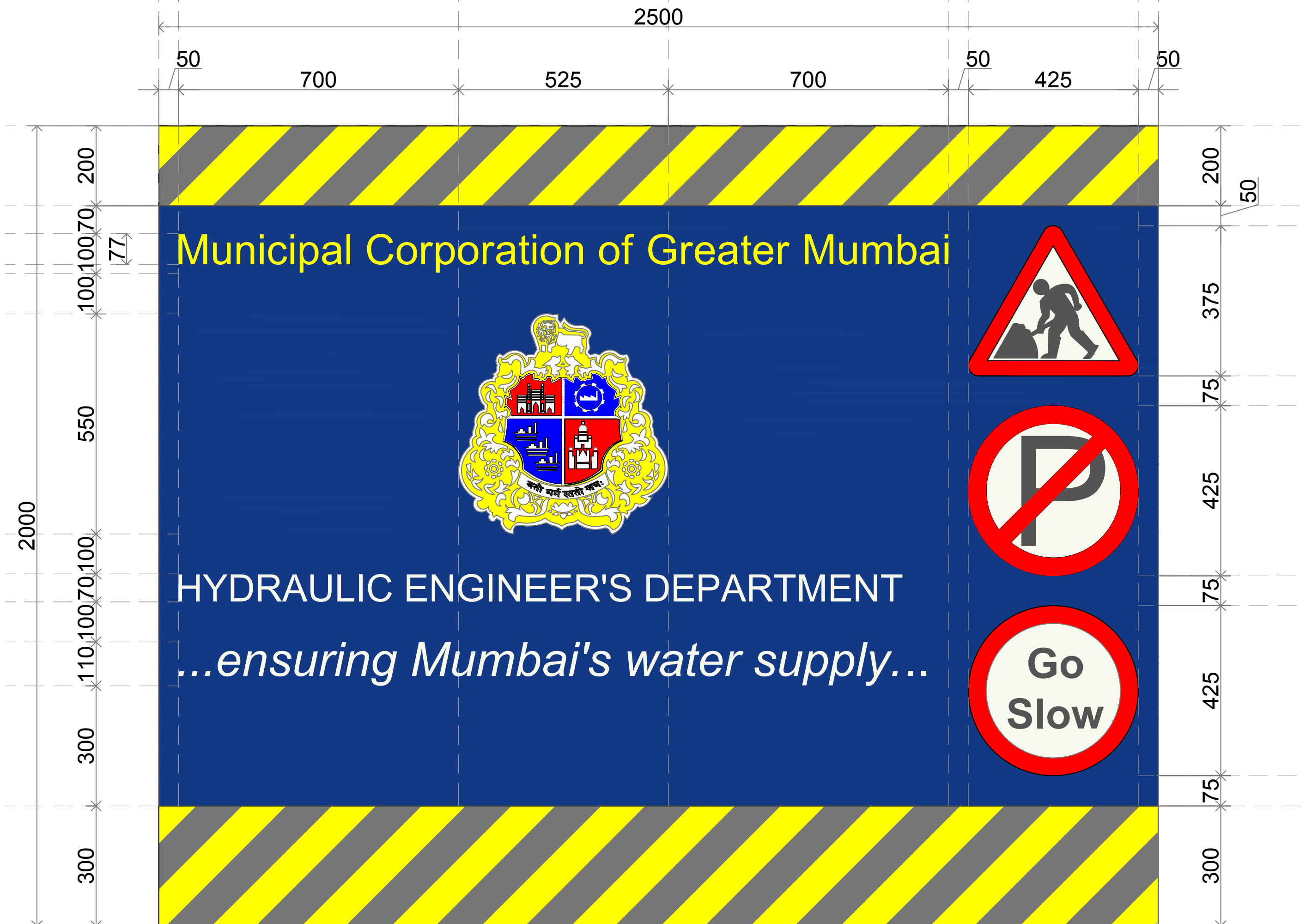

Municipal Corporation of Greater Mumbai

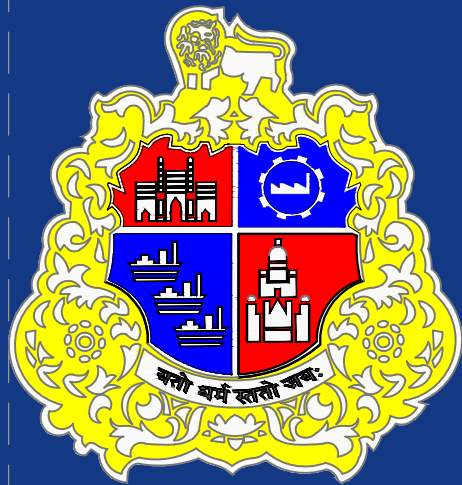

HYDRAULIC ENGINEER'S DEPARTMENT

...ensuring Mumbai's water supply...



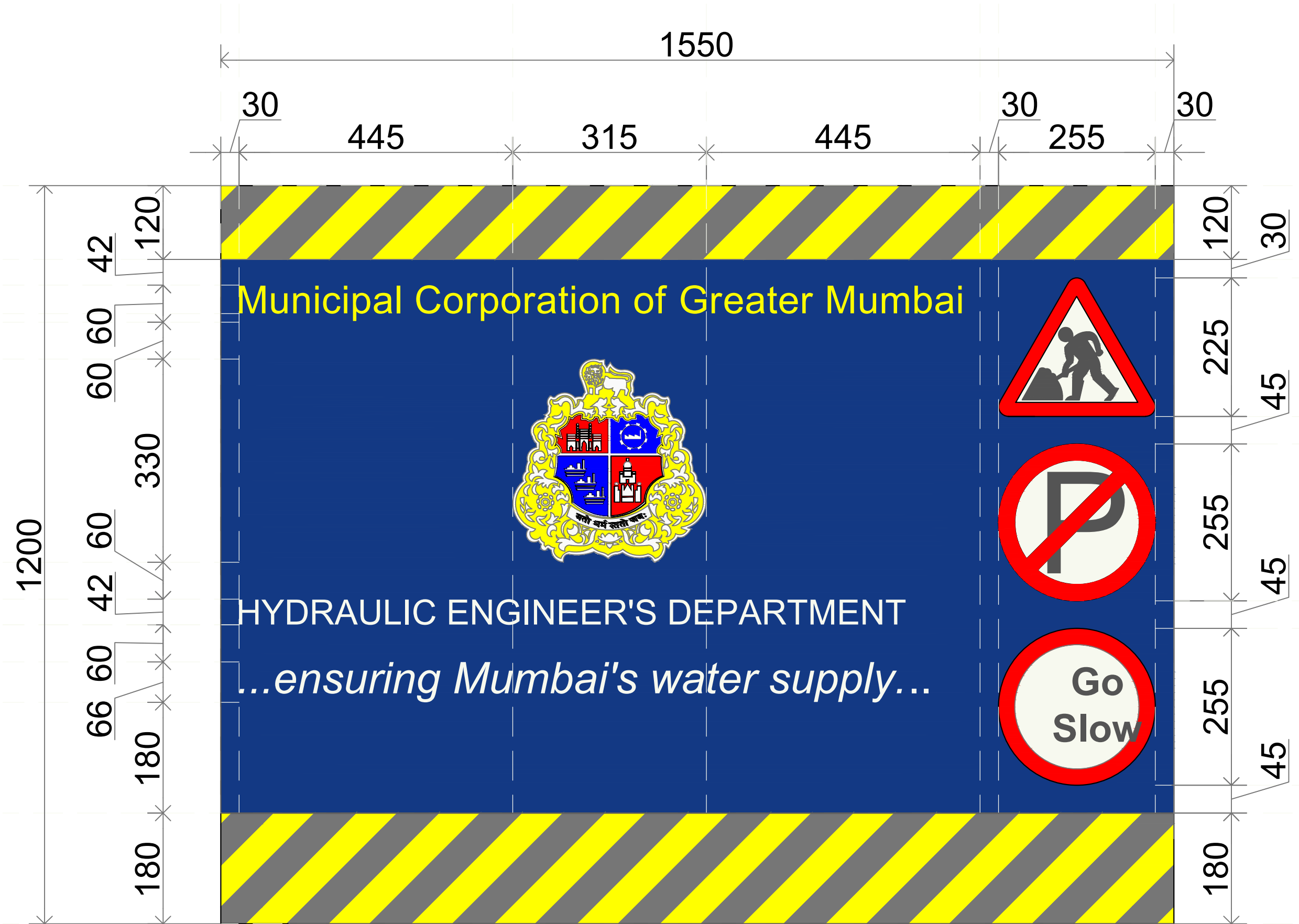



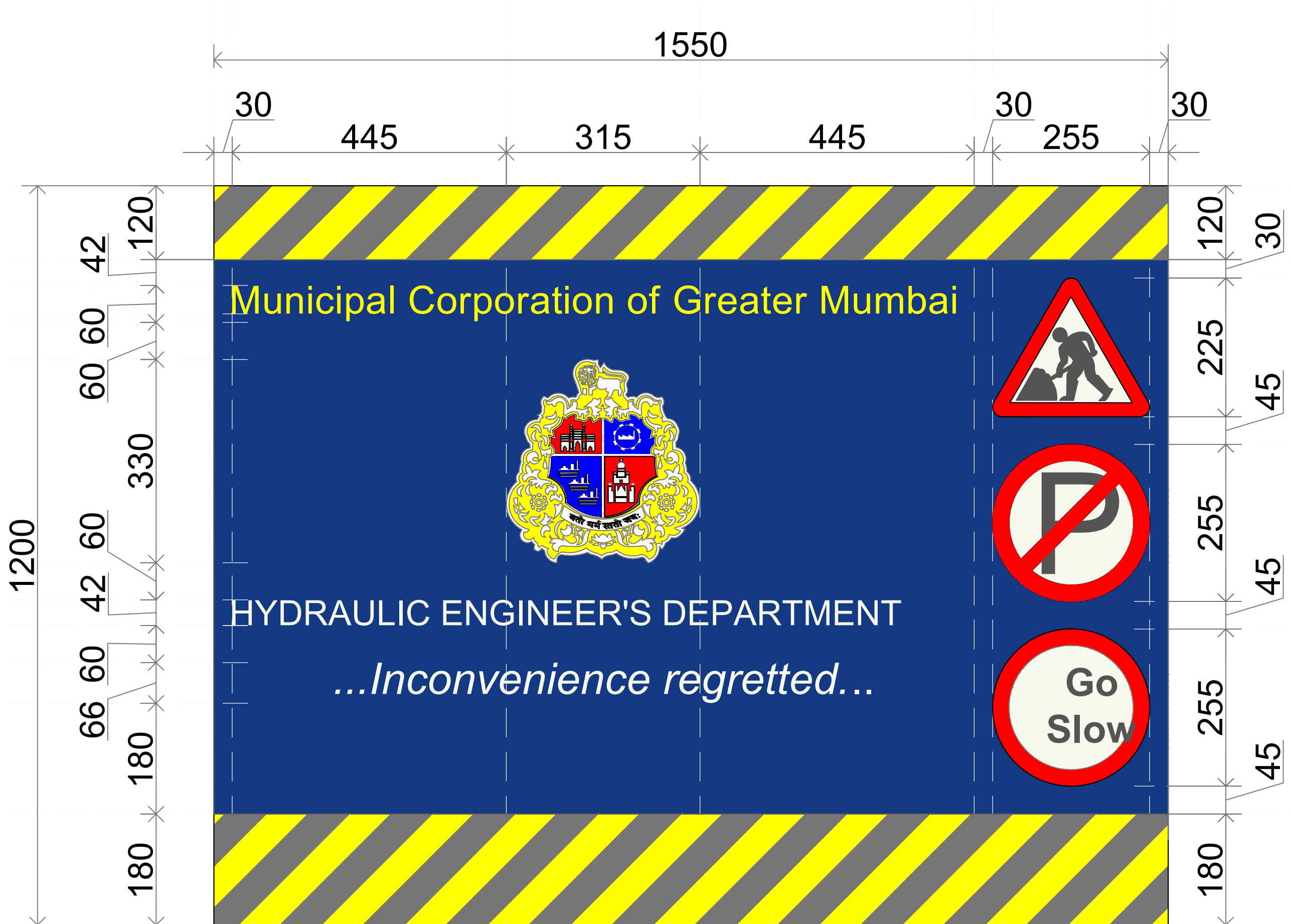

2500

50

700

525

700

50

425

50

200

100

100

550

100

110

300

300

77

Municipal Corporation of Greater Mumbai

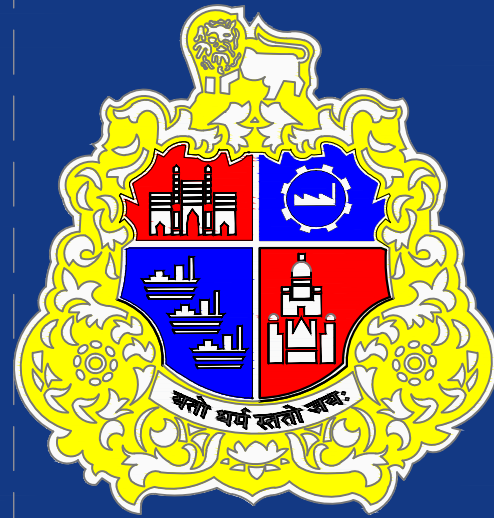

HYDRAULIC ENGINEER'S DEPARTMENT

SAVE WATER

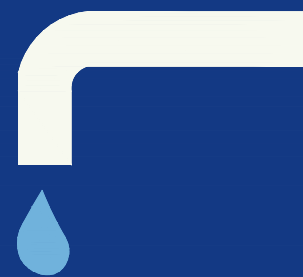

SAVE LIFE

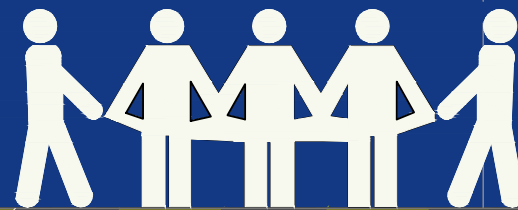

200

50

375

75

425

75

425

75

300

2000

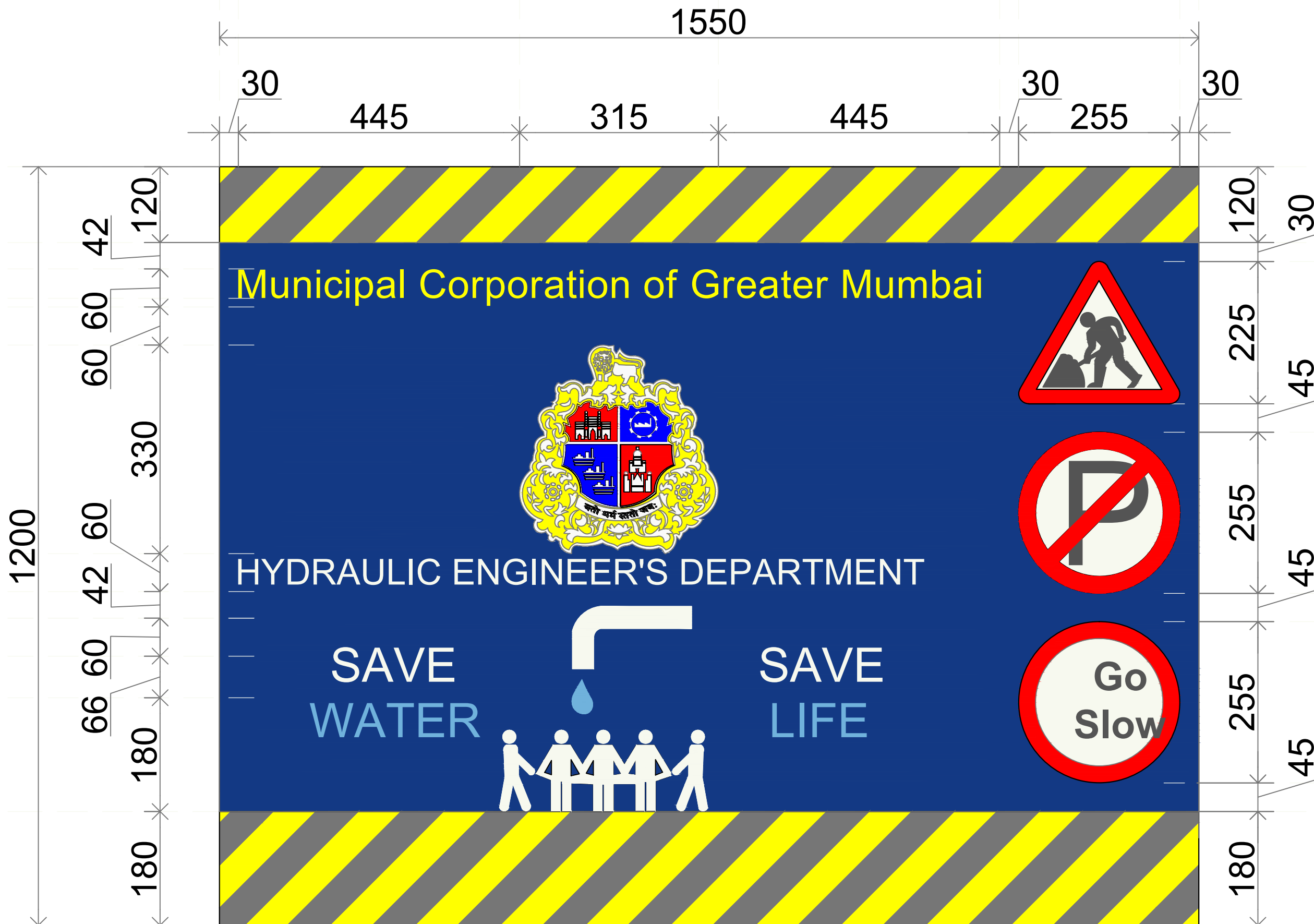

2500

50

700

525

700

50

425

50

200

70

100

100

77

550

100

70

100

110

300

300

200

50

375

75

425

75

425

75

300

Municipal Corporation of Greater Mumbai

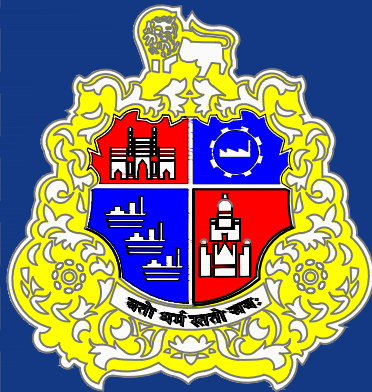

HYDRAULIC ENGINEER'S DEPARTMENT
...ensuring Mumbai's water supply...

Name of Work:

Date of starting:

Date of completion:

Contractors Engineer:

No.

Municipal Engineer:

No.



2000

1550

30

445

315

445

30

255

30

1200

42
120

60
60

60
330

60

60
108

60
180

180



Municipal Corporation of Greater Mumbai

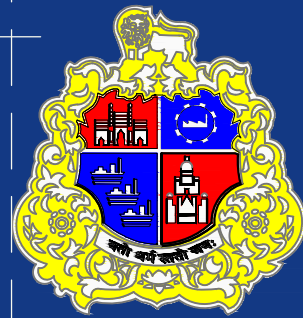

HYDRAULIC ENGINEER'S DEPARTMENT

...ensuring Mumbai's water supply...

Name of Work:
Date of starting:
Date of completion:
Contractors Engineer:
Mob. No.
Municipal Engineer:
Mob. No.



120
30

225
45

255
45

255
45

180





1550

30

445

315

445

30

255

30

1200

42

120

60

60

60

330

60

60

108

60

180

180

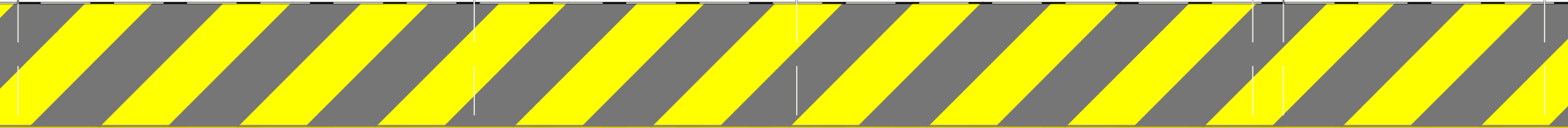

Municipal Corporation of Greater Mumbai



ROAD, TRAFFIC
AND BRIDGE'S DEPARTMENT

...working towards a better tomorrow...



120

30

225

45

255

45

255

45

180





1550

30

445

315

445

30

255

30

1200

42
120

60
60
60

60
330

60

60
108

60
180

180



Municipal Corporation of Greater Mumbai



ROAD, TRAFFIC
AND BRIDGE'S DEPARTMENT
...Inconvenience regretted...



120
30

225
45

255
45

255
45

180







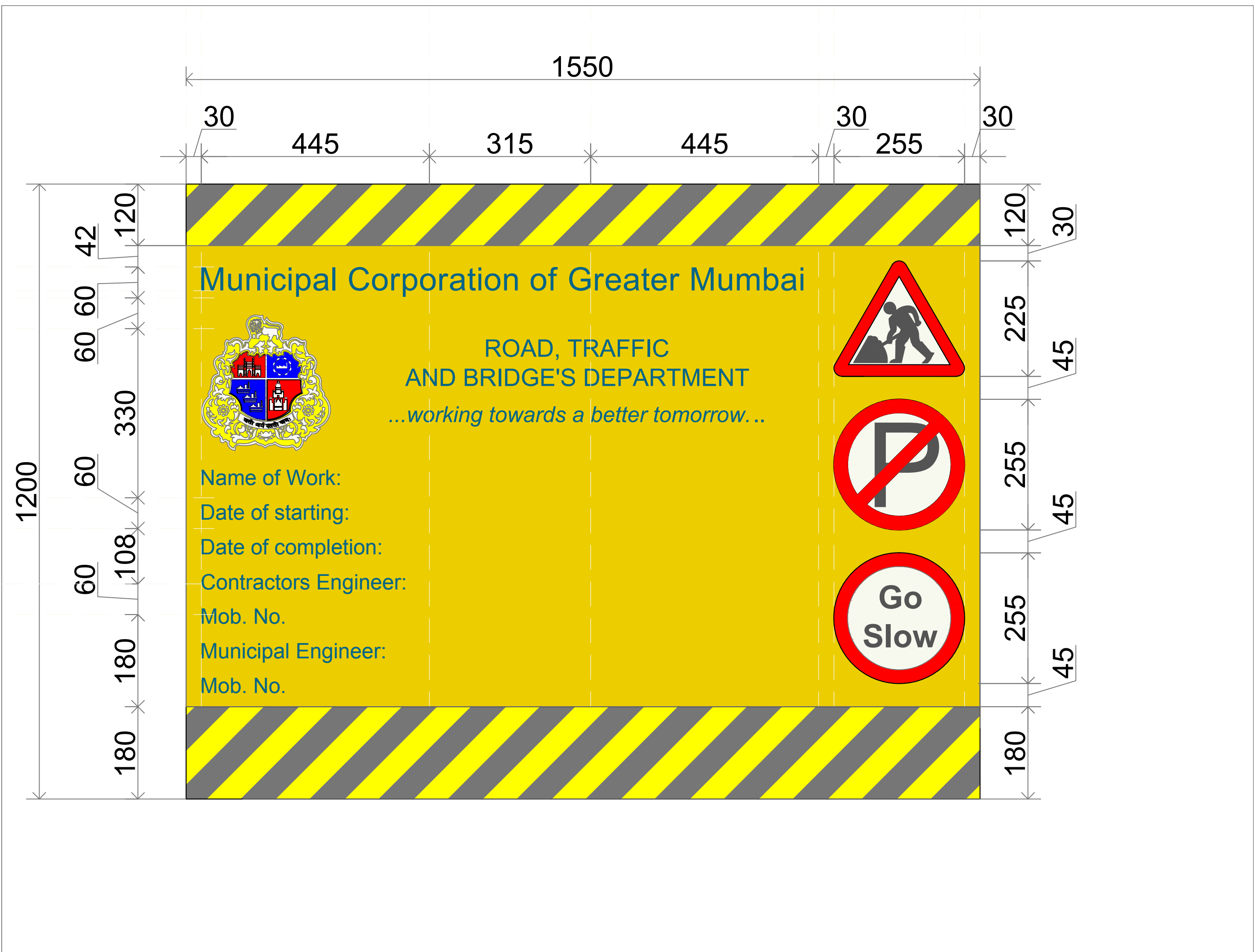



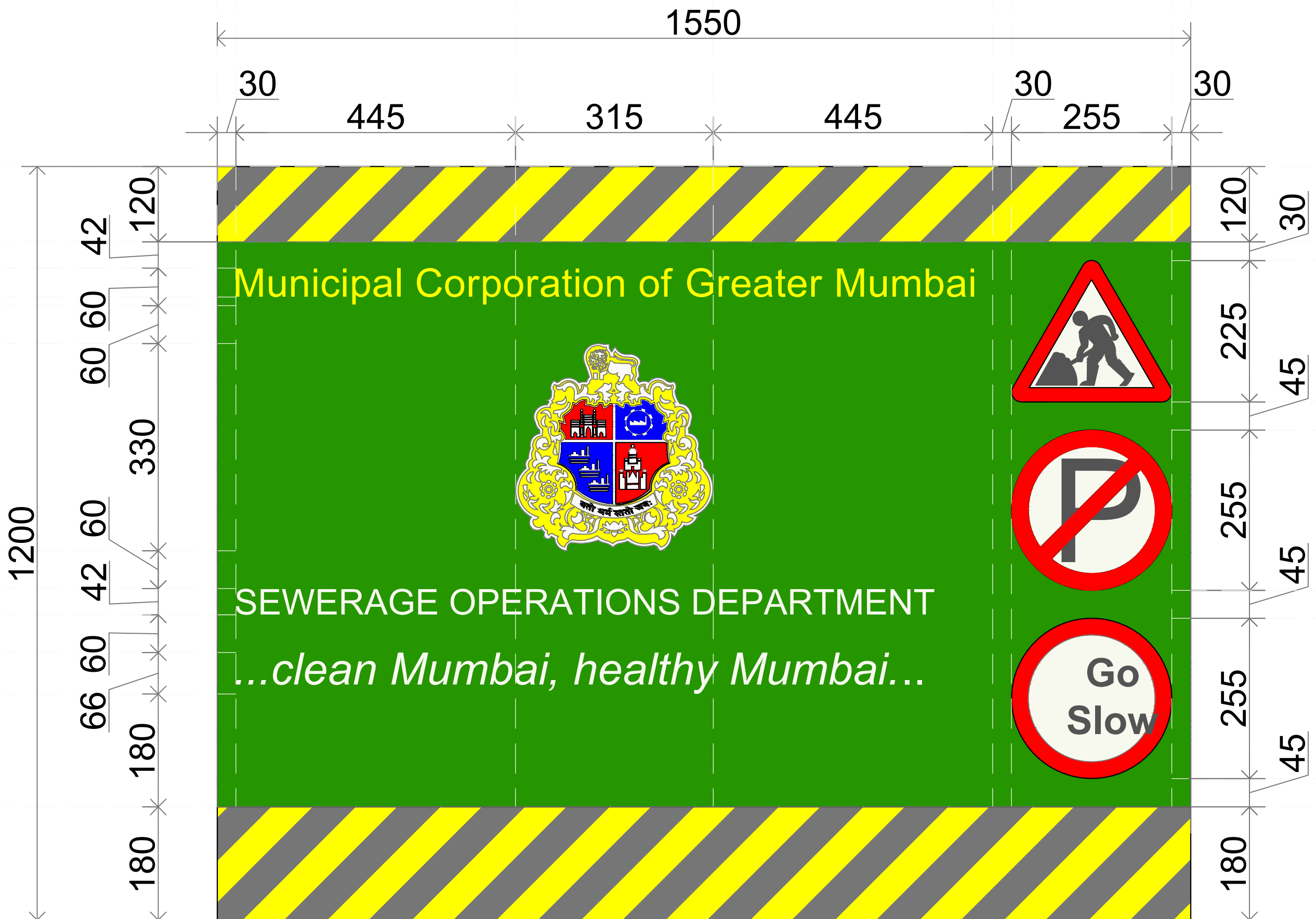



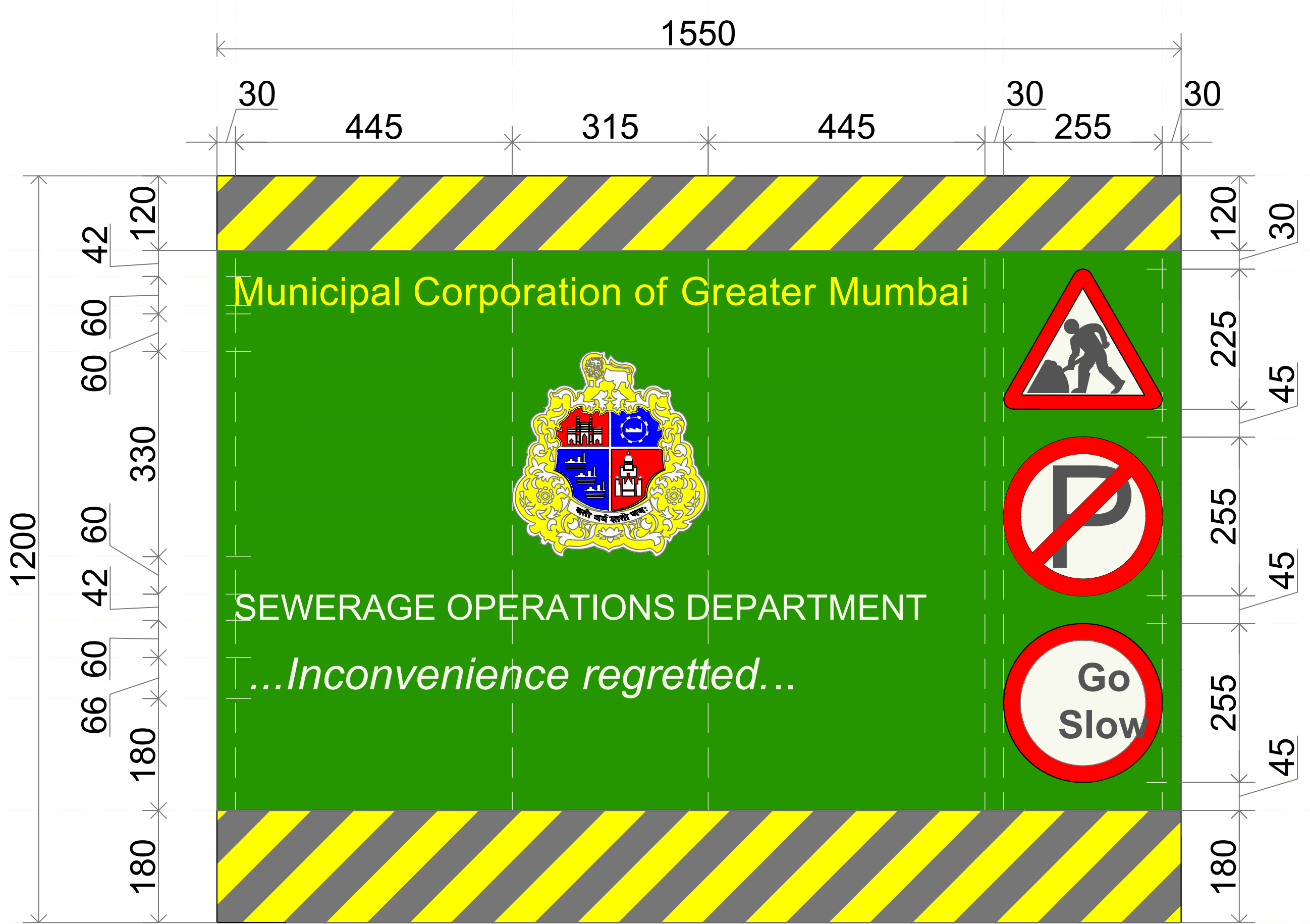



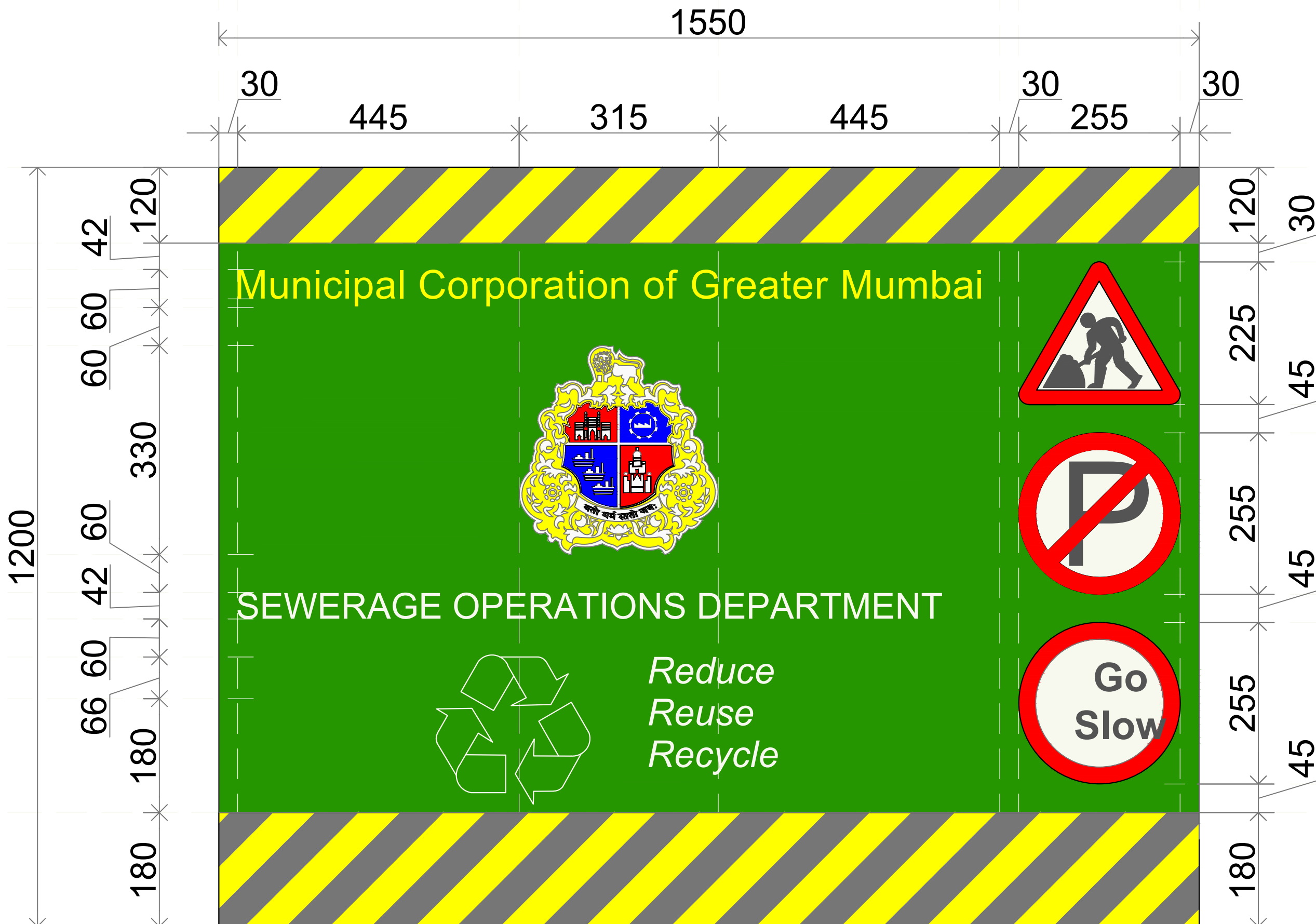







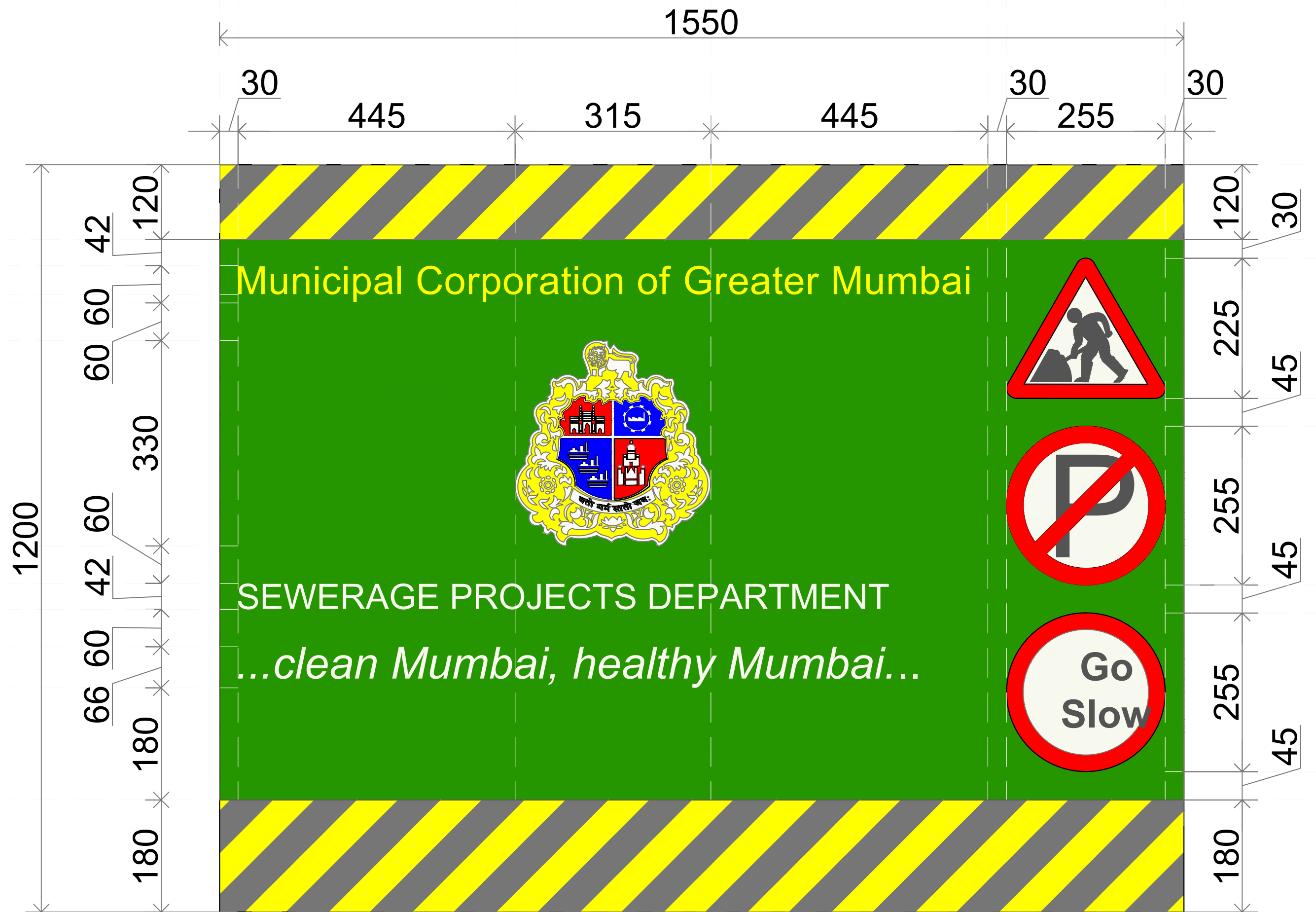



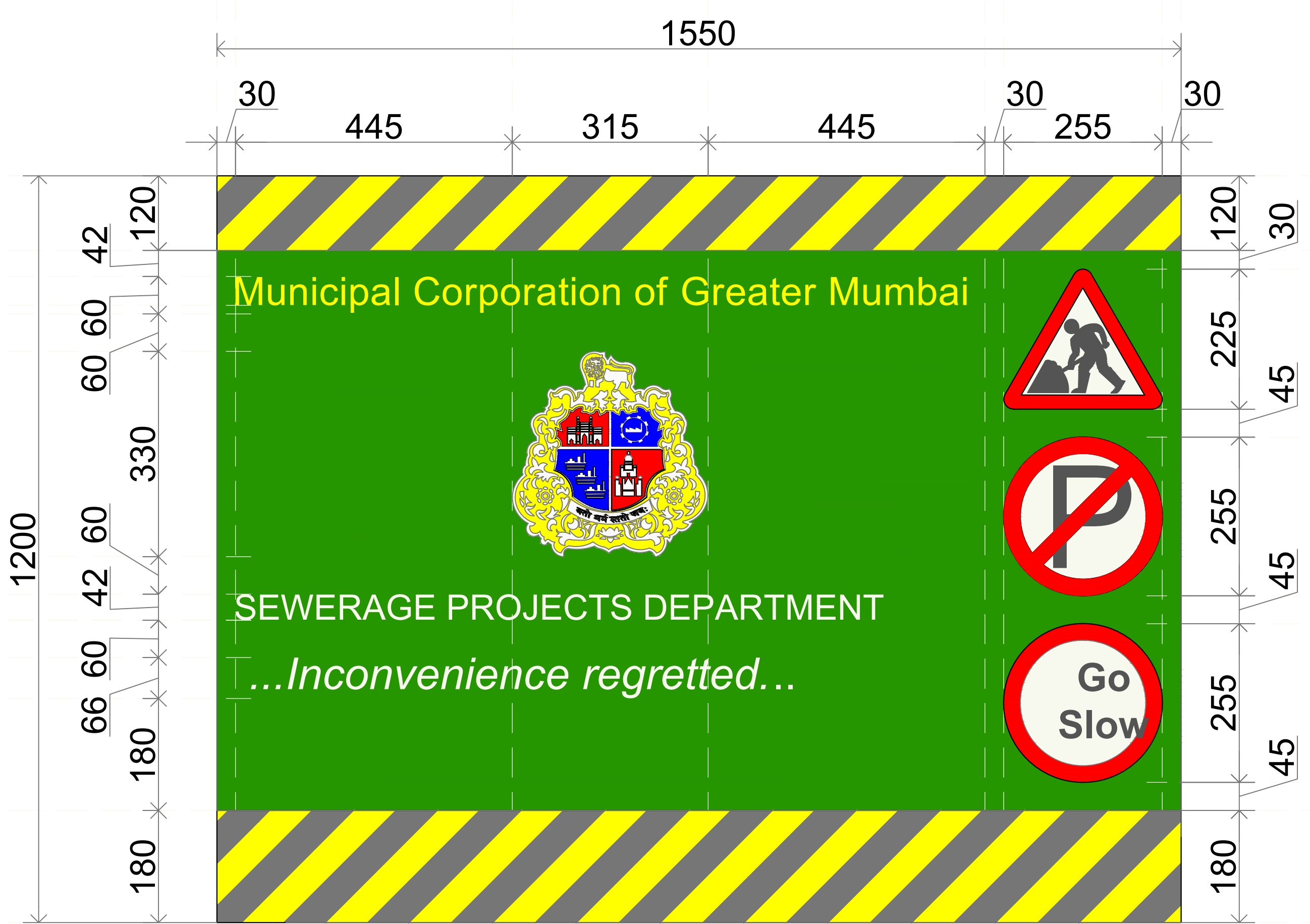



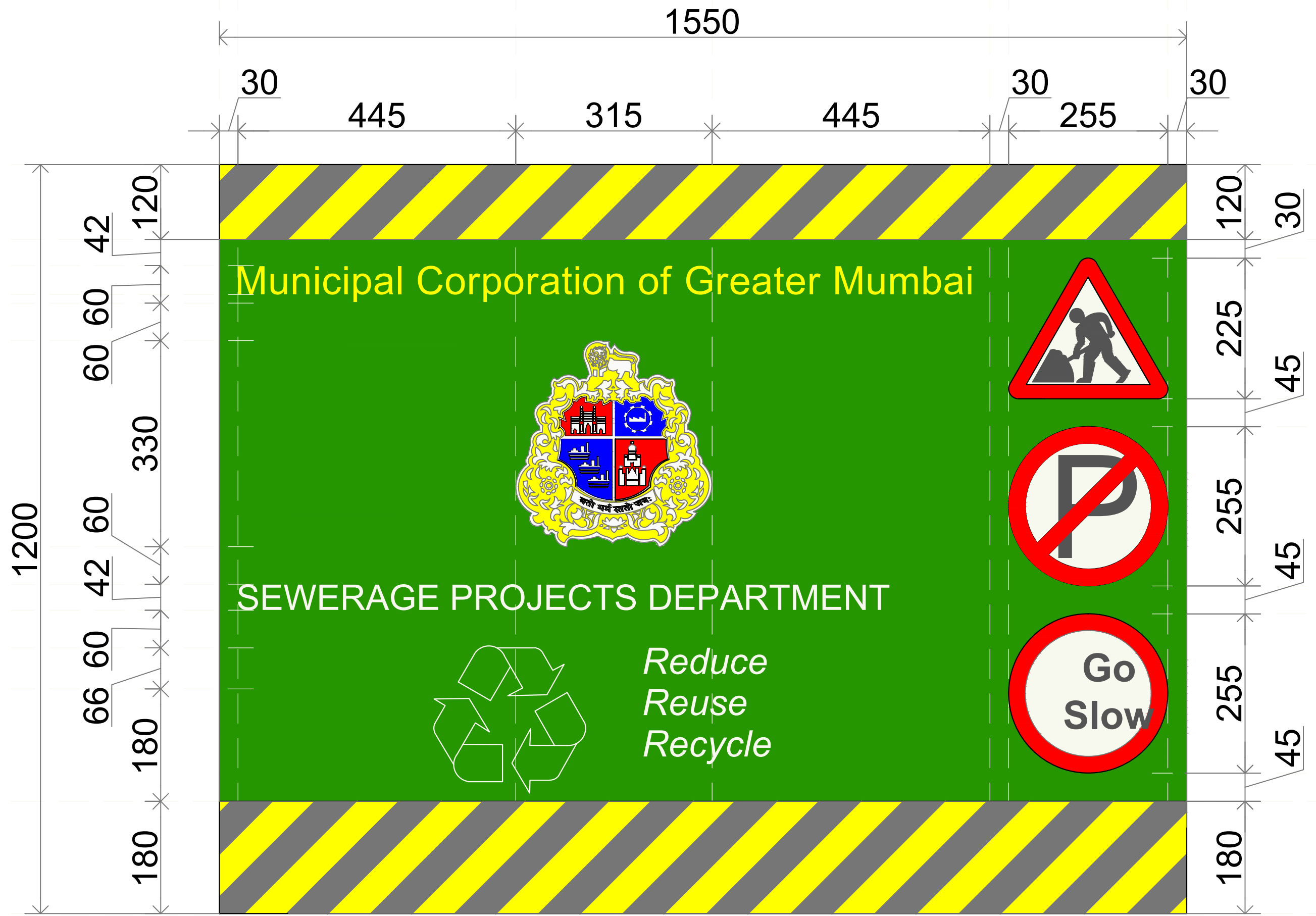



Municipal Corporation of Greater Mumbai



SEWERAGE PROJECTS DEPARTMENT
...working towards a better tomorrow...

Name of Work:

Date of starting:

Date of completion:

Contractors Engineer:

No.

Municipal Engineer:

No.







1550

30

445

315

445

30

255

30

1200

42

120

60

60

60

330

60

42

60

66

180

180

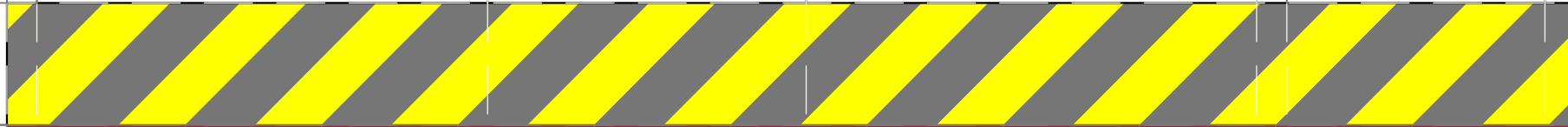

Municipal Corporation of Greater Mumbai



STORMWATER DEPARTMENT

...working towards a better tomorrow...



120

30

225

45

255

45

255

45

180



Municipal Corporation of Greater Mumbai

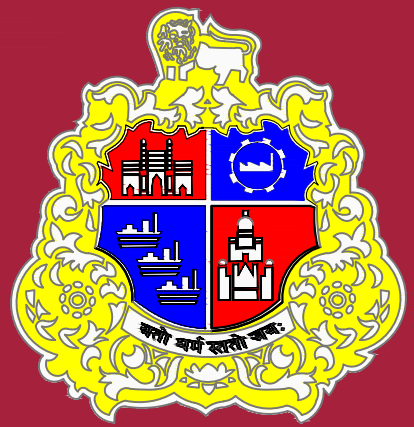

STORMWATER DEPARTMENT

...Inconvenience regretted...

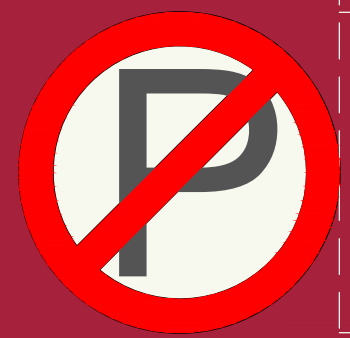

1550

30

445

315

445

30

255

30

1200

42

120

60

60

60

330

60

42

60

66

180

180



Municipal Corporation of Greater Mumbai



STORMWATER DEPARTMENT

...Inconvenience regretted...



120

30

225

45

255

45

255

45

180



Municipal Corporation of Greater Mumbai

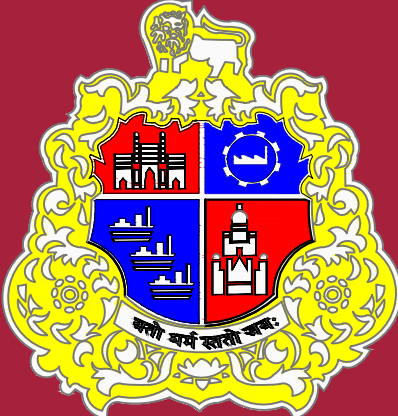

STORMWATER DEPARTMENT



1550

30

445

315

445

30

255

30

1200

42

120

60

60

60

330

60

42

60

60

66

180

180

120

30

225

45

255

45

255

45

180

Municipal Corporation of Greater Mumbai

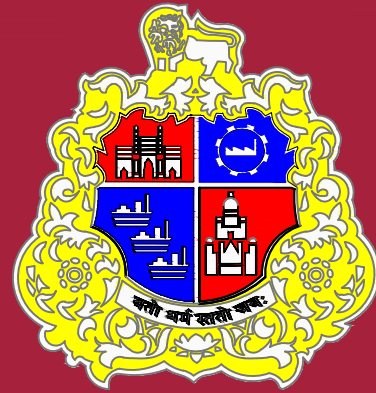

STORMWATER DEPARTMENT



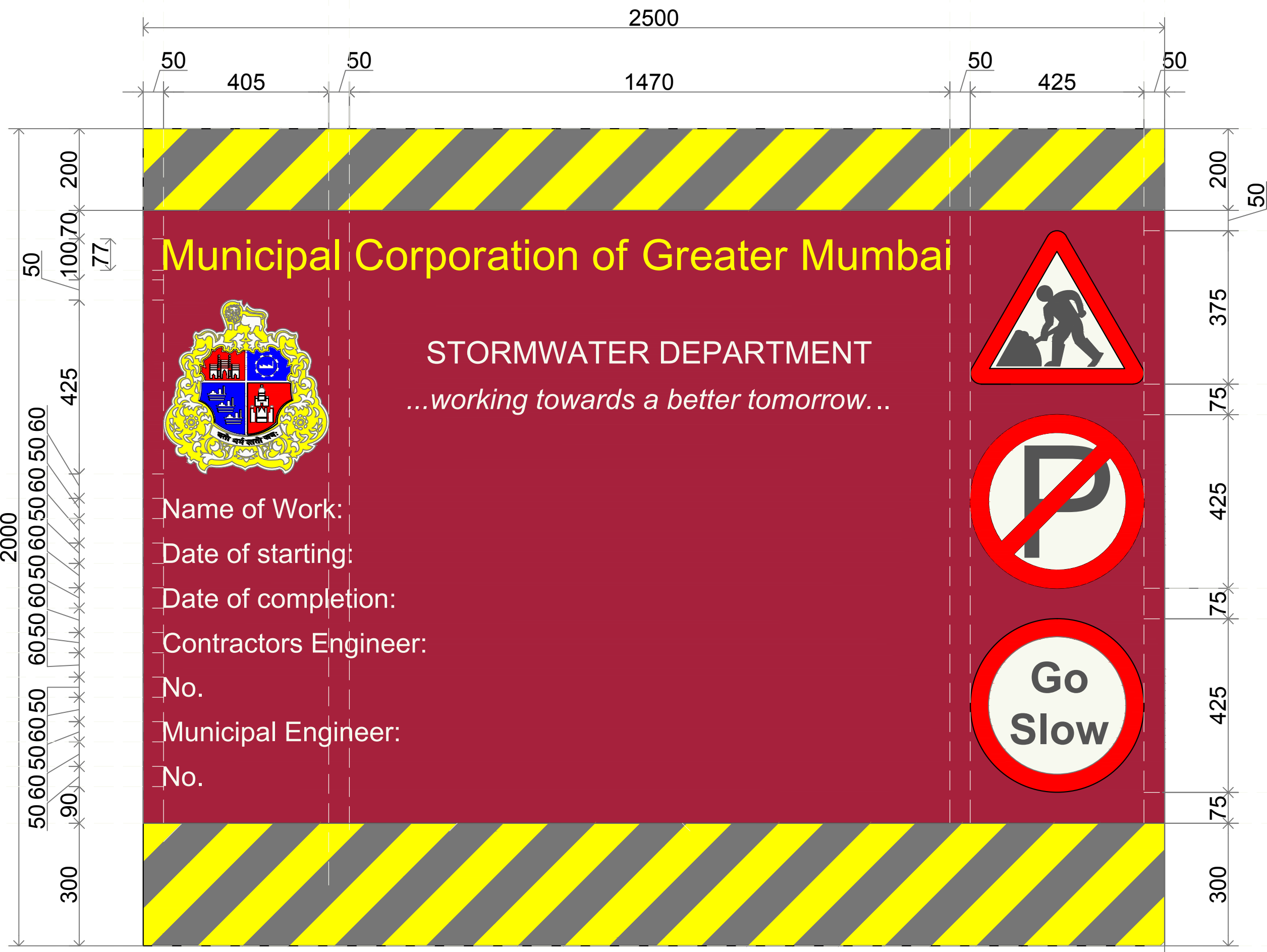

Municipal Corporation of Greater Mumbai

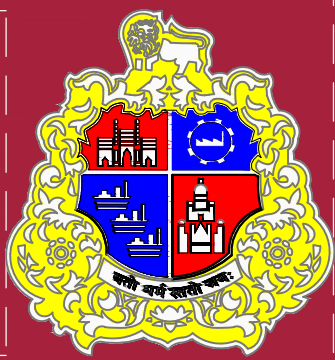

STORMWATER DEPARTMENT
...working towards a better tomorrow...

Name of Work:
 Date of starting:
 Date of completion:
 Contractors Engineer:
 No.
 Municipal Engineer:
 No.





MUNICIPAL CORPORATION OF GREATER MUMBAINo. Dy. Ch. E. / 3591 / Roads / W. S. dated 4.10.2021.

Subject: - W - 375: Improvement of various roads in cement under 63K in R/Central ward of Western Suburbs.

Reference: - 1. Hon. M.C's earlier approval MGC/F/3815 dated 12.02.2021.

2. DL to MS submitted u./no. DyChE/474/Roads/WS dated 03.08.2021.

3. AMC(P)'s note u./no. AMC/P/4772 dated 13.09.2021.

4. Hon'ble M.C's admin approval u./no. MGC/VIP/9612 dated 01.10.2021

- Reference is please requested to Hon'ble M.C's earlier approval under no. MGC/F/3815 dated 12.02.2021 at page N-45 to N-70 in old nasti file – 01 wherein approval was granted to invite the present tender.
- Accordingly, the tender was processed in the month of February-April 2021. Thereafter, DL to MS was submitted u./no. DyChE/474/Roads/WS dated 03.08.2021. for approval of competent authority.
- The lowest bid received for this tender was from M/s Maa Ashish Construction with quoted rebate of 30.15% below the estimated cost.
- The rebates for other tenders were also very low in the range of 21% to 30% below the estimated cost. Hon. AMC(P) vide note u./no. AMC/P/4772 dated 13.09.2021 (@ page N13 to N-14 sought the clarification regarding how quality can be assured when bids are received at such high rebates.
- This department has then submitted its report containing modification to various tender conditions and the said proposal has received the approval of Hon. M.C vide MGC/VIP/9612 dated 01.10.2021.
- Accordingly, the said tender is being reinvited with the said modified conditions as per Hon M.C's approval.

Present Proposal: -**[A] Sanction points from earlier Hon. M.C admin approval MGC/F/3815 dated 12.02.2021 to be continued for said reinvited tender :-**

Kind perusal is requested to Hon. M.C's earlier approval at page N-45 to N-70. In the said approval, sanction is received to following aspects of the project which are proposed to be continued in old nasti file – 01:

1. Para B:- Proposed work, Page N-47to N-47.
2. Para C:- Design and Estimates, Page N- 47to N-48.
3. Para H:- Time Period, Page N-52 to N-52.
4. Para I:- Estimated Cost, Page N-52 to N-52.
5. Para J:- Waiving of DLP, Page N-53 to N-53.
6. Para K:- Use of early strength concrete item R2-RW-10-39, Page N-53 to N-53.
7. Para L:- Not to make applicable circular u./no. DMC/Infra/2137 dated 03.09.2020 and Dy.Ch.E./4017/SWD/WS dtd. 16.08.2019, Page N-53 to N-54.
8. Para M:- Budget Provision, Page N-54 to N-54.
9. Para N:- To accept un-audited balance sheet, Page 54 to N-54.
N-
10. Para P:- Partial waive of condition of CA/F/Project/43 dtd 28.03.2018, PageN-55 to N-55.
11. Para Q:- DLP of various types of road surfaces and its components, Page N-55 to N-56.
12. Para R:- Requirement of technical staff, sufficient labour, Machinery & Material during DLP period and Monsoon period by the contractor Page N-56 to N-57.
13. Para T:- Inclusion of Litigation History under Curable Defects, Page N- 57 to N-57.
14. Para U:- Recovery of necessary taxes, Page N-58 to N-58.

15. Para V:- Price Variation, Page N-58to N-58.
16. Para W:- Instructions of Hon. Minister of Tourism Shri Aditya Thackeray to DMC(Infra) in meeting dated 31.01.2020 held at Mantralaya regarding colour coded footpaths, Page N-5 8 to N-5 8.
17. Para X: - Provision of Utility Duct for laying of various utilities on MCGM roads, Page N-5 9 to N-5 9.
18. Para AA:- To execute 63 k Roads through central agency, Page N-60 to N-60.
19. Para AB:- To include clause regarding CRZ/Forest land/Environment NOC, Page N-60 to N-60
- The said tender is now re invited without any changes in roads to be improved etc. & sanction for above points is already obtained, it is proposed to continue above sanctions of Hon'ble M.C u/ no MGC/F/3815 dated 12.02.2021 for re-invitation of the same tender. Hence, it is proposed to continue the above listed previous sanctions.

In view of the above, ChE(Roads &Tr.)/DMC(Infra)/ Hon. AMC(P)'s sanction is kindly requested for the above please.

[B] Modified stringent tender conditions as per Hon. M.C approval u./no. MGC/VIP/9612 dated 01.10.2021: -

Hon. M.C has granted approval to reinvite this tender along with 30 other tenders with modified stringent tender conditions.

The modified tender criteria may be summarized as below: -

- (a) The tender is now invited under Original & new category of tenders of SBD.
- (b) similar work experience is insisted as: - *"The bidders should have carried out Road carriage way or Major vehicular bridges in CC pavement / CC Passage / TWT/UTWT in M40 and above or Asphalt Road in Asphalt mix/Mastic asphalt".*

- (c) Ownership of minimum machineries shall be insisted for the contractual agencies with proper documentary evidence (i.e. in the name of agency).
- (d) To fix responsibility on plant owners, joint Registered Irrevocable Undertaking (U/T) cum Declaration cum Indemnity bond from bidder and plan owner is insisted regarding supply of materials as per MCGM specification.
- (e) Condition that QMA staff and MCGM staff will be deployed on plant for checking of their functioning & materials used for manufacturing and for quality management purposes is included.
- (f) ASD at the time of bidding is modified as under: -

Sr. No.	Rebate quoted by contractor	ASD applicable
1	Up to 12% rebate	No ASD
2	12.01% to 20% rebate	1% of Estimated Cost for each percentage and part thereof above 12% rebate
3	20.01% rebate and above	8% of Estimated Cost + (2% extra for each percentage and part thereof over and above 20% rebate)

- (g) Performance Guarantee will be insisted as per SBD in the form of Demand Draft (**D.D.**) only.
- (h) Contract deposit, ASD and any other deposits, Performance Guarantee (**P.G.**), will neither be accepted in Bank Guarantee (**B.G.**) nor will be released against **B.G.**
- (i) All deposit will have to be deposited in the form of Demand Draft (**D.D.**).
- (j) Payment of bill will be under 80:20 deferred payment scheme with certain modifications, i.e 80% amount of the certified bill will be released immediately, 20% amount will kept in deposit and released in phases.

- (k) Since, 80:20 deferred payment scheme is implemented, retention money will not be deducted from the running bill.
- (l) The 20% deferred payment shall not be released against Bank guarantee (B.G) at any stage of contract.
- (m) **Penalty equivalent to cost of defective work or Rs. 10,000/- (whichever is higher)**, per day/lapse/site workspace, in accordance to the gravity of default communicated in writing.
- (n) The circulars pertaining to various concessions granted shall not be applicable to the road tenders henceforth. The list of such circulars is as under :-

Sr. No.	Circular No.	Circular related to
1	Circular CAF_Project_21 dated 07.09.2020	revised RM, contract deposit, PG & ASD guidelines
2	CA(F)/Project/32 of 26.10.2020	Bid Security or EMD
3	CA(F)/Project/36 dtd 07.12.2020	Revised RM, Not to insist PG
4	CA(F)/Project/41 of 09.02.2021	Performance Guarantee (P.G)
5	CA(F)/Project/42 of 09.02.2021	Additional Security Deposit (A.S.D)

- (o) Maximum two (2) shortfalls will be allowed for curable defects. For more than two (2) nos. of shortfalls, 2% EMD will be forfeited for each shortfall thereafter.
- (p) In case of non-curable defects, the same will not be communicated and the bid will be made non-responsive and their 10% E.M.D. will be forfeited.
- (q) Only original document scans shall be uploaded, and they may be cross-checked against original during scrutiny.
- (r) Rate analysis of items amounting to 90% of estimated cost will be requested for those bids who quote premium/rebate more than or equal to 15%.
- (s) The engineering staff of contractor shall be insisted from reputed institutes only.

- (t) Material testing will be allowed in ratio:- 80% tests at Municipal testing lab and remaining 20% tests will be allowed only at reputed govt. labs likely IIT/VJTI/SPCE/MSME/National Test House (W.R.)/ Govt. Lab only.
- (u) The testing at MCGM's registered private labs will be strictly allowed only on the directions/approval of the concerned Dy.Ch. Engineer.
- (v) Condition that Vigilance department will carry out compulsory monthly frequent visits to RMC/Asphalt/Mastic plants/Batch mix plant, Material sources and road sites is included in the draft tender.

In view of above, Ch.E(Roads &Tr.)/DMC(Infra)/ Hon. AMC(P)'s approval is requested to invite the short notice tender with the modified stringent tender conditions as approved by Hon. M.C vide MGC/VIP/9612 dated 01.10.2021.

[C] To accept un-audited balance sheet: -

It is to mention here that, most of bidders, due to Covid-19 epidemic will not have audited balance sheet for preceding two financial years i.e. 2019-20, 2020-21. In such cases, un-audited balance sheets of financial year 2019-20, 2020-21 duly certified by Chartered Accountant shall be accepted.

Hence, Hon. AMC(P)'s approval is requested for accepting unaudited balance sheets for financial years 2020-21 and 2019-20.

[D] 80:20 Deferred payment scheme for trenches: -

80:20 Deferred payment scheme is made applicable to the present tender work. It is essential that trenches taken on this work should also be reinstated with the same diligence, quality assurance and accountability. Hence, it is proposed that the payment for reinstatement of trenches should also be done under 80:20 deferred payment scheme i.e. 80 % on completion of reinstatement of trench work.

20 % as per deferred payment schedule

a. For C.C Roads with 10 years DLP:-

20% withheld amount will be released as under: -

- (i) For trenches taken prior to completion of 8th year of DLP, 4% will be released each year from the completion of 6th year of the DLP till the completion of DLP.

OR

- (ii) In case trench is taken after completion of 8th year of DLP or later then in two equal yearly instalments of 10% each after the year in which the reinstatement is completed.

b. For C.C Passage /Roads & Junctions in Mastic and other roads with 5 years DLP

20% withheld amount will be released as under: -

- (i) For trenches taken prior to completion of 3rd year of DLP, 6% will be released each year after the completion of 3rd and 4th year of the DLP and then 8% will be released on completion of the 5th year.

OR

- (ii) In case trench is taken after completion of 3rd year of DLP or later then in two equal yearly instalments of 10% each after the year in which the reinstatement is completed.

c. For Roads in Asphalt mix and other roads with 3 years DLP

20% withheld amount will be released as under: -

- (i) For trenches taken prior to completion of 1st year of DLP, 10% will be released each year after the completion of 2nd and 3rd year of the DLP.

OR

- (ii) In case trench is taken after completion of 2nd year of DLP or later then in two equal yearly instalments of 10% each after the year in which the reinstatement is completed.

[E] Financial Capacity: -

As per SBD, the financial capacity of the bidder shall be as follows:-

“Achieved an average annual financial turnover as certified by ‘Chartered Accountant’ (in all classes of civil engineering construction works only) equal to 30% of the estimated cost of work in last three (3) financial years immediately preceding the Financial Year in which bids are invited.

- To ascertain this, tenderer(s) shall furnish /upload the financial statement (Audited balance sheet) duly certified by Chartered Accountant.
- The turnover can be enhanced by 10% every year to bring the present level.”

In regards to the Financial capacity, proforma-II needs to be submitted by bidder. (page C-_____). Now as per Proforma-II, the average annual financial turnover shall be considered during last 5 financial years instead of 3 financial years is mentioned in eligibility criteria condition.

In view of this discrepancy and to have healthy and broader competition, approval of Hon. AMC(P) is necessary. Similar approval for regular and routine category of works is obtained for work code E263 u./no. MGC/F/1422 dated 24.01.2020, (copy @ page C-203 to C-227).

In view of the above, Hon. AMC(P)'s approval is requested to consider average financial turnover at 30% of the estimated cost of work in **last five(5) financial years instead of three (3) financial years for works in Original and new category as per SBD.**

[F] Not to deduct Retention Money: -

As 80:20 deferred payment scheme is being implemented it is proposed not to deduct retention money from the running bills as sufficient monetary security is available.

In view of the above, Hon. AMC(P)'s approval is requested not to deduct Retention money.

[G] To invite short notice tender with period of 15 days and pre-bid on 3rd day:-

- There has been pendency of road tenders since last two years due to various reasons. It is utmost necessary that the road works being tendered now should be commenced prior to onset of Model code of conduct for municipal elections.
- The entire tendering process from estimation to opening of Packet-C usually takes

60 days. In the present case, the estimation is already done.

- The tender files have already been scrutinized once by the various superior authorities at the time of last tender invitation in the month of February-April 2021.
- It is not possible to complete the tender process with normal duration and commence the work prior to onset of model code of conduct.
- Hence, it is proposed to reinvoke these stage-I tenders with short notice of 15 days. As the tender procedure time is reduced it is also proposed to hold the Pre-bid after three (3) days of date of start of sale instead of the usual seven (7) days.

In view of the above, Hon. AMC(P)'s approval is requested to invite the tenders as short notice tenders with period of 15 days and pre-bid after three days of start of sale of tender.

In view of above, instant tender W-375 being an Original and New work:

A. Approval of Ch.E. (Roads & Tr.) is requested for following;

- i. To meet the charges of advertisement bill from the following budget.

Fund Code	:	11
Cost Centre Code	:	1000150000
Function Code	:	00204000000
G.L.Code	:	220600000
Name of function	:	Advertisement & Publishing.
- ii. To accept the E.M.D. at 1% of Estimated Cost amounting to Rs. 13,48,000/- through online mode.
- iii. To the Tender Notice as at page C-185 to C-186.
- iv. To create / generate separate WBS Elements / Purchase Orders for road wise works.

B. Approval of D.M.C. (Infrastructure) is requested for following:

- v. To technical sanction at page C- 181 having estimated cost of Rs. 13,47,95,692/- and total project cost amounting to Rs. 18,04,64,473/- including usual percentages.

C. Approval of Hon'ble A.M.C. (P.) is requested for following:

- vi. To administrative approval for draft tender having estimated cost of Rs. 13,47,95,692/- and total project cost amounting to Rs. 18,04,64,473/- including usual percentages.
- vii. To the accompanied draft tender with modifications as mentioned in Para "B" at page N-17 to N-20 having the estimated cost of Rs. 18,04,64,473/-.
- viii. To accept un-audited balance sheet for the financial year 2020-21 and 2019- 20 duly certified by Chartered Accountant as elaborated in Para "C" at page N-20.
- ix. To make payment of reinstatement of trenches as per prevailing trench policy with 80:20 deferred payment ratio as elaborated at Para "D" at page N-20 to N-21.
- x. To continue the approval to sanction points from earlier admin approval MGC/F/3822 dated 12.02.2021 as elaborated at para-A at page N-16 to N-17 in present proposal.
- xi. To invite short notice tender of 15 days with Modified stringent tender conditions as per Hon. M.C approval u./no. MGC/VIP/9612 dated 01.10.2021 as elaborated in Para "B" at page N-17 to N-20 of present proposal.

- xii. To consider average financial turnover at 30% of the estimated cost of work in last five (5) financial years instead of three (3) financial years for works in Original and new category as per SBD as elaborated in Para "E" at page N-21 to N-22.
- xiii. Not to deduct retention money as elaborated in Para "F" at page N-22.
- xiv. To invite the tenders as short notice tenders with period of 15 days and pre-bid after three days of start of sale of tender as elaborated in Para "G" at page N-22 to N-23.

On receipt of approval, PRO shall be informed to publish the tender notice in local newspapers as per prevailing practice.

Submitted for approval of (A), (B) & (C) please.

Acc in FB:

- 1 Nasti file in File board
2. Copy of D.T in file board.
(separate nasti)

Manoj M. Kamdar
(Manoj M. Kamdar)
Dy.Ch.E. (Roads) W. S.

Ch. Eng. (Rds. & Tr.)

Sunil Baviskar
(Sunil Baviskar)
Ex. Eng.(Roads),Z-VII

Sr. No. (A) (i to iv) & Sr. No. (B) (v) at page N-23 to N-23 is approved by me. File is submitted for further approvals to (C) (vi to xiv) at pages N-24 to N-24.

Hon. AMC(P)

Sir,

Floral Under

10/10/21
A. M. C. (P)

Rajendra Talkar
(Rajendra Talkar)

**Ch. Eng. (Rds. & Tr.) &
DMC (Infra)**

बृहन्मुंबई महानगरपालिका
प्रमुख अभियंता (रस्ते वाहतूक)
यांचे कार्यालय
- 4 OCT 2021
क्र.प्र.अ.(रस्ते)/ 3899 (NF+1NF+1DT)

4 OCT 2021

बृहन्मुंबई महानगरपालिका
उप आयुक्त (पायाभूत सुविधा)
यांचे कार्यालय
- 5 OCT 2021
क्र.उप.आ./पा.स./ 3511

2NF+1DT in FB

बृहन्मुंबई महानगर पालिका
अतिरिक्त आयुक्त (प्रकल्प)
यांचे कार्यालय
04 OCT 2021
क. अति.उ.अ./प्रकल्प/ 4198

04/10/2021

Ch.E (Roads & Traffic)

बृहन्मुंबई महानगरपालिका
प्रमुख अभियंता (रस्ते वाहतूक)
यांचे कार्यालय
- 2 DEC 2021
5315 (2NF
+ 3DT in FB)
क्र.प्र.अ.(रस्ते)